

HP PRU100 TYPE STAINLESS STEEL PRESSURE REDUCING VALVE

CHARACTERISTICS

The PRU100 stainless steel pressure reducer is dedicated to the pressure relief of gases and high pressure liquids. The upstream pressure is adjusted with the thumbwheel. Vespel® tightness and 316 stainless steel construction. The PRU100 has a CV flow coefficient of 0.06. NPT threaded connection. Pressure reducing valve delivered with 2 1/4" NPT connected manometers.

AVAILABLE ITEMS

1/4" NPT threaded connections
CV flow coefficient: 0.06
Adjustment range:

- 70-3400 mbar (1-50 psi)
- 0.2-17 bar (3-250 psi)
- 0.35-34 bar (5-500 psi)

LIMITS OF USE

Max. allowable pressure (PS)	240 bar (3500 psi)
Allowable temperature (TS)	40 °C / +175 °C

CONSTRUCTION

Item	Material
Body	Stainless steel AISI 316
Diaphragm	Stainless steel AISI 316L
Seat	Vespel ^(R)
Thumbwheel	Plastic

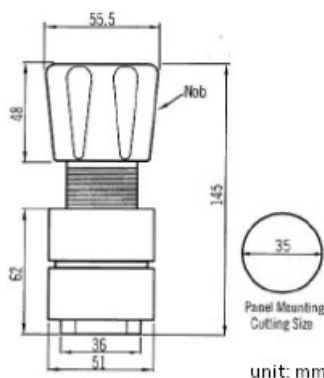
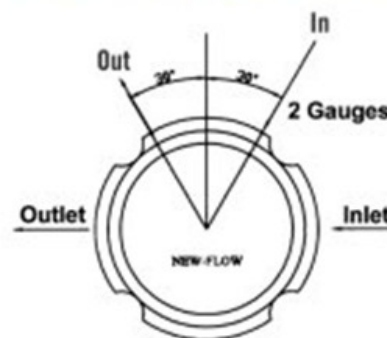

MOUNTING

Please check if the pressure range indicated on the body matches the working conditions requirements. Please shut off the up and downstream valves, depressurize the piping and lower the installation temperature to room temperature before any mounting/service. Install a filter upstream and a control valve upstream and downstream. Carefully remove any particle remaining on the piping by clearing with water or blowing with compressed air. Install the pressure reducer following the direction of the arrow on the body. Open the up and downstream valves. To adjust the downstream pressure, please use the adjusting thumbwheel.

Technical data given for information purpose only. May be subject to alteration without prior notice