

# Sight Glass Discs for Aseptic Screwed Pipe type 83 Connection DIN 11864-1

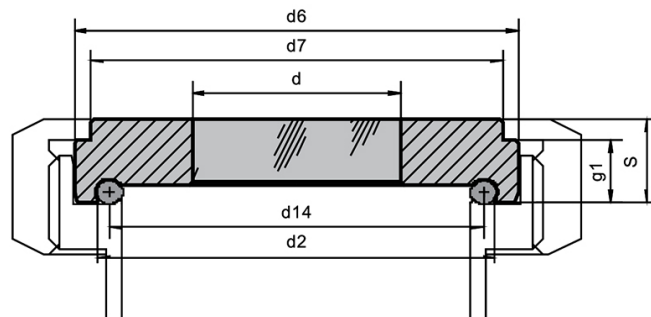
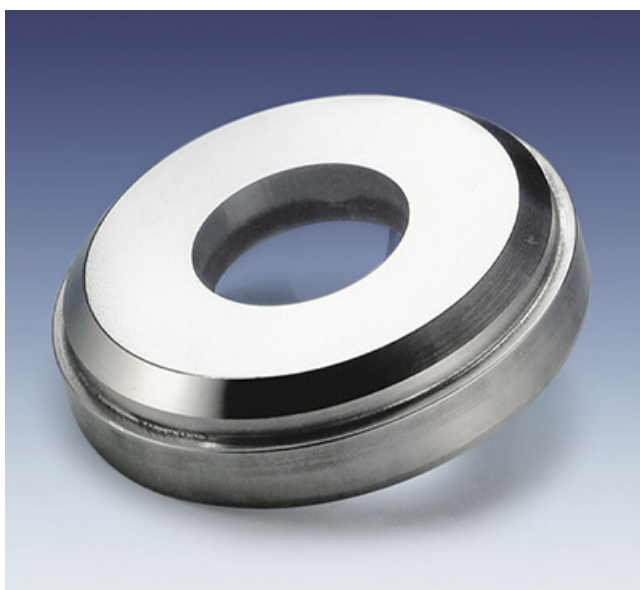

## Applications:

- Aseptic screwed pipe connection DIN 11864-1

## Advantages:

- Security against total failure
- Easy cleaning – gap can be checked
- Flush glass/metal joint to atmospheric side
- Suitable for CIP and SIP cleaning
- Maximum visual aperture
- We can supply with light fittings BKVLR A 24 V, AC/DC, 20 W or 50 W, mat. DIN 1.4301

## Operating conditions:

- Pressure: max. 25 bar
- Temperature: see table

Ring materials	Operating temperature
1.4462	-30 °C to +280 °C
2.4602	-60 °C to +300 °C
2.4605	-60 °C to +300 °C
2.4610	-60 °C to +300 °C

## Technical data:

Manufactured and tested to:

- Directive for pressure equipment 2014/68/EU, Module H (DIN/EN/ISO 9001)
- AD2000 Standards W0/TRD 100
- Sight glass fused to metal conforming to DIN 7079
- Materials to VdTÜV specifications and the DIN/EN designated standards

## Material certificates:

- Certificate of Conformity EN 10204 – 3.1 or 3.2 for extra costs

## Material:

- Glass: Borosilicate to DIN 7079

Nominal size DN			d6	d	d14	d7	d2	g1	S	O-Ring	
Series A	Series B	Series C									
DIN 11850	ISO 1127	ISO 2037									
		BS 4825									
20	-	-	25	35,9	17	24,9	30	27,97	7	11	22 x 3,5
25	-	-	25	42,9	20	30,9	35	33,97	9	12	28 x 3,5
-	33,7	-	25	48,9	23	36,35	41	40,36	10	13	32 x 5
32	-	-	25	48,9	23	38,65	41	42,66	10	13	34 x 5
-	-	1½"	25	54,9	30	41,45	48	45,46	10	14	37 x 5
40	-	-	25	54,9	28	44,65	48	48,66	10	14	40 x 5
-	42,4	-	25	54,9	28	45,05	48	49,06	10	14	40,5 x 5
-	48,3	-	25	66,9	34	50,95	61	54,96	11	14	46,5 x 5
-	-	2"	25	66,9	34	54,45	61	58,46	11	14	50 x 5
50	-	-	25	66,9	34	56,65	61	60,66	11	14	52 x 5
-	60,3	-	16	84,9	40	62,95	79	66,96	12	15	58,5 x 5
-	-	2½"	16	84,9	40	66,85	79	70,86	12	15	62 x 5
65	-	-	16	84,9	40	72,65	79	76,66	12	18	68 x 5
-	76,1	-	16	98,9	47	78,35	93	82,36	14	18	73,5 x 5
-	-	3"	16	98,9	47	79,55	93	83,56	14	18	75 x 5
80	-	-	16	98,9	47	87,65	93	91,66	14	18	83 x 5
-	88,9	-	16	118,9	55	90,95	114	94,96	15	21	86,5 x 5
-	-	4"	16	118,9	55	104,05	114	108,06	15	21	100 x 5
100	-	-	16	118,9	55	106,65	114	110,66	15	21	102 x 5

[www.armat.cz](http://www.armat.cz)

ARMAT spol. s r. o., 561 41 Řetová 82, Tel.: + 420 465 585 258, [armat@armat.cz](mailto:armat@armat.cz)