

# Threaded Sight Glass type 61NPT – NPT-Thread

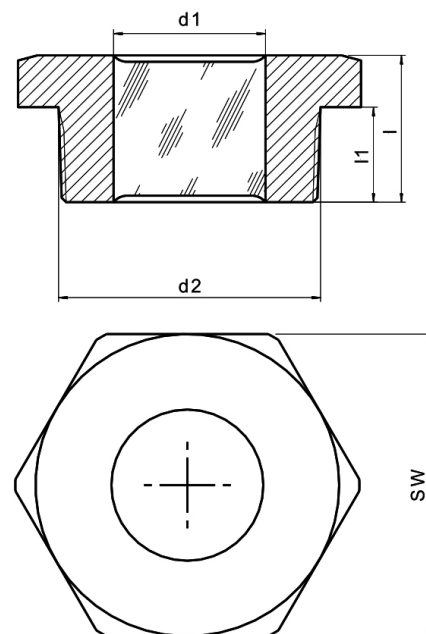
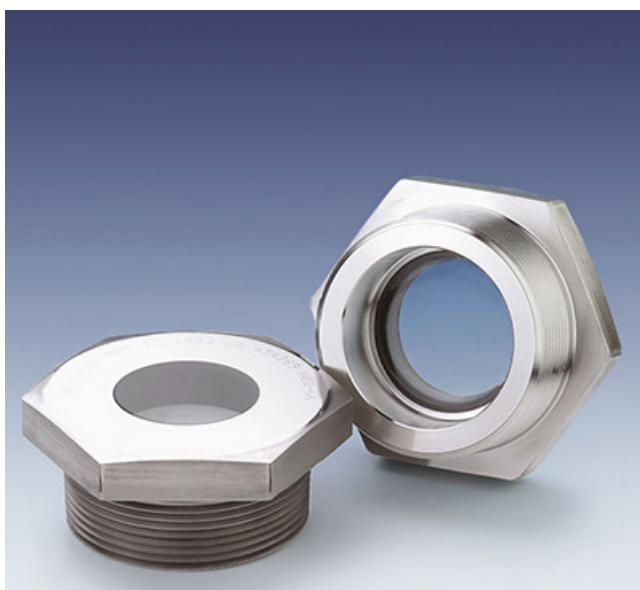

## Applications:

- Female connection with NPT or NPTF thread

## Advantages:

- Very compact
- High pressure resistance
- Simple assembly
- Long working time

## Operating conditions:

- Pressure: 100 bar
- Temperature: see table

Ring materials	Operating temperature
1.0570	-10 °C to +300 °C
1.4462	-30 °C to +280 °C
2.4602	-60 °C to +300 °C

## Technical data:

Manufactured and tested to::

- Directive for pressure equipment 2014/68/EU, Module H (DIN/EN/ISO 9001)
- AD 2000 Standards W0/TRD 100
- Sight glass fused to metal conforming to DIN 7079
- Materials to VdTÜV specifications and the DIN/EN designated standards

## Material certificates:

- Certificate of Conformity to EN 10204-3.1 or 3.2 for extra costs

## Materials:

- Ring material: Carbon Steel (1.0570), Stainless Steel (1.4462) Hastelloy
- Glass: Borosilicate to DIN 7080 / DIN 7079

d2 – Thread	SW	d1	d4	l	l1
¼" NPT	21	8	9	15	10
3/8" NPT	24	10	12	15	10
½" NPT	27	14	16	25	15
¾" NPT	36	18	20	26	16
1" NPT	41	22	23	28	18
1¼" NPT	50	25	30	30	20
1½" NPT	55	30	36	32	22
2" NPT	70	37	44	35	25
3" NPT	100	55	60	38	28