

**STAINLESS STEEL NEEDLE VALVE PN 400 M/F**



ISO 9001:2008  
BUREAU VERITAS  
Certification



**Size :** DN 1/4" to 1"  
**Ends :** Male - Female BSP  
**Min Temperature :** - 20°C  
**Max Temperature :** + 180°C  
**Max Pressure :** 400 Bars  
**Specifications :** Rotating rising stem  
1 piece type  
Reduced bore

**Materials :** SS ASTM A351 CF8M

**STAINLESS STEEL NEEDLE VALVE PN 400 M/F**

**SPECIFICATIONS :**

Respect the flow direction ( indicated by the arrow )  
 Reduced bore  
 Rising rotating stem  
 1 piece type  
 Stainless steel type  
 6000 Psi type ( PN400 )

**USE :**

For common fluids of 2<sup>nd</sup> group  
 Min and max Temperature Ts : - 20°C to + 180°C  
 Max Pressure PN : 400 bars ( see graph )

**PRESSURE / TEMPERATURE GRAPH ( STEAM EXCLUDED ) :**

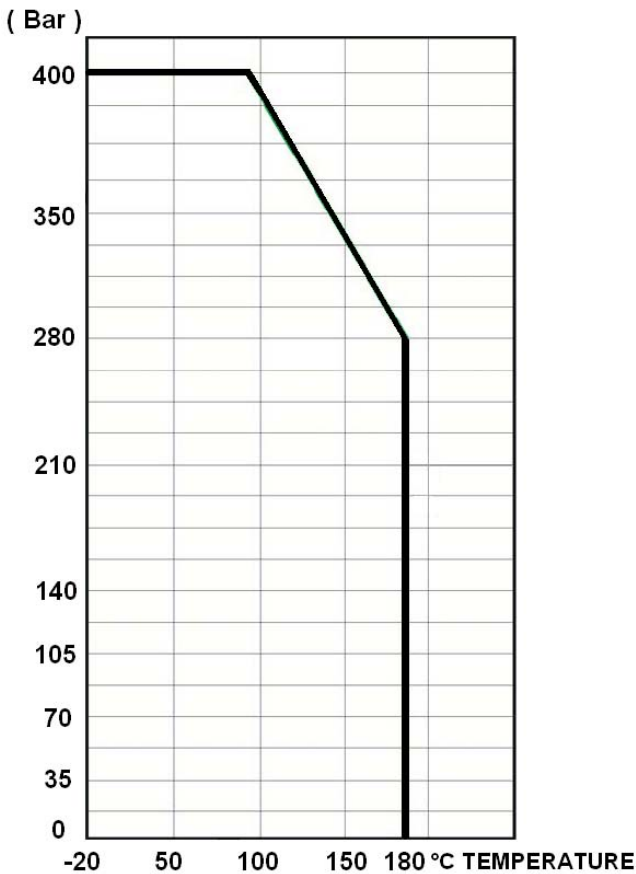

**FLOW COEFFICIENT Kvs ( m3 / h ) :**

DN	1/4"	3/8"	1/2"	3/4"	1"
Kvs ( m3 / h )	1.28	1.28	1.28	1.538	2.56

**STAINLESS STEEL NEEDLE VALVE PN 400 M/F**

**RANGE :**

Stainless steel needle valve threaded male - female BSP Ref. 488 from DN 1/4" to DN 1"

**MATERIALS :**

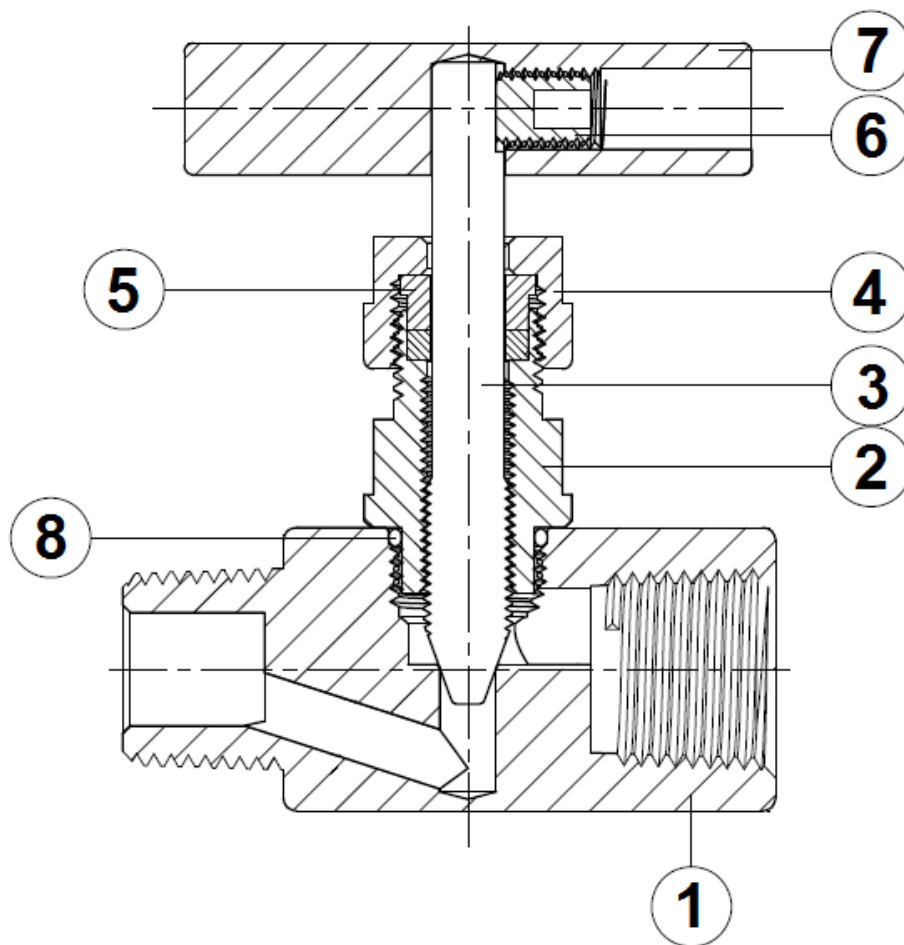

Item	Designation	Materials
1	Body	ASTM A351 CF8M
2	Bonnet	ASTM A240-304
3	Stem	ASTM A240-304
4	Packing nut	SS 304
5	Packing	PTFE
6	Handle screw	SS 304
7	Handle	SS 304
8	O ring	FKM

**STAINLESS STEEL NEEDLE VALVE PN 400 M/F**

SIZE ( in mm ) :

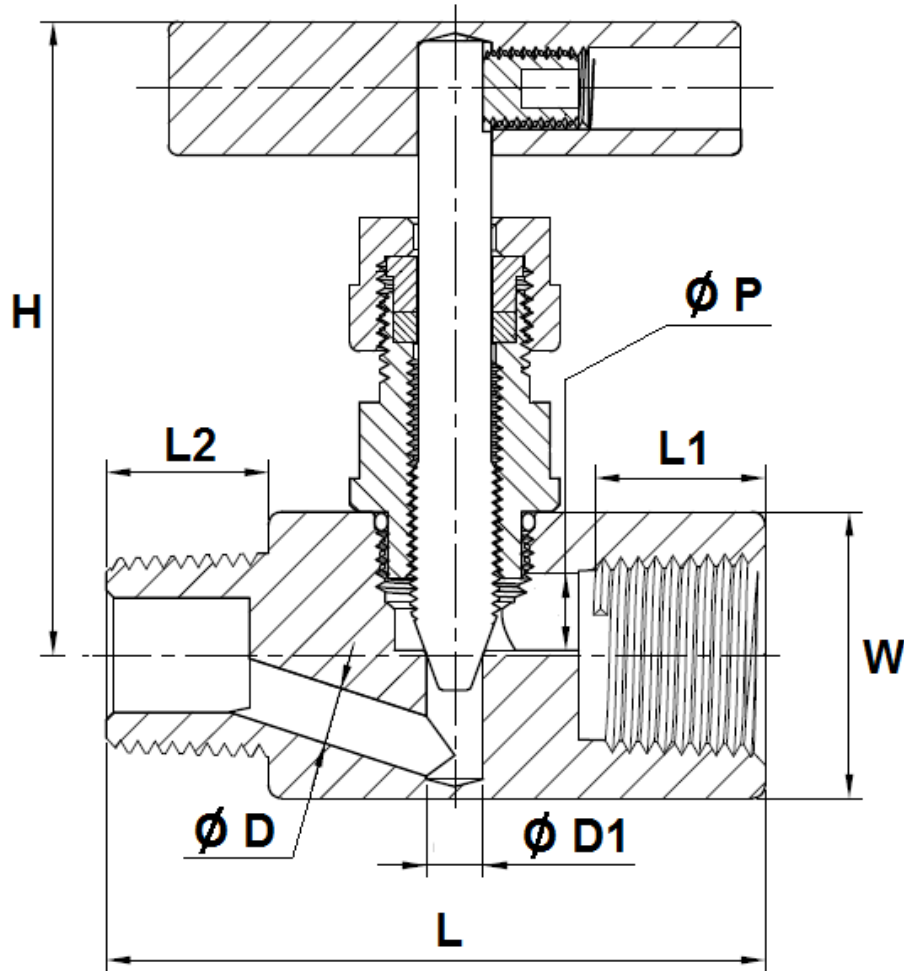

Ref.	DN	1/4"	3/8"	1/2"	3/4"	1"
488	L	58	60.5	69	76	83
	L1	9.5	12	16.3	17	19
	L2	14	15	17	18	21
	H	78.85	78.85	82.2	114.6	117.5
	W (on flat)	25.4	25.4	31.7	38	45
	Ø D	5	5	6	8	8
	Ø D1	6	6	6	8	8
	Ø P	6.3	6.3	8	10	10
	Weight (in Kg)	0.3	0.3	0.5	0.8	1.2

**STAINLESS STEEL NEEDLE VALVE PN 400 M/F****NUMBER OF TURNS TO CLOSE OR OPEN THE VALVE :**

DN	1/4"	3/8"	1/2"	3/4"	1"
Nb of turns	8	9	11	8	12

**STANDARDS :**

Fabrication according to ISO 9001 : 2008

Tests according to API 598, table 6

Threaded female BSP cylindrical ends according to ISO 7/1 Rp

Threaded male BSP conical ends according to ISO 7/1 R

DIRECTIVE 97/23/CE : Concerned by article 3, § 3

ATEX Group II Category 2 G/2D Zone 1 & 21 Zone 2 & 22 ( optional marking )

**ADVICE :** Our opinion and our advice are not guaranteed and SFERACO shall not be liable for the consequences of damages.  
The customer must check the right choice of the products with the real service conditions.

**STAINLESS STEEL NEEDLE VALVE PN 400 M/F****INSTALLATION INSTRUCTIONS****GENERAL GUIDELINES :**

Ensure that the valves to be used are appropriate for the conditions of the installation (type of fluid, pressure and temperature).

Be sure to have enough valves to be able to isolate the sections of piping as well as the appropriate equipment for maintenance and repair.

Ensure that the valves to be installed are of correct strength to be able to support the capacity of their usage.

**Installation of all circuits should ensure that their function can be automatically tested on a regular basis (at least two times a year).**

**INSTALLATION INSTRUCTIONS :**

**Before installing the valves, clean and remove any objects from the pipes** (in particular bits of sealing and metal) which could obstruct and block the valves.

**Ensure that both connecting pipes either side of the valve (upstream and downstream) are aligned (if they're not, the valves may not work correctly).**

**Make sure that the two sections of the pipe (upstream and downstream) match, the valve unit will not absorb any gaps. Any distortions in the pipes may affect the tightness of the connection, the working of the valve and can even cause a rupture.** To be sure, place the kit in position to ensure the assembling will work.

The theoretical lengths given by ISO/R7 for the tapping are typically longer than required, the length of the thread should be limited, and **check that the end of the tube does not press right up to the head of the thread.**

**Never use a vice to tighten the fixings of the valve.**

**If sections of piping do not have their final support in place, they should be temporarily fixed. This is to avoid unnecessary strain on the valve.**

**It may be necessary to screw the packing gland during using according to the type of use.**

**Do not use a tool to shut the valve**

**Fluids in the valve must not contain solid objects ( it could damaged the seat ).**

It's recommended to operate the valve ( open and close ) 1 to 2 times per year