

T-kus dlouhý DIN řada 1
přivařovací, redukovaný
AISI 304/L, AISI 316/L

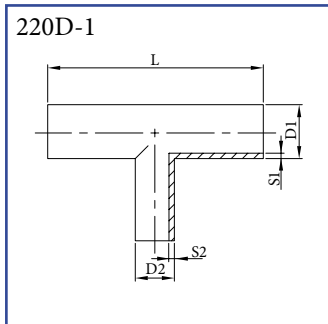

DN	D1	D2	S1	S2	L	kg
25/20	28,0	22,0	1,5	1,5	100,0	0,14
32/25	34,0	28,0	1,5	1,5	110,0	0,18
40/25	40,0	28,0	1,5	1,5	120,0	0,24
40/32	40,0	34,0	1,5	1,5	120,0	0,24
50/25	52,0	28,0	1,5	1,5	140,0	0,31
50/32	52,0	34,0	1,5	1,5	140,0	0,31
50/40	52,0	40,0	1,5	1,5	140,0	0,31
65/25	70,0	28,0	2,0	1,5	160,0	0,65
65/32	70,0	34,0	2,0	1,5	160,0	0,65
65/40	70,0	40,0	2,0	1,5	160,0	0,65
65/50	70,0	52,0	2,0	1,5	160,0	0,65
80/25	85,0	28,0	2,0	1,5	180,0	1,07
80/32	85,0	34,0	2,0	1,5	180,0	1,07
80/40	85,0	40,0	2,0	1,5	180,0	1,07
80/50	85,0	52,0	2,0	1,5	180,0	1,07
80/65	85,0	70,0	2,0	2,0	180,0	1,07
100/25	104,0	28,0	2,0	1,5	200,0	1,85
100/32	104,0	34,0	2,0	1,5	200,0	1,85
100/40	104,0	40,0	2,0	1,5	200,0	1,85
100/50	104,0	52,0	2,0	1,5	200,0	1,85
100/65	104,0	70,0	2,0	2,0	200,0	1,85
100/80	104,0	85,0	2,0	2,0	200,0	1,85
125/25	129,0	28,0	2,0	1,5	374,0	1,97
125/32	129,0	34,0	2,0	1,5	374,0	1,97
125/40	129,0	40,0	2,0	1,5	374,0	1,97
125/50	129,0	52,0	2,0	1,5	374,0	1,97
125/65	129,0	70,0	2,0	2,0	374,0	1,97
125/80	129,0	85,0	2,0	2,0	374,0	1,97
125/100	129,0	104,0	2,0	2,0	374,0	1,97
150/25	154,0	28,0	2,0	1,5	450,0	2,89
150/32	154,0	34,0	2,0	1,5	450,0	2,89
150/40	154,0	40,0	2,0	1,5	450,0	2,89
150/50	154,0	52,0	2,0	1,5	450,0	2,89
150/65	154,0	70,0	2,0	2,0	450,0	2,89
150/80	154,0	85,0	2,0	2,0	450,0	2,89
150/100	154,0	104,0	2,0	2,0	450,0	2,89
150/125	154,0	129,0	2,0	2,0	450,0	2,89

T-kus dlouhý DIN řada 2
přivařovací, redukovaný
AISI 304/L, AISI 316/L

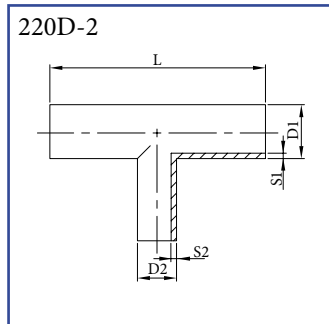

DN	D1	D2	S1	S2	L	kg
25/20	29,0	23,0	1,5	1,5	100,0	0,14
32/25	35,0	29,0	1,5	1,5	110,0	0,18
40/25	41,0	29,0	1,5	1,5	120,0	0,24
40/32	41,0	35,0	1,5	1,5	120,0	0,24
50/25	53,0	29,0	1,5	1,5	140,0	0,31
50/32	53,0	35,0	1,5	1,5	140,0	0,31
50/40	53,0	41,0	1,5	1,5	140,0	0,31
65/25	70,0	29,0	2,0	1,5	160,0	0,65
65/32	70,0	35,0	2,0	1,5	160,0	0,65
65/40	70,0	41,0	2,0	1,5	160,0	0,65
65/50	70,0	53,0	2,0	1,5	160,0	0,65
80/25	85,0	29,0	2,0	1,5	180,0	1,07
80/32	85,0	35,0	2,0	1,5	180,0	1,07
80/40	85,0	41,0	2,0	1,5	180,0	1,07
80/50	85,0	53,0	2,0	1,5	180,0	1,07
100/25	104,0	29,0	2,0	1,5	200,0	1,85
100/32	104,0	35,0	2,0	1,5	200,0	1,85
100/40	104,0	41,0	2,0	1,5	200,0	1,85
100/50	104,0	53,0	2,0	1,5	200,0	1,85
125/25	129,0	29,0	2,0	1,5	374,0	2,00
125/32	129,0	35,0	2,0	1,5	374,0	2,00
125/40	129,0	41,0	2,0	1,5	374,0	2,00
125/50	129,0	53,0	2,0	1,5	374,0	2,00
150/25	154,0	29,0	2,0	1,5	450,0	2,95
150/32	154,0	35,0	2,0	1,5	450,0	2,95
150/40	154,0	41,0	2,0	1,5	450,0	2,95
150/50	154,0	53,0	2,0	1,5	450,0	2,95

T-kus dlouhý SMS
přivařovací, redukovaný
AISI 304/L, AISI 316/L

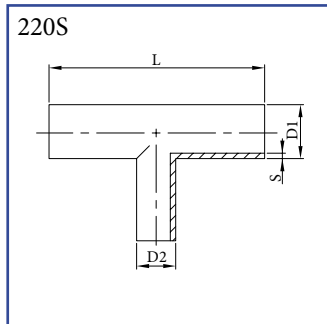

DN	D1	D2	S	L	kg
38/25	38,1	25,4	1,5	140,0	0,32
51/25	50,8	25,4	1,5	164,0	0,47
51/38	50,8	38,1	1,5	164,0	0,47
63/38	63,5	38,1	1,5	210,0	0,68
63/51	63,5	50,8	1,5	210,0	0,68
76/38	76,2	38,1	1,65	220,0	1,03
76/51	76,2	50,8	1,65	220,0	1,03
76/63	76,2	63,5	1,65	220,0	1,03
101/63	101,6	63,5	2,0	300,0	1,85
101/76	101,6	76,2	2,0	300,0	1,85

T-kus dlouhý ISO
přivařovací, redukovaný
AISI 304/L, AISI 316/L

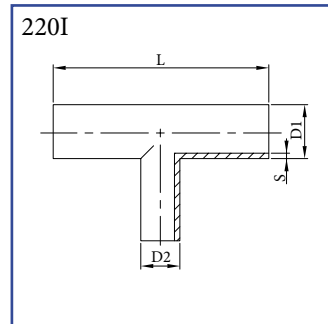

DN	D	D2	S	L	kg
15	21,3				
20	26,9				
25	33,7				
32	42,4				
40	48,3				
50	60,3				
65	76,1				
80	88,9				
100	114,3				
125	139,7				

Rozměry na požádání