

Redukce souosá DIN řada 1
přivařovací
AISI 304/L, AISI 316/L

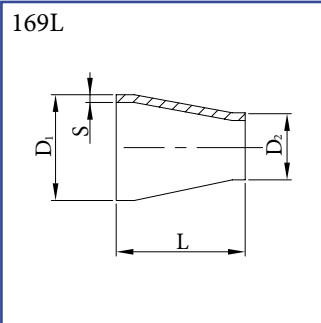

Redukce souosá DIN řada 1
přivařovací - dlouhá
AISI 304/L, AISI 316/L

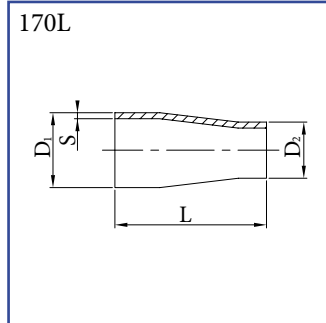

Redukce souosá DIN řada 1
přivařovací - krátká
AISI 304/L, AISI 316/L

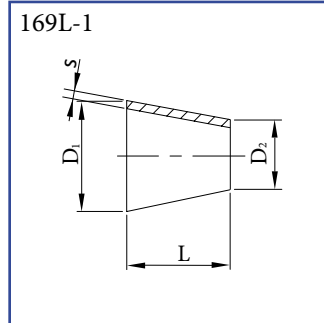

Redukce souosá DIN řada 2
přivařovací - krátká
AISI 304/L, AISI 316/L

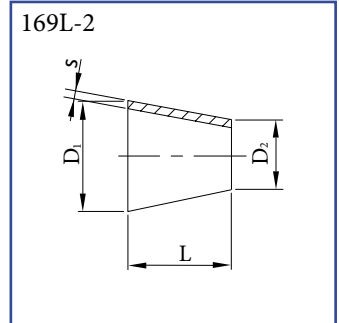

DN	D1	D2	S	L	kg
15/10	18,0	12,0	1,5	38,0	0,03
20/10	22,0	12,0	1,5	38,0	0,04
20/15	22,0	18,0	1,5	38,0	0,04
25/10	28,0	12,0	1,5	38,0	0,05
25/15	28,0	18,0	1,5	38,0	0,05
25/20	28,0	22,0	1,5	38,0	0,05
32/25	34,0	28,0	1,5	67,0	0,06
40/25	40,0	28,0	1,5	67,0	0,06
40/32	40,0	34,0	1,5	67,0	0,06
50/25	52,0	28,0	1,5	67,0	0,10
50/32	52,0	34,0	1,5	67,0	0,10
50/40	52,0	40,0	1,5	67,0	0,11
65/40	70,0	40,0	2,0	67,0	0,12
65/50	70,0	52,0	2,0	67,0	0,16
80/40	85,0	40,0	2,0	88,0	0,18
80/50	85,0	52,0	2,0	67,0	0,19
80/65	85,0	70,0	2,0	67,0	0,24
100/50	104,0	52,0	2,0	107,0	0,30
100/65	104,0	70,0	2,0	72,0	0,29
100/80	104,0	85,0	2,0	67,0	0,28

DN	D1	D2	S	L	kg
15/10	18,0	12,0	1,25	67,0	0,03
20/10	22,0	12,0	1,25	67,0	0,04
20/15	22,0	18,0	1,25	67,0	0,04
25/10	28,0	12,0	1,5	67,0	0,05
25/15	28,0	18,0	1,5	67,0	0,05
25/20	28,0	22,0	1,5	67,0	0,05
32/10	34,0	12,0	1,5	67,0	0,08
32/15	34,0	18,0	1,5	67,0	0,08
32/20	34,0	22,0	1,5	98,0	0,09
32/25	34,0	28,0	1,5	88,0	0,09
40/10	40,0	12,0	1,5	67,0	0,10
40/15	40,0	18,0	1,5	67,0	0,11
40/20	40,0	22,0	1,5	105,0	0,11
40/25	40,0	28,0	1,5	98,0	0,12
40/32	40,0	34,0	1,5	88,0	0,12
50/25	52,0	28,0	1,5	134,0	0,16
50/32	52,0	34,0	1,5	105,0	0,21
50/40	52,0	40,0	1,5	98,0	0,18
65/32	70,0	34,0	2,0	120,0	0,22
65/40	70,0	40,0	2,0	120,0	0,22
65/50	70,0	52,0	2,0	105,0	0,27
80/40	85,0	40,0	2,0	147,0	0,44
80/50	85,0	52,0	2,0	125,0	0,43
80/65	85,0	70,0	2,0	105,0	0,50
100/50	104,0	52,0	2,0	165,0	0,53
100/65	104,0	70,0	2,0	127,0	0,525
100/80	104,0	85,0	2,0	120,0	0,55

DN	D1	D2	S	L*	kg
15/10	18,0	12,0	1,5	11,5	0,01
20/10	22,0	12,0	1,5	15,0	0,02
20/15	22,0	18,0	1,5	22,0	0,03
25/10	28,0	12,0	1,5	25,0	0,02
25/15	28,0	18,0	1,5	15,0	0,05
25/20	28,0	22,0	1,5	17,0	0,05
32/10	34,0	12,0	1,5	30,0	0,03
32/15	34,0	18,0	1,5	30,0	0,03
32/20	34,0	22,0	1,5	18,0	0,06
32/25	34,0	28,0	1,5	19,5	0,06
40/15	40,0	18,0	1,5	30,0	0,04
40/20	40,0	22,0	1,5	30,0	0,04
40/25	40,0	28,0	1,5	19,0	0,06
40/32	40,0	34,0	1,5	20,5	0,06
50/25	52,0	28,0	1,5	71,0	0,08
50/32	52,0	34,0	1,5	26,5	0,07
50/40	52,0	40,0	1,5	28,5	0,07
65/40	70,0	40,0	2,0	38,0	0,10
65/50	70,0	52,0	2,0	29,0	0,10
80/40	85,0	40,0	2,0	92,0	0,16
80/50	85,0	52,0	2,0	46,0	0,11
80/65	85,0	70,0	2,0	34,5	0,11
100/65	104,0	70,0	2,0	44,5	0,28
100/80	104,0	85,0	2,0	45,0	0,17
125/65	129,0	70,0	2,0	106,0	0,44
125/80	129,0	85,0	2,0	79,0	0,41
125/100	129,0	104,0	2,0	45,0	0,55
150/80	154,0	85,0	2,0	124,0	0,50
150/100	154,0	104,0	2,0	90,0	0,45
150/125	154,0	129,0	2,0	45,0	0,40
200/150	204,0	154,0	2,0	90,0	0,79

* rozměr na poptávku
délka redukcí se může měnit dle
aktuálních skladových zásob
dle požadavků zákazníků

DN	D1	D2	S	L*	kg
15/10	19,0	13,0	1,5	11,0	0,01
20/10	23,0	13,0	1,5	18,0	0,02
20/15	23,0	19,0	1,5	7,0	0,01
25/10	29,0	13,0	1,5	28,0	0,02
25/15	29,0	19,0	1,5	18,0	0,02
25/20	29,0	23,0	1,5	11,0	0,01
32/15	35,0	19,0	1,5	28,0	0,03
32/20	35,0	23,0	1,5	22,0	0,02
32/25	35,0	29,0	1,5	11,0	0,02
40/20	41,0	23,0	1,5	33,0	0,04
40/25	41,0	29,0	1,5	22,0	0,03
40/32	41,0	35,0	1,5	11,0	0,04
50/25	53,0	29,0	1,5	44,0	0,08
50/32	53,0	35,0	1,5	33,0	0,08
50/40	53,0	41,0	1,5	22,0	0,09
65/32	70,0	35,0	2,0	62,0	0,12
65/40	70,0	41,0	2,0	51,0	0,11
65/50	70,0	53,0	2,0	29,0	0,09
80/40	85,0	41,0	2,0	92,0	0,16
80/50	85,0	53,0	2,0	56,0	0,12
100/50	104,0	53,0	2,0	90,0	0,29

* rozměr na poptávku
délka redukcí se může měnit dle
aktuálních skladových zásob,
dle požadavků zákazníků

Redukce excentrická DIN-1
přivařovací
AISI 304/L, AISI 316/L

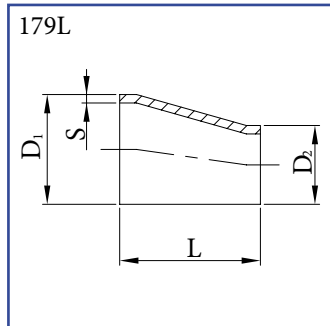

DN	D1	D2	S	L	kg
32/25	34,0	28,0	1,5	67,0	0,06
40/25	40,0	28,0	1,5	67,0	0,06
40/32	40,0	34,0	1,5	67,0	0,06
50/25	52,0	28,0	1,5	68,0	0,10
50/32	52,0	34,0	1,5	67,0	0,10
50/40	52,0	40,0	1,5	67,0	0,11
65/40	70,0	40,0	2,0	71,0	0,12
65/50	70,0	52,0	2,0	67,0	0,16
80/50	85,0	52,0	2,0	79,0	0,19
80/65	85,0	70,0	2,0	67,0	0,24
101/50	101,6	52,0	2,0	110,0	0,30
101/65	101,6	70,0	2,0	67,0	0,29
101/80	101,6	85,0	2,0	67,0	0,28

Redukce excentrická DIN-1
přivařovací - dlouhá
AISI 304/L, AISI 316/L

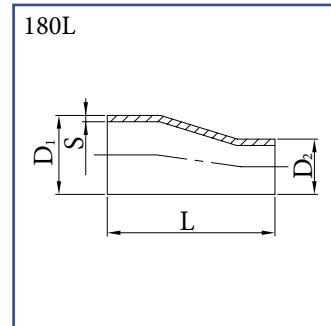

DN	D1	D2	S	L	kg
32/25	34,0	28,0	1,5	102,0	0,12
40/25	40,0	28,0	1,5	110,0	0,12
40/32	40,0	34,0	1,5	102,0	0,13
50/25	52,0	28,0	1,5	130,0	0,16
50/32	52,0	34,0	1,5	120,0	0,20
50/40	52,0	40,0	1,5	110,0	0,16
65/40	70,0	40,0	2,0	153,0	0,23
65/50	70,0	52,0	2,0	130,0	0,24
80/50	85,0	52,0	2,0	146,0	0,43
80/65	85,0	70,0	2,0	120,0	0,50
101/50	101,6	52,0	2,0	150,0	0,56
101/65	101,6	70,0	2,0	153,0	0,55
101/80	101,6	85,0	2,0	118,0	0,55

Redukce excentrická DIN-1
přivařovací - krátká
AISI 304/L, AISI 316/L

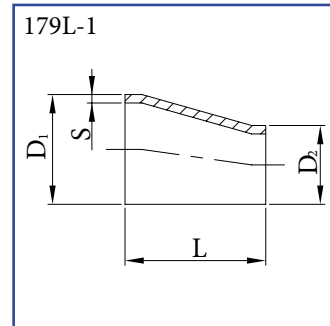

DN	D1	D2	S	L	kg
15/10	18,0	12,0	1,5	25,0	0,01
20/10	22,0	12,0	1,5	30,0	0,02
25/10	28,0	12,0	1,5	35,0	0,02
25/15	28,0	18,0	1,5	30,0	0,02
25/20	28,0	22,0	1,5	30,0	0,03
32/20	34,0	22,0	1,5	35,0	0,03

Redukce excentrická DIN-2
přivařovací - krátká
AISI 304/L, AISI 316/L

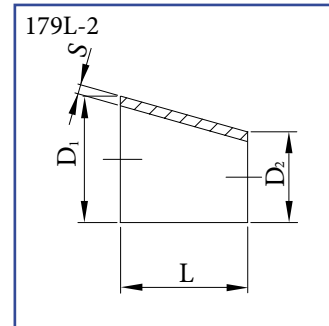

DN	D1	D2	S	L	kg
15/10	19,0	13,0	1,5	16,5	0,01
20/10	23,0	13,0	1,5	27,5	0,02
20/15	23,0	19,0	1,5	11,0	0,01
25/10	29,0	13,0	1,5	44,0	0,01
25/15	29,0	19,0	1,5	27,5	0,02
25/20	29,0	23,0	1,5	16,5	0,03
32/15	35,0	19,0	1,5	44,0	0,03
32/20	35,0	23,0	1,5	33,0	0,03
32/25	35,0	29,0	1,5	16,5	0,04
40/15	41,0	19,0	1,5	60,5	0,05
40/20	41,0	23,0	1,5	49,5	0,04
40/25	41,0	29,0	1,5	33,0	0,05
40/32	41,0	35,0	1,5	16,5	0,07
50/25	53,0	29,0	1,5	66,0	0,08
50/32	53,0	35,0	1,5	49,5	0,11
50/40	53,0	41,0	1,5	33,0	0,07
65/40	70,0	41,0	2,0	77,0	0,17
65/50	70,0	53,0	2,0	44,0	0,11
80/50	85,0	53,0	2,0	85,0	0,21
80/65	85,0	70,0	2,0	41,2	0,14
100/50	104,0	53,0	2,0	137,5	0,80
100/65	104,0	70,0	2,0	93,5	0,34
100/80	104,0	85,0	2,0	52,5	0,20
125/80	129,0	85,0	2,0	121,0	0,38
125/100	129,0	104,0	2,0	68,5	0,28
150/100	154,0	104,0	2,0	137,5	0,53
150/125	154,0	129,0	2,0	68,5	0,29