

Filtr přímý
přivařovací
AISI 304L, AISI 316L

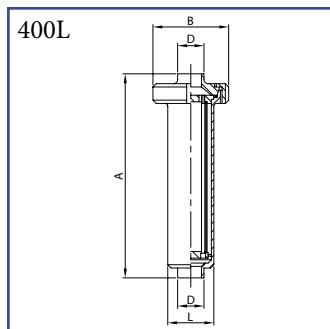

DN	A	B	D	L	Kg
25	320,0	112,0	25,4	70,0	3,00
38	320,0	112,0	38,1	70,0	3,00
51	420,0	112,0	50,8	70,0	3,30
63	516,0	127,0	63,5	85,0	4,65
76	574,0	148,0	76,2	102,0	5,70
101	700,0	148,0	101,6	129,0	7,00

Filtr přímý
závit / konec na zaválcování
AISI 304L, AISI 316L

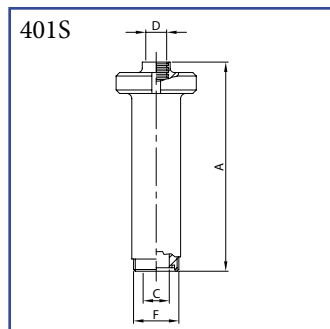

DN	A	C	D	F	Kg
25	327,0	22,4	25,4	40-6	3,07
38	327,0	35,1	38,1	60-6	3,20
51	427,0	47,8	50,8	70-6	3,53
63	529,0	60,5	63,5	85-6	5,04
76	594,0	72,9	76,2	98-6	6,20
101	700,0	97,6	101,6	132-6	8,14

Filtr 90°
přivařovací
AISI 304L, AISI 316L

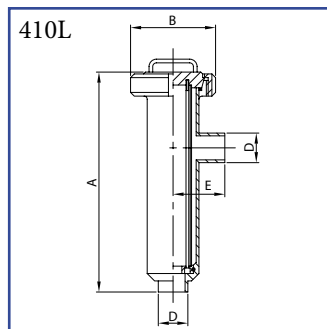

DN	A	B	D	E	Kg
25	307,0	112,0	25,4	70,0	3,10
38	307,0	112,0	38,1	70,0	3,10
51	407,0	112,0	50,8	82,0	3,40
63	503,0	127,0	63,5	85,0	4,80
76	561,0	148,0	76,2	96,0	5,90
101	662,0	148,0	101,6	117,0	7,20

Filtr 90°
závit / svár
AISI 304L, AISI 316L

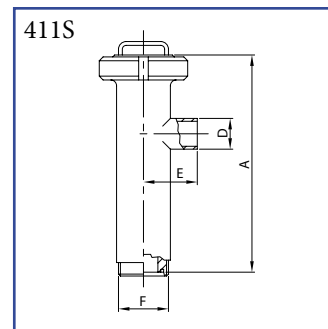

DN	A	D	E	F	Kg
25	306,0	25,4	70,0	40-6	3,17
38	306,0	38,1	70,0	60-6	3,30
51	405,0	50,8	72,0	70-6	3,62
63	503,0	63,5	85,0	85-6	5,19
76	561,0	76,2	96,0	98-6	6,40
101	652,0	101,6	117,0	132-6	8,34

Filtr 90°
se závitovými konci
AISI 304L, AISI 316L

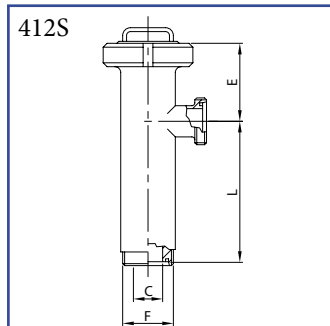

DN	C	E	F	L	Kg
25	22,4	99,0	40-6	207,0	3,24
38	35,1	99,0	60-6	207,0	3,50
51	47,8	115,0	70-6	290,0	3,85
63	60,5	117,0	85-6	386,0	5,58
76	72,9	131,0	98-6	430,0	6,90
101	97,6	120,0	132-6	532,0	9,48



- snadný přístup k vnitřním částem filtru
- standardní produkce: filtrační síto s otvory o průměru 1 mm
na přání také s otvory o průměru 0,5 - 2 - 3 mm
(nebo s filtrační vložkou, viz tabulka dále)
- standardní povrch: zrnitost 120 - vnější povrch leštěn, vnitřní glazura, ostatní na poptávku
- maximální provozní tlak: 5 bar

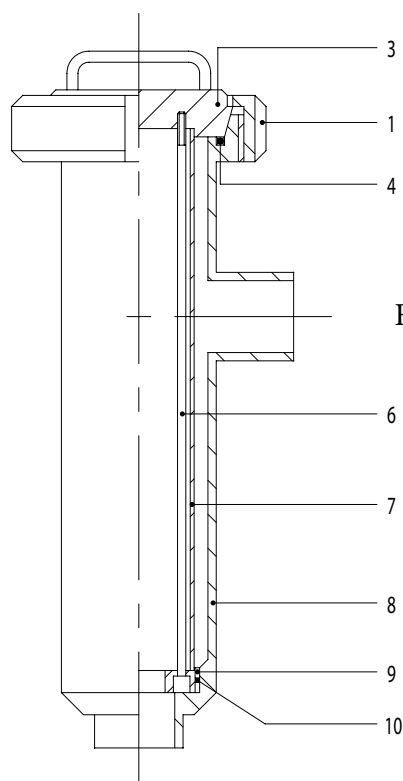

Filtr 90°

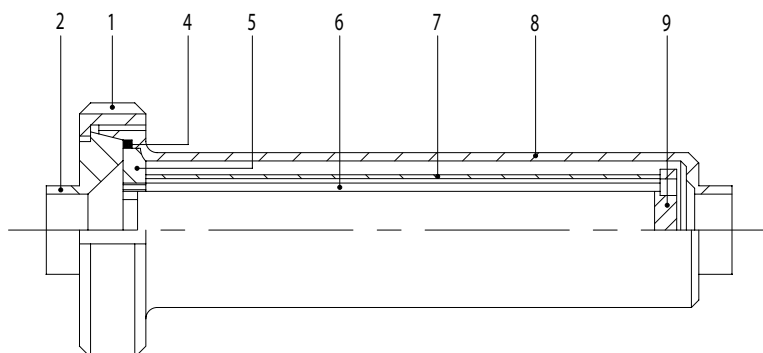

Filtr přímý

1. matice
2. přivařovací konec
3. uzávěr
4. těsnění
5. horní disk
6. svorník
7. filtr
8. kryt filtru
9. dolní disk
10. O-kroužek

Pozice	Kód filtr přímý	Kód filtr 90°	Nor-ma	1" 25	D25 28	D32 34	1 1/2" 38	D40 40	2" 51	D50 52	2 1/2" 63	D65 70	3" 76	D80 85	4" 101	D100 101	4" 104	D100 104	Mat.
1	121	121	D	65	65	65	65	65	65	65	80	80	100	100	100	100	100	100	4L/6L
2	116		D	65/25	65/28	65/34	65/38	65/40	65/51	65/52	80/63	80/70	100/76	100/85	100/101	100/101	100/104	100/104	4L/6L
3		410		65	65	65	65	65	65	65	80	80	100	100	100	100	100	100	4L/6L
4	131	131	D	65	65	65	65	65	65	65	80	80	100	100	100	100	100	100	N
5	400			25/52	25/52	25/52	25/52	25/52	25/52	25/52	63/70	63/70	76/85	76/85	101	101	101	101	6L
6	400	410		25/40	25/40	25/40	25/40	25/40	51/52	51/52	63/70	63/70	76/85	76/85	101	101	101	101	6L
7	400	410		25/52	25/52	25/52	25/52	25/52	25/52	25/52	63/70	63/70	76/85	76/85	101	101	101	101	6L
8	400	410		25/40	25/40	25/40	25/40	25/40	51/52	51/52	63/70	63/70	76/85	76/85	101	101	101	101	4L/6L
9	400	410	L	25	28	34	38	40	51	52	63	70	76	85	101	101	101	101	6L
10		OR		159	159	159	159	159	159	159	174	174	4350	4350	3375	3375	3375	3375	N

Průtoková rychlost m³/h

Rychlost kapaliny m / sec	0,50	1,0	1,5	2,0
25,4	0,745	1,494	2,239	2,988
28	0,882	1,764	2,646	3,528
34	1,447	2,894	4,341	5,788
38,1	1,785	3,571	5,356	7,142
40	2,041	4,082	6,123	8,164
50,8	3,294	6,588	9,882	13,176
52	3,531	7,063	10,594	14,126
63,5	5,191	10,382	15,573	20,764
70	6,152	11,336	18,460	24,616
76,2	7,509	15,019	22,528	30,038
85	9,270	18,540	27,810	37,080
101,6	14,130	28,260	42,390	56,520

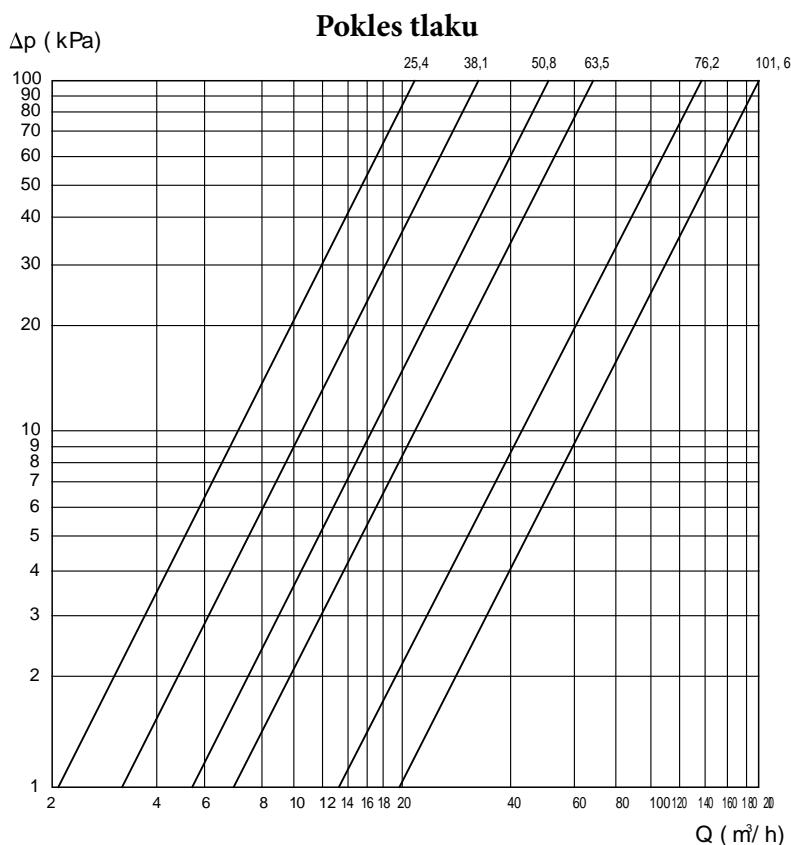

Tabulka dostupných vložek do filtrů

Mesh	Mikron (0,001 mm)	Milimetry
66	300	0,3
80	220	0,22
100	180	0,18
150	120	0,12
200	86	0,08
250	59	0,06
300	50	0,05
400	35	0,03
500	26	0,02