

2 PIECES STAINLESS STEEL BALL VALVE PN63 INITIAL RANGE

 **armat**
spol. s r.o.
MADE OF STAINLESS ...



PED 2014/68/EU



Certificate 3.1



Size : DN 1/4" to 4"
Ends : Threaded BSP (ISO 228-1)
Min Temperature : - 20°C
Max Temperature : + 180°C
Max Pressure : 63 Bars (up to DN3/4")
Specifications : Anti blow-out stem
Locking device
Full bore

Materials : Stainless steel ASTM A351 CF8M

2 PIECES STAINLESS STEEL BALL VALVE PN63 INITIAL RANGE

SPECIFICATIONS :

Full bore
Anti blow-out stem
PTFE packing
PTFE filled with 15% glass fiber seat
Locking device
Solid ball
2 pieces type

USE :

Chemical and pharmaceutical industries, petrochemical industries, hydraulic installation, compressed air
Min and max Temperature Ts : -20°C to + 180°C
Max Pressure Ps : 63 bars up to DN3/4", 50 bars from 1" to 1"1/4, 40 bars from 1"1/2 to 2" , 25 bars from 2"1/2 to 3", 16 bars for DN4" (see graph)

PRESSURE / TEMPERATURE GRAPH (STEAM EXCLUDED) :

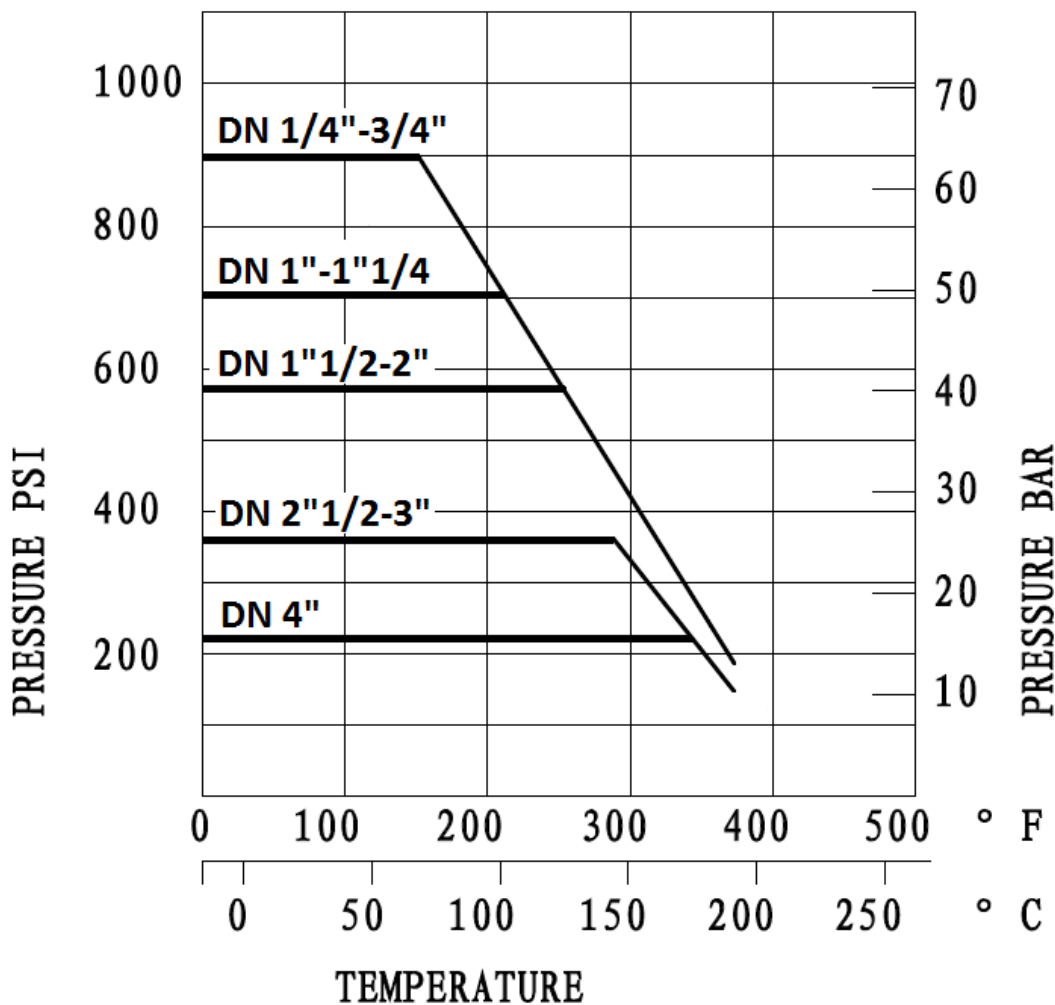

2 PIECES STAINLESS STEEL BALL VALVE PN63 INITIAL RANGE

RANGE :



Ball valve female / female threaded BSP Stainless steel blue handle Initial range Ref. 7151 from DN 1/4" to DN 4"

MATERIALS :

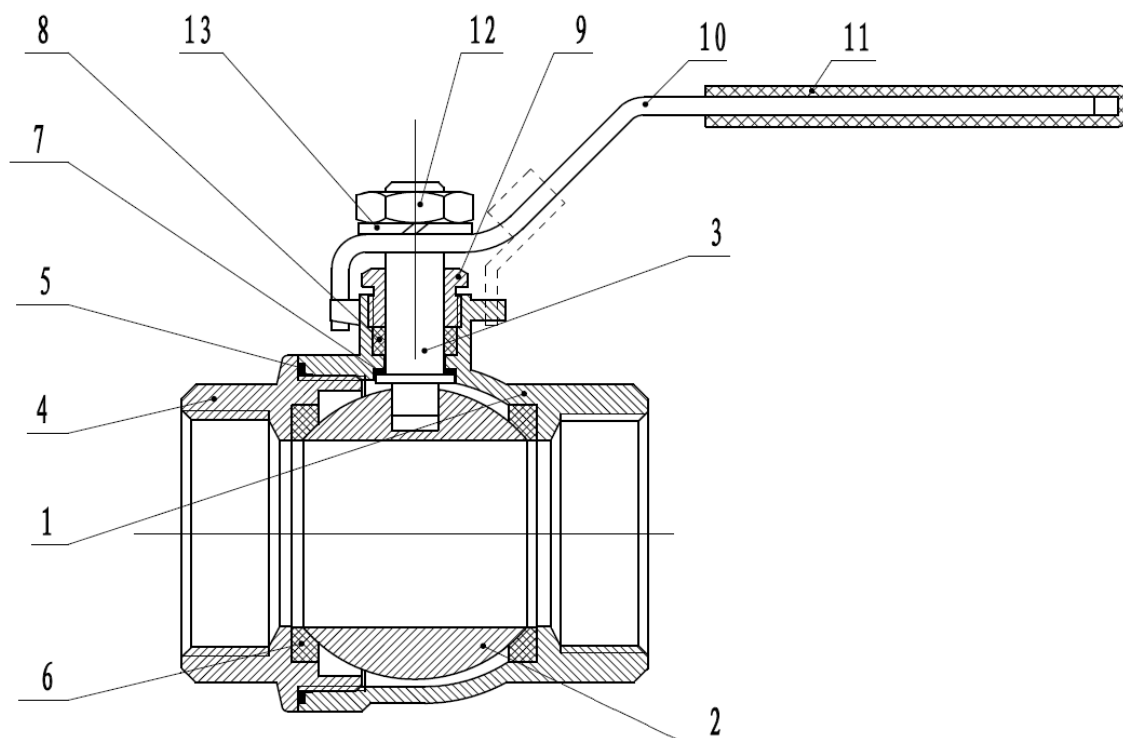

Item	Designation	Materials
1	Body	ASTM A351 CF8M
2	Ball	ASTM A351 CF8M
3	Stem	AISI 316
4	Ends	ASTM A351 CF8M
5	Body seal	PTFE
6	Seat	PTFE filled with 15% glass fiber
7	Stem gasket	PTFE
8	Packing	PTFE
9	Packing nut	AISI 304
10	Handle	AISI 304
11	Handle cover	Plastic
12	Handle nut	AISI 304
13	Handle washer	AISI 304

2 PIECES STAINLESS STEEL BALL VALVE PN63 INITIAL RANGE

SIZE (in mm) :

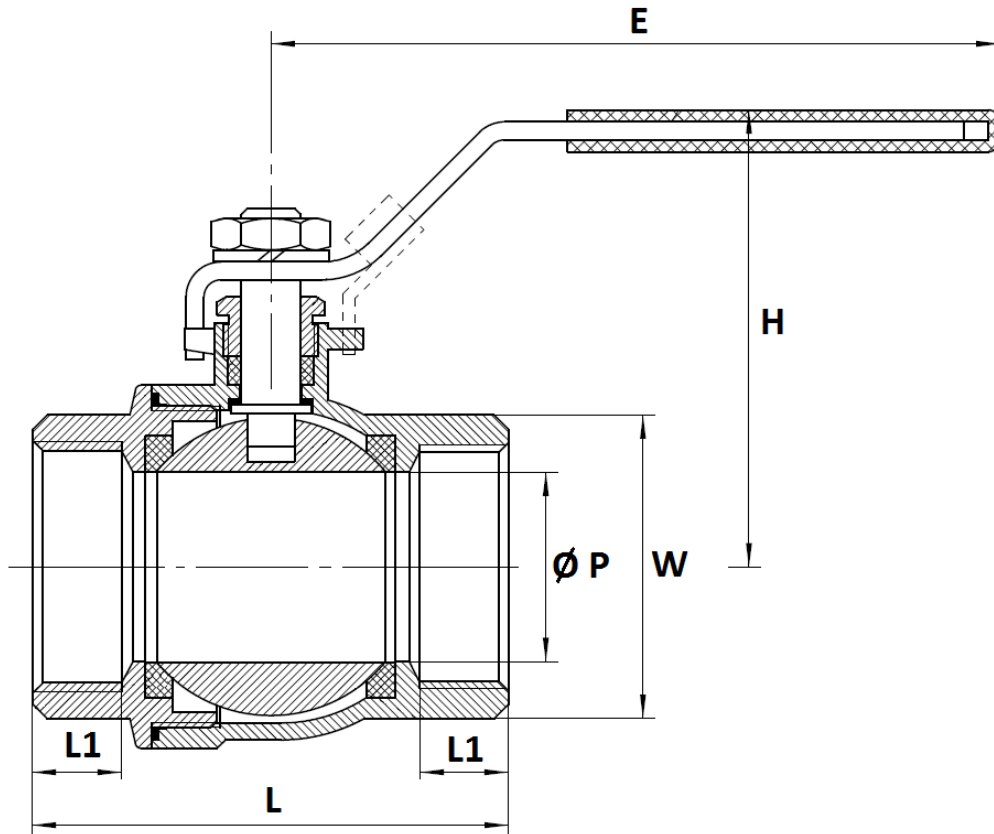

Stem size :

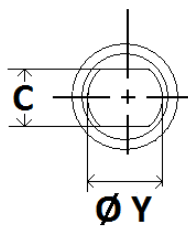

DN	1/4"	3/8"	1/2"	3/4"	1"	1"1/4	1"1/2	2"	2"1/2	3"	4"
Ø P	9.2	12.5	15	20	25	32	38	50	65	80	100
L	36	42	48	58	68.5	80	90.5	109	139	157	200
E	78	78	87	97	123	123	152	152	220	220	305
H	41	46	50	57	68	77	85	94	126	138	163
L1	6.5	7	7	9	11	12	13	17	21	23	30
W on flat	18	21	25	31	37.5	46.5	53	66	83	97.5	126
C	4	4	5	5	7	7	9	9	12	12	16
Ø Y	6	6	8	8	10	10	12	12	20	20	22
Weight (Kg)	0.11	0.14	0.22	0.33	0.53	0.82	1.27	2.04	4.75	6.72	10.3

2 PIECES STAINLESS STEEL BALL VALVE PN63 INITIAL RANGE
TORQUE VALUES (in Nm without safety coefficient) :

DN	1/4"	3/8"	1/2"	3/4"	1"	1"1/4"	1"1/2"	2"	2"1/2"	3"	4"
Torque (Nm)	3	4	6	8	10	20	30	35	60	70	130

FLOW COEFFICIENT Kvs (M3 / h) :

DN	1/4"	3/8"	1/2"	3/4"	1"	1"1/4"	1"1/2"	2"	2"1/2"	3"	4"
Kvs (m3/h)	6.6	7.9	11.2	21	35	57	80	150	265	415	780

STANDARDS :

Fabrication according to ISO 9001 : 2008

DIRECTIVE 2014/68/EU : CE N° 0036
 Risk Category III Module H

Certificate 3.1 on request

Pressure Tests according to EN 12266-1, rate A

Threaded BSP cylindrical ends according to ISO 228-1

ADVICE : Our opinion and our advice are not guaranteed and SFERACO shall not be liable for the consequences of damages.
 The customer must check the right choice of the products with the real service conditions.

2 PIECES STAINLESS STEEL BALL VALVE PN63 INITIAL RANGE

INSTALLATION AND MAINTENANCE

BEFORE INSTALLATION :

Pipe-line must be cleaned and free from residual of weldings, rubbish, shaving and every kind of extraneous materials.
Pipe-line must be perfectly aligned and their support properly dimensioned so that there's no external constraint.

Please use the right product according to the services conditions to seal the valve.
Use the right bolt tightening so that the ends won't be damaged.

CLEANING AND TESTS

Keep closed the valves during the cleaning operation so that there's no impurities between the ball and the body.

Tests under pressure must be done with a cleaned pipe-line.

Open partially the valve for tests. Pressure test do not exceed the valve specifications according to EN 12266-1.

MAINTENANCE

It's recommended to operate the valve twice (open and close) 1 to 2 times per year.

When intervention on the valve, be sure there's no pressure in the pipe-line, there's no fluid in it, and that it is isolated.
The temperature must be low enough to operate without risks.
If there's a corrosive fluid, inert installation before intervention.

When the valve is under pressure :

If there's a leakage at the packing, tighten it slightly so that the leakage disappears.