

THREADED FITTINGS BSP (150 lbs)

Welding nipple
outside thread taper ISO 7-1R ⁽¹⁾
material: AISI 316 (304 / 316Ti)

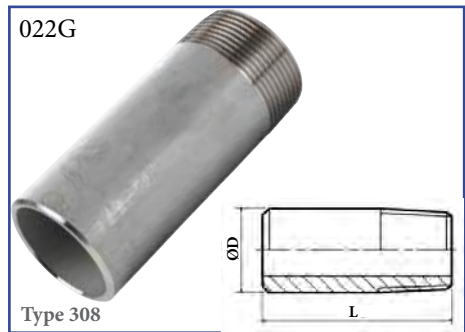

Barrel nipple
outside threads taper ISO 7-1R ⁽¹⁾
material: AISI 316 (304 / 316Ti)

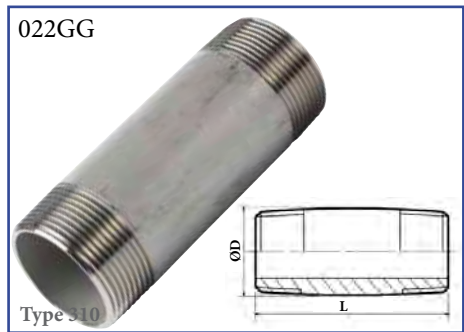

Parallel nipple
outside thread parallel ISO 228-1G
material: AISI 316 (304 / 316Ti)

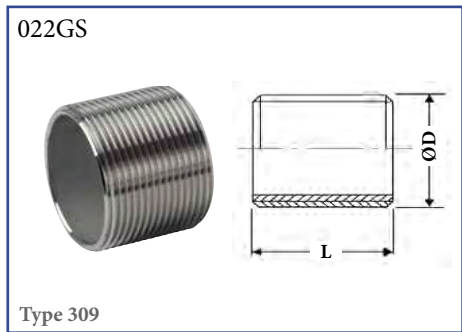

ordering code ⁽²⁾	DN (Inch)	L	Ø D	Kg
------------------------------	-----------	---	-----	----

standardní délka (další viz tabulka níže)

022G-006-316	1/8"	30	10,2	0,02
022G-008-316	1/4"	30	13,5	0,02
022G-010-316	3/8"	30	17,2	0,03
022G-015-316	1/2"	35	21,3	0,04
022G-020-316	3/4"	40	26,9	0,07
022G-025-316	1"	40	33,7	0,10
022G-032-316	1 1/4"	50	42,4	0,17
022G-040-316	1 1/2"	50	48,3	0,21
022G-050-316	2"	50	60,3	0,28
022G-065-316	2 1/2"	60	76,1	0,52
022G-080-316	3"	70	88,9	0,79
022G-100-316	4"	80	114,3	0,82
022G-125-316	5"	*	139,7	*
022G-100-316	6"	*	168,3	*

ordering code ⁽²⁾	DN (Inch)	L	Ø D
------------------------------	-----------	---	-----

022GG-006-X*-316	1/8"		10,2
022GG-008-X*-316	1/4"		13,5
022GG-010-X*-316	3/8"		17,2
022GG-015-X*-316	1/2"		21,3
022GG-020-X*-316	3/4"		26,9
022GG-025-X*-316	1"		33,7
022GG-032-X*-316	1 1/4"		42,4
022GG-040-X*-316	1 1/2"		48,3
022GG-050-X*-316	2"		60,3
022GG-065-X*-316	2 1/2"		76,1
022GG-080-X*-316	3"		88,9
022GG-100-X*-316	4"		114,3

see table below

ordering code ⁽²⁾	DN (Inch)	L	Ø D	Kg
------------------------------	-----------	---	-----	----

022GS-006-316	1/8"		10,2	0,01
022GS-008-316	1/4"		13,5	0,01
022GS-010-316	3/8"		17,2	0,02
022GS-015-316	1/2"		21,3	0,03
022GS-020-316	3/4"		26,9	0,05
022GS-025-316	1"		33,7	0,09
022GS-032-316	1 1/4"		42,4	0,13
022GS-040-316	1 1/2"		48,3	0,16
022GS-050-316	2"		60,3	0,18
022GS-065-316	2 1/2"		76,1	*
022GS-080-316	3"		88,9	*
022GS-100-316	4"		114,3	*

see table below

ordering code ⁽²⁾	DN (Inch)	022G - length of welding nipple (L)																									
022G-008-X*-316	1/4"	40	50	60	80	100	120	150	170	180	190	200	210	220	230	240	250	260	270	280	290	300					
022G-010-X*-316	3/8"	40	50	60	80	100	110	120	150	170	180	190	200	210	220	230	240	250	260			290	300				
022G-015-X*-316	1/2"	40	50	60	80	100	110	120	150		180	200	210	220	230	240	250	260	270	280	290	300					
022G-020-X*-316	3/4"		50	60	80	100	120		150	160	170	180	190	200	210	220	230	240	250	260	270	280	290	300			
022G-025-X*-316	1"		50	60	80	100	120	140	150	160	170	180	190	200	210	220			250	260	270	280	290	300			
022G-032-X*-316	1 1/4"			60	70	80	100	120	150		180		200			230	240	250	260	270	280	290	300				
022G-040-X*-316	1 1/2"			60	80	100	120	150	170	180	190	200	210	220	230	240	250	260	270	280	290	300					
022G-050-X*-316	2"			60	80	100	120	150	170	180	190	200	210	220	230	240	250	260	270	280	290	300					

More dimensions on request

ordering code ⁽²⁾	DN (Inch)	022GG - length of barrel nipple (L)																									
022GG-006-X*-316	1/8"		40																								
022GG-008-X*-316	1/4"	30	40	50	60	70	80	90	100	110	120	140	150	160	170	180	200	220									
022GG-010-X*-316	3/8"		40	50	60	70	80	90	100	110	120	130	140	150	160	170	180	200	220	250							
022GG-015-X*-316	1/2"	30	40	50	60	70	80	90	100	110	120	130	140	150	160	170	180	200	220	250		300					
022GG-020-X*-316	3/4"		40	50	60	70	80	90	100	110	120	130	140	150	160	170	180	200	220	250		300					
022GG-025-X*-316	1"		40	50	60	70	80	90	100	110	120	130		150	160	170	180	200	220	250		300					
022GG-032-X*-316	1 1/4"			50	60	70	80	90	100	110	120	130	140	150	160	170	180	200	220	250		300					
022GG-040-X*-316	1 1/2"			50	60	70	80	90	100	110	120	130	140	150	160	170	180	200	220	250	260	280	290	300			
022GG-050-X*-316	2"			60	80	90	100	110	120	130	140	150	160	170	180	200	220	250					300				
022GG-065-X*-316	2 1/2"							100											200								
022GG-080-X*-316	3"								120											200							
022GG-100-X*-316	4"								120											200							
022GG-125-X*-316	5"												150														
022GG-150-X*-316	6"												150														

More dimensions on request

- (1) on request we can manufacture with outside thread G - parallel
- (2) end marking in code -316 use for stainless steel AISI 316 (for material AISI 304 mark -304 for AISI 316Ti -316Ti)
- * values on demand
- X* length value put instead of X* (e.g. 022G-008-050-316: 022G dimension DN 1/4" with length 50 mm)

THREADED FITTINGS BSP (150 lbs)

Socket
inner thread parallel ISO 228-1G
material: AISI 316 ⁽²⁾ (materiál AISI 304, 316Ti on request)

023G

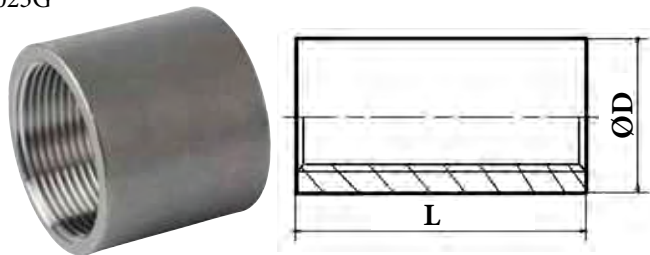

Type 333

Socket short
inner thread parallel ISO 228-1G
material: AISI 316 ⁽²⁾ (material AISI 304, 316Ti on request)

023GS

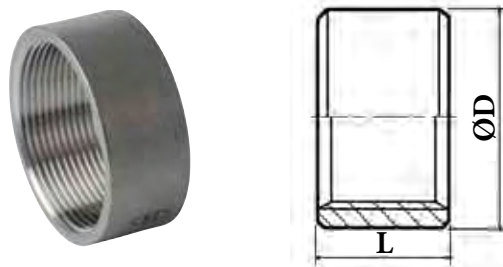

type 334

ordering code ⁽²⁾	DN (Inch)	Ø D (vnější)	L (délka)	Kg
023G-006-316	1/8"	16,0	18,0	0,02
023G-008-316	1/4"	19,5	26,0	0,03
023G-010-316	3/8"	22,0	26,5	0,04
023G-015-316	1/2"	27,7	34,0	0,07
023G-020-316	3/4"	33,6	36,0	0,09
023G-025-316	1"	37,5	43,0	0,14
023G-032-316	1 1/4"	46,5	48,0	0,21
023G-040-316	1 1/2"	53,0	48,0	0,24
023G-050-316	2"	65,5	56,0	0,36
023G-065-316	2 1/2"	82,0	63,0	0,50
023G-080-316	3"	95,5	71,0	0,72
023G-100-316	4"	121,5	83,0	1,20
023G-125-316	5"	*	*	*
023G-100-316	6"	*	*	*

ordering code ⁽²⁾	DN (Inch)	Kg
023GS-006-316	1/8"	0,01
023GS-008-316	1/4"	0,02
023GS-010-316	3/8"	0,03
023GS-015-316	1/2"	0,04
023GS-020-316	3/4"	0,05
023GS-025-316	1"	0,06
023GS-032-316	1 1/4"	0,10
023GS-040-316	1 1/2"	0,12
023GS-050-316	2"	0,18
023GS-065-316	2 1/2"	0,25
023GS-080-316	3"	0,36
023GS-100-316	4"	0,60
023GS-125-316	5"	*
023GS-100-316	6"	*

(2) end marking in code -316 use for stainless steel AISI 316 (for material AISI 304 mark -304 for AISI 316Ti -316Ti)
* not specified dimensions and weights on demand

THREADED FITTINGS BSP (150 lbs)

Hexagon nipple
outside threads taper ISO 7-1R
material: AISI 316 (304)

021G

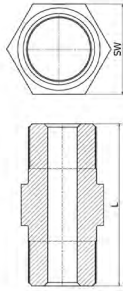

Type 340

Hexagon nipple with parallel thread
outside threads parallel ISO 228-1G
material: AISI 316 (AISI 304)

021GP

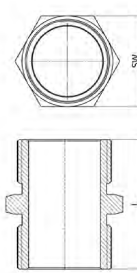

Hexagon nipple reducing
outside threads taper ISO 7-1R
material: AISI 316 (304)

021GR

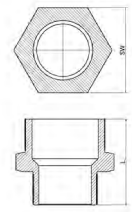

Type 341

ordering code ⁽²⁾	DN (Inch)	L (délka)	Kg
021G-006-316	1/8"	*	0,01
021G-008-316	1/4"	*	0,02
021G-010-316	3/8"	*	0,03
021G-015-316	1/2"	*	0,05
021G-020-316	3/4"	*	0,08
021G-025-316	1"	*	0,12
021G-032-316	1 1/4"	*	0,23
021G-040-316	1 1/2"	*	0,26
021G-050-316	2"	*	0,40
021G-065-316	2 1/2"	*	0,72
021G-080-316	3"	*	0,88
021G-100-316	4"	*	1,46

ordering code ⁽²⁾	DN (Inch)	L (délka)	Kg
021GP-006-316	1/8"	*	0,01
021GP-008-316	1/4"	*	0,02
021GP-010-316	3/8"	*	0,03
021GP-015-316	1/2"	*	0,05
021GP-020-316	3/4"	*	0,08
021GP-025-316	1"	*	0,12
021GP-032-316	1 1/4"	*	0,23
021GP-040-316	1 1/2"	*	0,26
021GP-050-316	2"	*	0,40
021GP-065-316	2 1/2"	*	0,72
021GP-080-316	3"	*	0,88
021GP-100-316	4"	*	1,46

ordering code ⁽²⁾	DN (Inch)	Kg
021GR-008-006-316	1/4" x 1/8"	0,03
021GR-010-006-316	3/8" x 1/8"	0,04
021GR-010-008-316	3/8" x 1/4"	0,04
021GR-015-006-316	1/2" x 1/8"	0,05
021GR-015-008-316	1/2" x 1/4"	0,05
021GR-015-010-316	1/2" x 3/8"	0,07
021GR-020-006-316	3/4" x 1/8"	0,07
021GR-020-008-316	3/4" x 1/4"	0,08
021GR-020-010-316	3/4" x 3/8"	0,08
021GR-020-015-316	3/4" x 1/2"	0,10
021GR-025-006-316	1" x 1/8"	0,10
021GR-025-008-316	1" x 1/4"	0,10
021GR-025-010-316	1" x 3/8"	0,10
021GR-025-015-316	1" x 1/2"	0,12
021GR-025-020-316	1" x 3/4"	0,15
021GR-032-015-316	1 1/4" x 1/2"	0,21
021GR-032-020-316	1 1/4" x 3/4"	0,21
021GR-032-025-316	1 1/4" x 1"	0,22
021GR-040-010-316	1 1/2" x 3/8"	0,24
021GR-040-015-316	1 1/2" x 1/2"	0,24
021GR-040-020-316	1 1/2" x 3/4"	0,25
021GR-040-025-316	1 1/2" x 1"	0,27
021GR-040-032-316	1 1/2" x 1 1/4"	0,31
021GR-050-015-316	2" x 1/2"	0,34
021GR-050-020-316	2" x 3/4"	0,34
021GR-050-025-316	2" x 1"	0,34
021GR-050-032-316	2" x 1 1/4"	0,37
021GR-050-040-316	2" x 1 1/2"	0,43
021GR-065-020-316	2 1/2" x 3/4"	0,70
021GR-065-025-316	2 1/2" x 1"	0,70
021GR-065-032-316	2 1/2" x 1 1/4"	0,74
021GR-065-040-316	2 1/2" x 1 1/2"	0,74
021GR-065-050-316	2 1/2" x 2"	0,94
021GR-080-025-316	3" x 1"	1,08
021GR-080-032-316	3" x 1 1/4"	1,08
021GR-080-040-316	3" x 1 1/2"	1,08
021GR-080-050-316	3" x 2"	1,03
021GR-080-065-316	3" x 2 1/2"	1,36
021GR-100-040-316	4" x 1 1/2"	0,75
021GR-100-050-316	4" x 2"	0,75
021GR-100-065-316	4" x 2 1/2"	1,58
021GR-100-080-316	4" x 3"	2,14

Elbow 90° - M/M
outside threads taper ISO 7-1R
material: AISI 316

031GMM

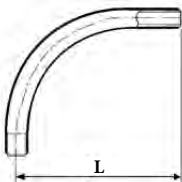

ordering code ⁽²⁾	DN (Inch)	Kg
031GMM-006-316	1/8"	0,05
031GMM-008-316	1/4"	0,07
031GMM-010-316	3/8"	0,09
031GMM-015-316	1/2"	0,18
031GMM-020-316	3/4"	0,30
031GMM-025-316	1"	0,54
031GMM-032-316	1 1/4"	0,83
031GMM-040-316	1 1/2"	1,13
031GMM-050-316	2"	1,88
031GMM-065-316	2 1/2"	*
031GMM-080-316	3"	*

(2) end marking in code -316 use for stainless steel AISI 316 (for material AISI 304 mark -304)
* not specified dimensions and weights on demand

THREADED FITTINGS BSP (150 lbs)

Elbow 45° - F/F
inner threads parallel ISO 228-1G
material: AISI 316 (304)

031G45

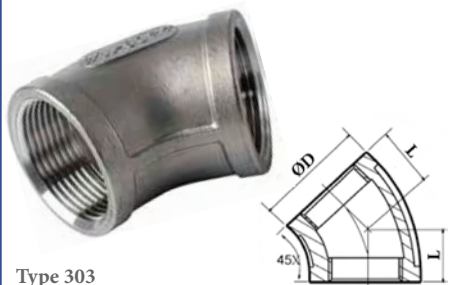

Type 303

ordering code ⁽²⁾	DN (Inch)	Kg
031G45-006-316	1/8"	0,02
031G45-008-316	1/4"	0,03
031G45-010-316	3/8"	0,04
031G45-015-316	1/2"	0,06
031G45-020-316	3/4"	0,09
031G45-025-316	1"	0,15
031G45-032-316	1 1/4"	0,24
031G45-040-316	1 1/2"	0,31
031G45-050-316	2"	0,48
031G45-065-316	2 1/2"	0,86
031G45-080-316	3"	1,19
031G45-100-316	4"	2,00

Elbow 45° - M/F
outside thread R / inner thread G
material: AISI 316 (304)

031G45MF

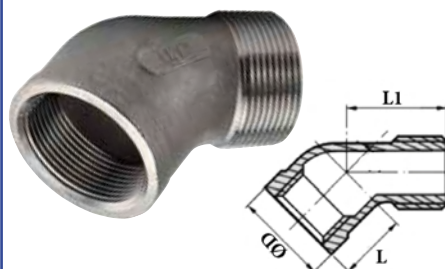

ordering code ⁽²⁾	DN (Inch)	Kg
031G45MF-006-316	1/8"	0,02
031G45MF-008-316	1/4"	0,04
031G45MF-010-316	3/8"	0,06
031G45MF-015-316	1/2"	0,09
031G45MF-020-316	3/4"	0,14
031G45MF-025-316	1"	0,23
031G45MF-032-316	1 1/4"	0,36
031G45MF-040-316	1 1/2"	0,42
031G45MF-050-316	2"	0,70
031G45MF-065-316	2 1/2"	1,00
031G45MF-080-316	3"	1,30
031G45MF-100-316	4"	1,60

Elbow with bar - F/F
inner threads parallel ISO 228-1G
material: AISI 316 (304)

031GB

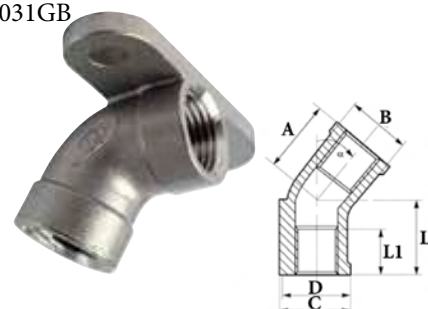

ordering code ⁽²⁾	DN (Inch)	Úhel	Kg
031GB-015-045-316	1/2"	45°	0,10
031GB-015-060-316	1/2"	60°	0,10
031GB-015-075-316	1/2"	75°	0,10
031GB-015-090-316	1/2"	90°	0,10

Elbow 90° reducing - F/F
inner threads parallel ISO 228-1G
material: AISI 316 (304)

031GR

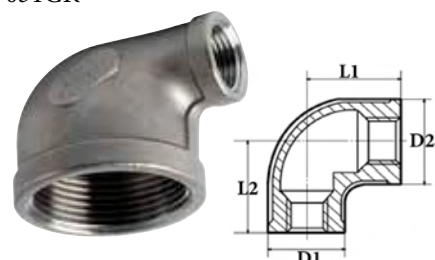

Type 301R

ordering code ⁽²⁾	DN (Inch)	Kg
031GR-008-006-316	1/4" x 1/8"	0,04
031GR-010-006-316	3/8" x 1/8"	0,04
031GR-010-008-316	3/8" x 1/4"	0,06
031GR-015-006-316	1/2" x 1/8"	0,08
031GR-015-008-316	1/2" x 1/4"	0,08
031GR-015-010-316	1/2" x 3/8"	0,09
031GR-020-008-316	3/4" x 1/4"	0,11
031GR-020-010-316	3/4" x 3/8"	0,12
031GR-020-015-316	3/4" x 1/2"	0,13
031GR-025-008-316	1" x 1/4"	0,18
031GR-025-010-316	1" x 3/8"	0,19
031GR-025-015-316	1" x 1/2"	0,20
031GR-025-020-316	1" x 3/4"	0,22
031GR-032-010-316	1 1/4" x 3/8"	0,26
031GR-032-015-316	1 1/4" x 1/2"	0,28
031GR-032-020-316	1 1/4" x 3/4"	0,32
031GR-032-025-316	1 1/4" x 1"	0,35
031GR-040-010-316	1 1/2" x 3/8"	0,33
031GR-040-015-316	1 1/2" x 1/2"	0,34
031GR-040-020-316	1 1/2" x 3/4"	0,36
031GR-040-025-316	1 1/2" x 1"	0,39
031GR-040-032-316	1 1/2" x 1 1/4"	0,45
031GR-050-015-316	2" x 1/2"	0,48
031GR-050-020-316	2" x 3/4"	0,52
031GR-050-025-316	2" x 1"	0,56
031GR-050-032-316	2" x 1 1/4"	0,66
031GR-050-040-316	2" x 1 1/2"	0,72

Elbow 90° - F/F
inner threads parallel ISO 228-1G
material: AISI 316 (304)

031G

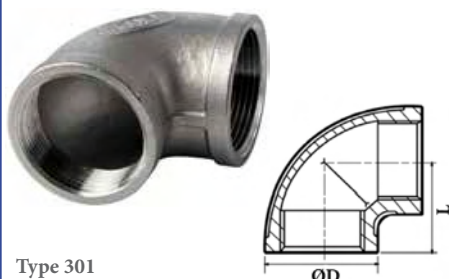

Type 301

ordering code ⁽²⁾	DN (Inch)	Kg
031G-006-316	1/8"	0,02
031G-008-316	1/4"	0,03
031G-010-316	3/8"	0,05
031G-015-316	1/2"	0,07
031G-020-316	3/4"	0,11
031G-025-316	1"	0,18
031G-032-316	1 1/4"	0,30
031G-040-316	1 1/2"	0,37
031G-050-316	2"	0,63
031G-065-316	2 1/2"	1,07
031G-080-316	3"	1,53
031G-100-316	4"	2,65

Elbow 90° - M/F
outside thread R / inner thread G
material: AISI 316 (304)

031GMF

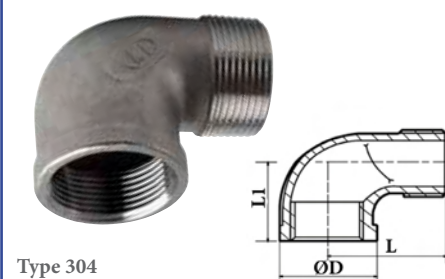

Type 304

ordering code ⁽²⁾	DN (Inch)	Kg
031GMF-006-316	1/8"	0,02
031GMF-008-316	1/4"	0,03
031GMF-010-316	3/8"	0,04
031GMF-015-316	1/2"	0,07
031GMF-020-316	3/4"	0,10
031GMF-025-316	1"	0,18
031GMF-032-316	1 1/4"	0,27
031GMF-040-316	1 1/2"	0,38
031GMF-050-316	2"	0,62
031GMF-065-316	2 1/2"	1,05
031GMF-080-316	3"	1,90
031GMF-100-316	4"	2,80

(2) end marking in code -316 use for stainless steel AISI 316 (for material AISI 304 mark -304)
* not specified dimensions and weights on demand

THREADED FITTINGS BSP (150 lbs)

Hexagon cap
inner thread parallel ISO 228-1G
material: AISI 316 (304)

024G

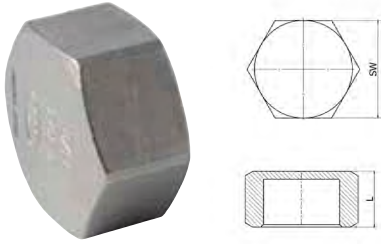

Type 326

Round cap
inner thread parallel ISO 228-1G
material: AISI 316 (AISI 304)

024G2

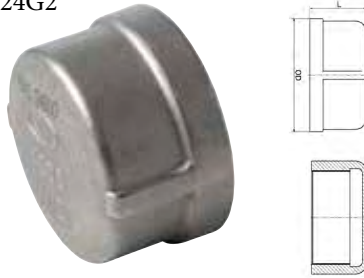

Hexagon nut
inner thread parallel ISO 228-1G
material: AISI 316

024G3

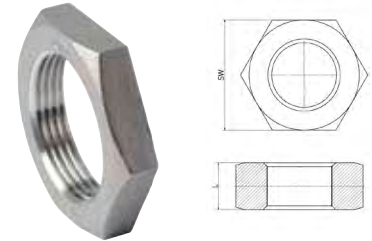

Type 327

ordering code ⁽²⁾	DN (Inch)	Kg
024G-006-316	1/8"	0,02
024G-008-316	1/4"	0,03
024G-010-316	3/8"	0,03
024G-015-316	1/2"	0,06
024G-020-316	3/4"	0,07
024G-025-316	1"	0,12
024G-032-316	1 1/4"	0,23
024G-040-316	1 1/2"	0,25
024G-050-316	2"	0,49
024G-065-316	2 1/2"	1,08
024G-080-316	3"	1,77
024G-100-316	4"	2,58

ordering code ⁽²⁾	DN (Inch)	Kg
024G2-006-316	1/8"	0,02
024G2-008-316	1/4"	0,03
024G2-010-316	3/8"	0,03
024G2-015-316	1/2"	0,04
024G2-020-316	3/4"	0,08
024G2-025-316	1"	0,13
024G2-032-316	1 1/4"	0,22
024G2-040-316	1 1/2"	0,28
024G2-050-316	2"	0,39
024G2-065-316	2 1/2"	0,92
024G2-080-316	3"	1,02
024G2-100-316	4"	2,00

ordering code	DN (Inch)	Kg
024G3-006-316	1/8"	0,01
024G3-008-316	1/4"	0,01
024G3-010-316	3/8"	0,02
024G3-015-316	1/2"	0,02
024G3-020-316	3/4"	0,03
024G3-025-316	1"	0,07
024G3-032-316	1 1/4"	0,08
024G3-040-316	1 1/2"	0,13
024G3-050-316	2"	0,22
024G3-065-316	2 1/2"	0,25
024G3-080-316	3"	0,51
024G3-100-316	4"	0,74

Hexagon head plug tapered
outside threads taper ISO 7-1R
material: AISI 316 (304)

025G

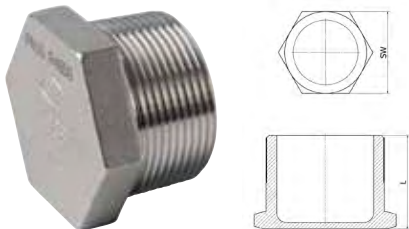

Type 330

Hexagon head plug parallel
outside thread parallel ISO 228-1G
material: AISI 316

025GP

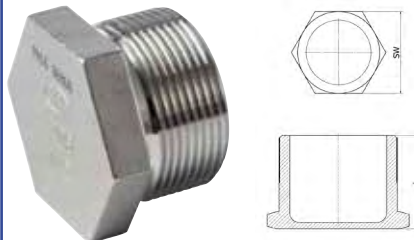

Square head plug
outside threads taper ISO 7-1R
material: AISI 316 (304)

025G2



Type 329

ordering code ⁽²⁾	DN (Inch)	Kg
025G-006-316	1/8"	0,01
025G-008-316	1/4"	0,02
025G-010-316	3/8"	0,04
025G-015-316	1/2"	0,05
025G-020-316	3/4"	0,07
025G-025-316	1"	0,12
025G-032-316	1 1/4"	0,21
025G-040-316	1 1/2"	0,30
025G-050-316	2"	0,44
025G-065-316	2 1/2"	0,71
025G-080-316	3"	1,11
025G-100-316	4"	1,98

ordering code	DN (Inch)	Kg
025GP-006-316	1/8"	0,01
025GP-008-316	1/4"	0,02
025GP-010-316	3/8"	0,04
025GP-015-316	1/2"	0,05
025GP-020-316	3/4"	0,07
025GP-025-316	1"	0,12
025GP-032-316	1 1/4"	0,21
025GP-040-316	1 1/2"	0,30
025GP-050-316	2"	0,44
025GP-065-316	2 1/2"	0,71
025GP-080-316	3"	1,11
025GP-100-316	4"	1,98

ordering code ⁽²⁾	DN (Inch)	Kg
025G2-006-316	1/8"	0,01
025G2-008-316	1/4"	0,02
025G2-010-316	3/8"	0,04
025G2-015-316	1/2"	0,05
025G2-020-316	3/4"	0,07
025G2-025-316	1"	0,12
025G2-032-316	1 1/4"	0,22
025G2-040-316	1 1/2"	0,30
025G2-050-316	2"	0,44
025G2-065-316	2 1/2"	0,71
025G2-080-316	3"	1,11
025G2-100-316	4"	1,98

(2) end marking in code -316 use for stainless steel AISI 316 (for material AISI 304 mark -304)
* not specified dimensions and weights on demand

THREADED FITTINGS BSP (150 lbs)

Hexagon hose nipple M
outside threads taper ISO 7-1R
material: AISI 316

026G

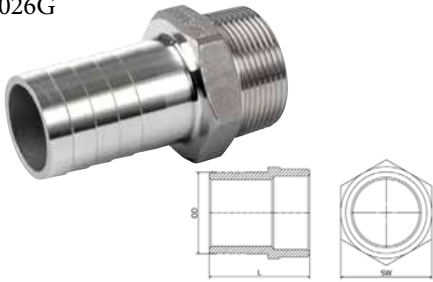

Type 337

Hexagon hose nipple F
inner thread parallel ISO 228-1G
material: AISI 316

026GF

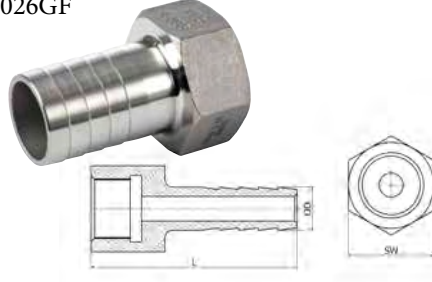

Pipe hose nipple M
outside threads taper ISO 7-1R
material: AISI 316

026GM

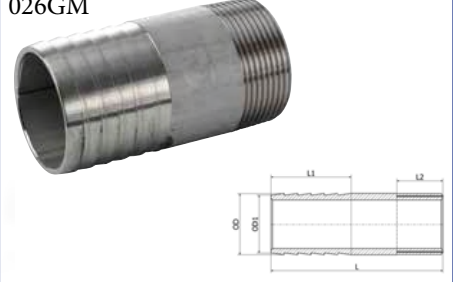

Type 337G

ordering code	DN (Inch)	Ø D	Kg
026G-006-006-316	1/8"	6	0,02
026G-006-007-316	1/8"	7	0,02
026G-008-006-316	1/4"	6,3	0,03
026G-008-008-316	1/4"	8	0,03
026G-008-009-316	1/4"	9	0,03
026G-008-010-316	1/4"	10	0,03
026G-008-011-316	1/4"	11	0,03
026G-008-012-316	1/4"	12,7	0,03
026G-008-013-316	1/4"	13	0,03
026G-010-006-316	3/8"	6,3	0,04
026G-010-008-316	3/8"	8	0,04
026G-010-009-316	3/8"	9,5	0,04
026G-010-010-316	3/8"	10	0,04
026G-010-011-316	3/8"	11	0,04
026G-010-012-316	3/8"	12,7	0,04
026G-010-013-316	3/8"	15	0,04
026G-015-006-316	1/2"	6,3	0,07
026G-015-009-316	1/2"	9	0,07
026G-015-010-316	1/2"	10	0,07
026G-015-011-316	1/2"	11	0,07
026G-015-012-316	1/2"	12,7	0,07
026G-015-014-316	1/2"	14	0,07
026G-015-019-316	1/2"	19	0,07
026G-020-012-316	3/4"	12,7	0,14
026G-020-016-316	3/4"	16	0,14
026G-020-019-316	3/4"	19	0,14
026G-020-020-316	3/4"	20,5	0,14
026G-020-025-316	3/4"	25,4	0,14
026G-025-012-316	1"	12,7	0,24
026G-025-019-316	1"	19	0,24
026G-025-020-316	1"	20	0,24
026G-025-025-316	1"	25,4	0,24
026G-025-027-316	1"	27	0,24
026G-032-031-316	1 1/4"	31,8	0,27
026G-032-033-316	1 1/4"	33	0,27
026G-032-038-316	1 1/4"	38	0,27
026G-040-038-316	1 1/2"	38	0,41
026G-040-038-316	1 1/2"	39,5	0,41
026G-050-050-316	2"	50,8	0,69
026G-050-052-316	2"	52	0,69
026G-065-063-316	2 1/2"	63,5	1,06
026G-065-067-316	2 1/2"	67	1,06
026G-080-076-316	3"	76,1	1,41
026G-080-080-316	3"	80	1,41
026G-100-101-316	4"	101,6	2,98
026G-100-105-316	4"	105	2,98

ordering code	DN (Inch)	Ø D	Kg
026GF-006-006-316	1/8"	6,3	0,02
026GF-008-006-316	1/4"	6,3	0,04
026GF-008-009-316	1/4"	9	0,04
026GF-010-009-316	3/8"	9,5	0,06
026GF-010-011-316	3/8"	11	0,06
026GF-015-012-316	1/2"	12,7	0,09
026GF-015-014-316	1/2"	14	0,09
026GF-020-019-316	3/4"	19	0,12
026GF-020-020-316	3/4"	20,5	0,12
026GF-025-025-316	1"	25,4	0,19
026GF-025-027-316	1"	27	0,19
026GF-032-031-316	1 1/4"	31,8	0,32
026GF-032-033-316	1 1/4"	33	0,32
026GF-040-038-316	1 1/2"	38,1	0,39
026GF-040-039-316	1 1/2"	39,5	0,39
026GF-050-050-316	2"	50,8	0,65
026GF-050-052-316	2"	52	0,65

ordering code	DN (Inch)	Ø D	Kg
026GM-006-316	1/8"	10,2	0,04
026GM-008-316	1/4"	13,5	0,04
026GM-010-316	3/8"	17,2	0,06
026GM-015-316	1/2"	21,3	0,10
026GM-020-316	3/4"	26,7	0,12
026GM-025-316	1"	33,4	0,19
026GM-032-316	1 1/4"	42,2	0,29
026GM-040-316	1 1/2"	48,3	0,34
026GM-050-316	2"	60,3	0,49
026GM-065-316	2 1/2"	76,1	0,85
026GM-080-316	3"	88,9	1,16
026GM-100-316	4"	114,3	1,73

Pipe hose nipple W
welding end
material: DIN 1.4301 (1.4404)

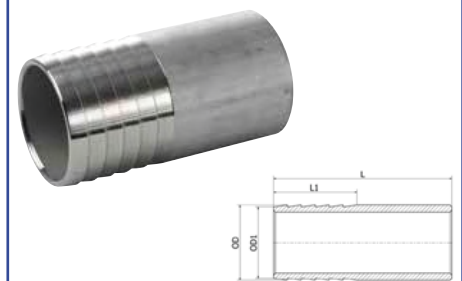

Type 337S

ordering code ⁽³⁾	Ø D	L	Kg
140L-013-1.4301	13	31	0,03
140L-016-1.4301	16	45	0,03
140L-017-1.4301	17,2	45	0,04
140L-019-1.4301	19	45	0,05
140L-021-1.4301	21,3	50	0,10
140L-026-1.4301	26,9	60	0,12
140L-032-1.4301	32	60	0,17
140L-033-1.4301	33,7	65	0,19
140L-038-1.4301	38	65	0,20
140L-040-1.4301	40	75	0,25
140L-042-1.4301	42,4	75	0,25
140L-048-1.4301	48,3	75	0,30
140L-052-1.4301	52	80	0,30
140L-060-1.4301	60,3	100	0,35
140L-063-1.4301	63	100	0,35
140L-076-1.4301	76,1	120	0,40
140L-080-1.4301	80	120	0,40
140L-088-1.4301	88,9	120	0,45
140L-101-1.4301	101	120	0,50
140L-114-1.4301	114,3	120	0,50

(2) end marking in code -316 use for stainless steel AISI 316 (for material AISI 304 mark -304)
(3) end marking in code -1.4301 for stainless steel DIN 1.4301 (-1.4404 = DIN 1.4404)
* not specified dimensions and weights on demand

THREADED FITTINGS BSP (150 lbs)

Hexagon reducing bushing (M/F)
outside thread R / inner thread G
material: AISI 316 (304)

027G



Type 325

Threaded reducing socket (F/F)
inner thread parallel ISO 228-1G
material: AISI 316

027GFF



Type 335

Hexagon negative reducing bushing (F/M)
inner thread G / outside thread R
material: AISI 316

028G

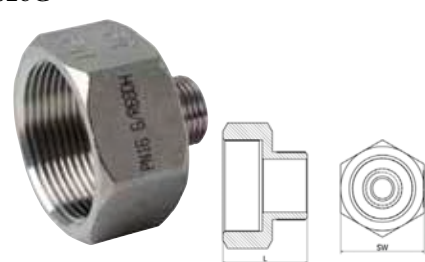

ordering code ⁽²⁾	DN 1 (M)	DN 2 (F)	Kg
027G-008-006-316	1/4"	1/8"	0,01
027G-010-006-316	3/8"	1/8"	0,02
027G-010-008-316	3/8"	1/4"	0,01
027G-015-006-316	1/2"	1/8"	0,04
027G-015-008-316	1/2"	1/4"	0,04
027G-015-010-316	1/2"	3/8"	0,03
027G-020-006-316	3/4"	1/8"	0,07
027G-020-008-316	3/4"	1/4"	0,07
027G-020-010-316	3/4"	3/8"	0,06
027G-020-015-316	3/4"	1/2"	0,05
027G-025-008-316	1"	1/4"	0,10
027G-025-010-316	1"	3/8"	0,10
027G-025-015-316	1"	1/2"	0,10
027G-025-020-316	1"	3/4"	0,08
027G-032-015-316	1 1/4"	1/2"	0,17
027G-032-020-316	1 1/4"	3/4"	0,17
027G-032-025-316	1 1/4"	1"	0,14
027G-040-010-316	1 1/2"	3/8"	0,27
027G-040-015-316	1 1/2"	1/2"	0,27
027G-040-020-316	1 1/2"	3/4"	0,27
027G-040-025-316	1 1/2"	1"	0,27
027G-040-032-316	1 1/2"	1 1/4"	0,20
027G-050-015-316	2"	1/2"	0,35
027G-050-020-316	2"	3/4"	0,35
027G-050-025-316	2"	1"	0,35
027G-050-032-316	2"	1 1/4"	0,36
027G-050-040-316	2"	1 1/2"	0,38
027G-065-025-316	2 1/2"	1"	0,75
027G-065-040-316	2 1/2"	1 1/2"	0,65
027G-065-050-316	2 1/2"	2"	0,55
027G-080-040-316	3"	1 1/2"	1,12
027G-080-050-316	3"	2"	1,00
027G-080-065-316	3"	2 1/2"	0,84
027G-100-050-316	4"	2"	1,97
027G-100-065-316	4"	2 1/2"	1,63
027G-100-080-316	4"	3"	1,49

ordering code	DN 1 (Inch)	DN 2 (Inch)	Kg
027GFF-008-006-316	1/4"	1/8"	0,03
027GFF-010-006-316	3/8"	1/8"	0,05
027GFF-010-008-316	3/8"	1/4"	0,05
027GFF-015-006-316	1/2"	1/8"	0,06
027GFF-015-008-316	1/2"	1/4"	0,08
027GFF-015-010-316	1/2"	3/8"	0,07
027GFF-020-008-316	3/4"	1/4"	0,10
027GFF-020-010-316	3/4"	3/8"	0,10
027GFF-020-015-316	3/4"	1/2"	0,12
027GFF-025-008-316	1"	1/4"	0,15
027GFF-025-010-316	1"	3/8"	0,15
027GFF-025-015-316	1"	1/2"	0,15
027GFF-025-020-316	1"	3/4"	0,15
027GFF-032-015-316	1 1/4"	1/2"	0,23
027GFF-032-020-316	1 1/4"	3/4"	0,23
027GFF-032-025-316	1 1/4"	1"	0,23
027GFF-040-010-316	1 1/2"	3/8"	0,29
027GFF-040-015-316	1 1/2"	1/2"	0,29
027GFF-040-020-316	1 1/2"	3/4"	0,28
027GFF-040-025-316	1 1/2"	1"	0,28
027GFF-040-032-316	1 1/2"	1 1/4"	0,28
027GFF-050-015-316	2"	1/2"	0,38
027GFF-050-020-316	2"	3/4"	0,38
027GFF-050-025-316	2"	1"	0,46
027GFF-050-032-316	2"	1 1/4"	0,45
027GFF-050-040-316	2"	1 1/2"	0,45
027GFF-065-025-316	2 1/2"	1"	0,73
027GFF-065-032-316	2 1/2"	1 1/4"	0,70
027GFF-065-040-316	2 1/2"	1 1/2"	0,70
027GFF-065-050-316	2 1/2"	2"	0,65
027GFF-080-040-316	3"	1 1/2"	0,72
027GFF-080-050-316	3"	2"	0,70
027GFF-080-065-316	3"	2 1/2"	0,70
027GFF-100-050-316	4"	2"	1,31
027GFF-100-065-316	4"	2 1/2"	1,29
027GFF-100-080-316	4"	3"	0,94

ordering code	DN 1 (F)	DN 2 (M)	Kg
028G-008-006-316	1/4"	1/8"	0,01
028G-010-006-316	3/8"	1/8"	0,02
028G-010-008-316	3/8"	1/4"	0,01
028G-015-006-316	1/2"	1/8"	0,04
028G-015-008-316	1/2"	1/4"	0,04
028G-015-010-316	1/2"	3/8"	0,03
028G-020-006-316	3/4"	1/8"	0,08
028G-020-008-316	3/4"	1/4"	0,07
028G-020-010-316	3/4"	3/8"	0,06
028G-020-015-316	3/4"	1/2"	0,05
028G-025-006-316	1"	1/8"	0,11
028G-025-008-316	1"	1/4"	0,11
028G-025-010-316	1"	3/8"	0,10
028G-025-015-316	1"	1/2"	0,10
028G-025-020-316	1"	3/4"	0,08
028G-032-008-316	1 1/4"	1/4"	0,19
028G-032-010-316	1 1/4"	3/8"	0,19
028G-032-015-316	1 1/4"	1/2"	0,19
028G-032-020-316	1 1/4"	3/4"	0,17
028G-032-025-316	1 1/4"	1"	0,14
028G-040-008-316	1 1/2"	1/4"	0,31
028G-040-010-316	1 1/2"	3/8"	0,31
028G-040-015-316	1 1/2"	1/2"	0,31
028G-040-020-316	1 1/2"	3/4"	0,31
028G-040-025-316	1 1/2"	1"	0,27
028G-040-032-316	1 1/2"	1 1/4"	0,20
028G-050-008-316	2"	1/4"	0,45
028G-050-010-316	2"	3/8"	0,43
028G-050-015-316	2"	1/2"	0,41
028G-050-020-316	2"	3/4"	0,37
028G-050-025-316	2"	1"	0,35
028G-050-032-316	2"	1 1/4"	0,35
028G-050-040-316	2"	1 1/2"	0,30

(2) end marking in code -316 use for stainless steel AISI 316 (for material AISI 304 mark -304)
* not specified dimensions and weights on demand

THREADED FITTINGS BSP (150 lbs)

Equal T-piece F/F/F
inner threads parallel ISO 228-1G
material: AISI 316 (304)

032G

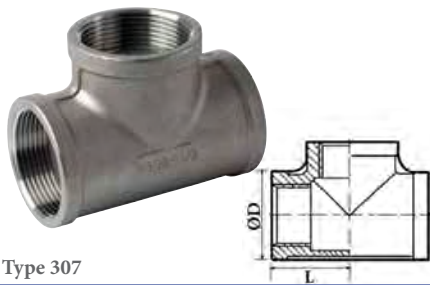

Type 307

ordering code ⁽²⁾	DN (Inch)	Kg
032G-006-316	1/8"	0,03
032G-008-316	1/4"	0,04
032G-010-316	3/8"	0,06
032G-015-316	1/2"	0,10
032G-020-316	3/4"	0,14
032G-025-316	1"	0,24
032G-032-316	1 1/4"	0,38
032G-040-316	1 1/2"	0,48
032G-050-316	2"	0,79
032G-065-316	2 1/2"	1,37
032G-080-316	3"	1,83
032G-100-316	4"	3,15

Cross
inner threads parallel ISO 228-1G
material: AISI 316

032GK

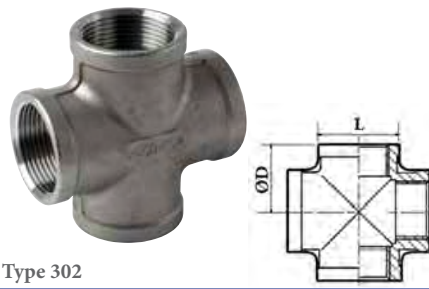

Type 302

ordering code ⁽²⁾	DN (Inch)	Kg
032GK-006-316	1/8"	0,04
032GK-008-316	1/4"	0,05
032GK-010-316	3/8"	0,08
032GK-015-316	1/2"	0,12
032GK-020-316	3/4"	0,18
032GK-025-316	1"	0,28
032GK-032-316	1 1/4"	0,46
032GK-040-316	1 1/2"	0,58
032GK-050-316	2"	0,87
032GK-065-316	2 1/2"	1,65
032GK-080-316	3"	2,30
032GK-100-316	4"	3,61

T-piece reducing F/F/F
inner threads parallel ISO 228-1G
material: AISI 316 (304)

032GR

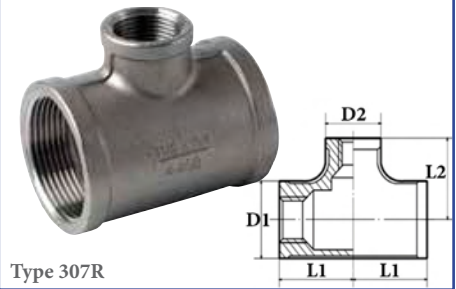

Type 307R

ordering code ⁽²⁾	DN (Inch)	Kg
032GR-008-006-316	1/4" x 1/8"	0,04
032GR-010-006-316	3/8" x 1/8"	0,04
032GR-010-008-316	3/8" x 1/4"	0,06
032GR-015-006-316	1/2" x 1/8"	0,08
032GR-015-008-316	1/2" x 1/4"	0,08
032GR-015-010-316	1/2" x 3/8"	0,09
032GR-020-008-316	3/4" x 1/4"	0,11
032GR-020-010-316	3/4" x 3/8"	0,12
032GR-020-015-316	3/4" x 1/2"	0,13
032GR-025-008-316	1" x 1/4"	0,18
032GR-025-010-316	1" x 3/8"	0,19
032GR-025-015-316	1" x 1/2"	0,20
032GR-025-020-316	1" x 3/4"	0,22
032GR-032-010-316	1 1/4" x 3/8"	0,26
032GR-032-015-316	1 1/4" x 1/2"	0,28
032GR-032-020-316	1 1/4" x 3/4"	0,32
032GR-032-025-316	1 1/4" x 1"	0,35
032GR-040-010-316	1 1/2" x 3/8"	0,33
032GR-040-015-316	1 1/2" x 1/2"	0,34
032GR-040-020-316	1 1/2" x 3/4"	0,36
032GR-040-025-316	1 1/2" x 1"	0,39
032GR-040-032-316	1 1/2" x 1 1/4"	0,45
032GR-050-015-316	2" x 1/2"	0,48
032GR-050-020-316	2" x 3/4"	0,52
032GR-050-025-316	2" x 1"	0,56
032GR-050-032-316	2" x 1 1/4"	0,66
032GR-050-040-316	2" x 1 1/2"	0,72

Y-piece F/F/F
inner threads parallel ISO 228-1G
material: AISI 316

029G



ordering code ⁽²⁾	DN (Inch)	Kg
029G-006-316	1/8"	0,04
029G-008-316	1/4"	0,06
029G-010-316	3/8"	0,10
029G-015-316	1/2"	0,13
029G-020-316	3/4"	0,19
029G-025-316	1"	0,32
029G-032-316	1 1/4"	0,49
029G-040-316	1 1/2"	0,57
029G-050-316	2"	0,89

(2) end marking in code -316 use for stainless steel AISI 316 (for material AISI 304 mark -304)
* not specified dimensions and weights on demand

THREADED FITTINGS BSP (150 lbs)

Threaded adaptor - NPT male / BSP female
outside thread NPT / inner thread parallel ISO 228-1G
material: AISI 316 (DIN 1.4408)

AG027-MF

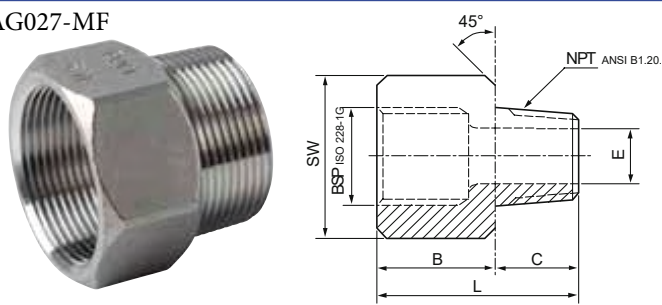

Threaded adaptor - NPT male / BSP female
inner thread NPT / outside thread taper ISO 7-1R
material: AISI 316 (DIN 1.4408)

AG027-FM

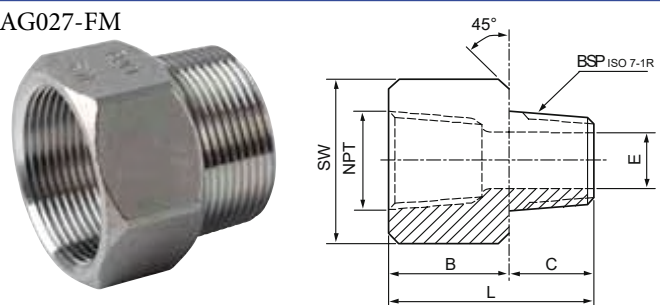

ordering code	DN	L	SW	B	C	E	Kg
AG027MF-006-316	1/8"	26,0	14,5	15,5	10,5	5,0	0,02
AG027MF-008-316	1/4"	28,5	17,0	16,5	12,0	8,0	0,03
AG027MF-010-316	3/8"	31,0	21,0	18,5	12,5	10,0	0,04
AG027MF-015-316	1/2"	37,5	26,0	22,0	15,5	13,5	0,07
AG027MF-020-316	3/4"	41,0	32,0	23,0	18,0	20,0	0,28
AG027MF-025-316	1"	46,0	38,0	26,0	20,0	26,0	0,30
AG027MF-032-316	1 1/4"	49,0	46,0	27,0	22,0	33,0	0,39
AG027MF-040-316	1 1/2"	51,0	54,0	28,0	23,0	39,0	0,40
AG027MF-050-316	2"	55,5	63,0	30,0	25,5	52,0	0,54

ordering code	DN	L	SW	B	C	E	Kg
AG027FM-006-316	1/8"	26,0	14,5	15,5	10,5	5,0	0,02
AG027FM-008-316	1/4"	28,5	17,0	16,5	12,0	8,0	0,03
AG027FM-010-316	3/8"	31,0	21,0	18,5	12,5	10,0	0,04
AG027FM-015-316	1/2"	37,5	26,0	22,0	15,5	13,5	0,07
AG027FM-020-316	3/4"	41,0	32,0	23,0	18,0	20,0	0,28
AG027FM-025-316	1"	46,0	38,0	26,0	20,0	26,0	0,30
AG027FM-032-316	1 1/4"	49,0	46,0	27,0	22,0	33,0	0,39
AG027FM-040-316	1 1/2"	51,0	54,0	28,0	23,0	39,0	0,40
AG027FM-050-316	2"	55,5	63,0	30,0	25,5	52,0	0,54

THREADED FITTINGS BSP (150 lbs)

Union flat - F/F

inner threads parallel ISO 228-1G
material: AISI 316 (AISI 304) gasket PTFE

020GT-FF



Type 311

ordering code ⁽²⁾	DN (Inch)	Kg
020GT-006-FF-316	1/8"	0,06
020GT-008-FF-316	1/4"	0,10
020GT-010-FF-316	3/8"	0,12
020GT-015-FF-316	1/2"	0,20
020GT-020-FF-316	3/4"	0,27
020GT-025-FF-316	1"	0,31
020GT-032-FF-316	1 1/4"	0,72
020GT-040-FF-316	1 1/2"	0,80
020GT-050-FF-316	2"	1,19
020GT-065-FF-316	2 1/2"	1,81
020GT-080-FF-316	3"	2,60
020GT-100-FF-316	4"	4,55

Union flat - M/F

inner thread parallel ISO 228-1G / outside thread ISO 7-1R
material: AISI 316 (AISI 304) gasket PTFE

020GT-MF



Type 311A

ordering code ⁽²⁾	DN (Inch)	Kg
020GT-006-MF-316	1/8"	0,06
020GT-008-MF-316	1/4"	0,10
020GT-010-MF-316	3/8"	0,12
020GT-015-MF-316	1/2"	0,20
020GT-020-MF-316	3/4"	0,27
020GT-025-MF-316	1"	0,31
020GT-032-MF-316	1 1/4"	0,72
020GT-040-MF-316	1 1/2"	0,80
020GT-050-MF-316	2"	1,19
020GT-065-MF-316	2 1/2"	1,81
020GT-080-MF-316	3"	2,60
020GT-100-MF-316	4"	4,55

Union flat - M/M

outside threads taper ISO 7-1R
material: AISI 316 (AISI 304) gasket PTFE

020GT-MM



ordering code ⁽²⁾	DN (Inch)	Kg
020GT-006-MM-316	1/8"	0,06
020GT-008-MM-316	1/4"	0,10
020GT-010-MM-316	3/8"	0,12
020GT-015-MM-316	1/2"	0,20
020GT-020-MM-316	3/4"	0,27
020GT-025-MM-316	1"	0,31
020GT-032-MM-316	1 1/4"	0,72
020GT-040-MM-316	1 1/2"	0,80
020GT-050-MM-316	2"	1,19
020GT-065-MM-316	2 1/2"	1,81
020GT-080-MM-316	3"	2,60
020GT-100-MM-316	4"	4,55

Union flat - BW/BW

for welding type (BW - butt weld)
material: AISI 316 (AISI 304) gasket PTFE

020GT-BW



Type 311S

ordering code ⁽²⁾	DN (Inch)	Ø BW	Kg
020GT-006-BW-316	1/8"	10,2	0,06
020GT-008-BW-316	1/4"	13,5	0,10
020GT-010-BW-316	3/8"	17,2	0,12
020GT-015-BW-316	1/2"	21,3	0,20
020GT-020-BW-316	3/4"	26,9	0,27
020GT-025-BW-316	1"	33,7	0,31
020GT-032-BW-316	1 1/4"	42,4	0,72
020GT-040-BW-316	1 1/2"	48,3	0,80
020GT-050-BW-316	2"	60,3	1,19
020GT-065-BW-316	2 1/2"	76,1	1,81
020GT-080-BW-316	3"	88,9	2,60
020GT-100-BW-316	4"	114,3	4,55

(2) end marking in code -316 use for stainless steel AISI 316 (for material AISI 304 mark -304)

* not specified dimensions and weights on demand

THREADED FITTINGS BSP (150 lbs)

Elbow union - F/F

inner threads parallel ISO 228-1G

material: AISI 316 (AISI 304) gasket PTFE

020BT-FF



Elbow union - M/F

outside thread ISO 7-1R / inner thread parallel ISO 228-1G

material: AISI 316 (AISI 304) gasket PTFE

020BT-MF



ordering code	DN (Inch)	Kg
020BT-006-FF-316	1/8"	0,10
020BT-008-FF-316	1/4"	0,10
020BT-010-FF-316	3/8"	0,12
020BT-015-FF-316	1/2"	0,26
020BT-020-FF-316	3/4"	0,35
020BT-025-FF-316	1"	0,60
020BT-032-FF-316	1 1/4"	0,68
020BT-040-FF-316	1 1/2"	0,80
020BT-050-FF-316	2"	1,50

ordering code	DN (Inch)	Kg
020BT-006-MF-316	1/8"	0,10
020BT-008-MF-316	1/4"	0,10
020BT-010-MF-316	3/8"	0,12
020BT-015-MF-316	1/2"	0,26
020BT-020-MF-316	3/4"	0,35
020BT-025-MF-316	1"	0,60
020BT-032-MF-316	1 1/4"	0,68
020BT-040-MF-316	1 1/2"	0,80
020BT-050-MF-316	2"	1,50

(2) end marking in code -316 use for stainless steel AISI 316 (for material AISI 304 mark -304)
* not specified dimensions and weights on demand

THREADED FITTINGS BSP (150 lbs)

Union conical - F/F
inner threads parallel ISO 228-1G
material: AISI 316 (AISI 304)

020GK-FF



Type 312

ordering code ⁽²⁾	DN (Inch)	Kg
020GK-006-FF-316	1/8"	0,05
020GK-008-FF-316	1/4"	0,10
020GK-010-FF-316	3/8"	0,12
020GK-015-FF-316	1/2"	0,21
020GK-020-FF-316	3/4"	0,27
020GK-025-FF-316	1"	0,32
020GK-032-FF-316	1 1/4"	0,72
020GK-040-FF-316	1 1/2"	0,80
020GK-050-FF-316	2"	1,19
020GK-065-FF-316	2 1/2"	1,88
020GK-080-FF-316	3"	2,59
020GK-100-FF-316	4"	4,54

Union conical - M/F
outside thread ISO 7-1R / inner thread parallel ISO 228-1G
material: AISI 316 (AISI 304)

020GK-MF



Type 312A

ordering code ⁽²⁾	DN (Inch)	Kg
020GK-006-MF-316	1/8"	0,06
020GK-008-MF-316	1/4"	0,11
020GK-010-MF-316	3/8"	0,13
020GK-015-MF-316	1/2"	0,23
020GK-020-MF-316	3/4"	0,31
020GK-025-MF-316	1"	0,39
020GK-032-MF-316	1 1/4"	0,85
020GK-040-MF-316	1 1/2"	0,96
020GK-050-MF-316	2"	1,47
020GK-065-MF-316	2 1/2"	2,46
020GK-080-MF-316	3"	3,45
020GK-100-MF-316	4"	5,72

Union conical - M/M
outside threads taper ISO 7-1R
material: AISI 316 (AISI 304)

020GK-MM



ordering code ⁽²⁾	DN (Inch)	Kg
020GK-006-MM-316	1/8"	0,06
020GK-008-MM-316	1/4"	0,11
020GK-010-MM-316	3/8"	0,13
020GK-015-MM-316	1/2"	0,29
020GK-020-MM-316	3/4"	0,31
020GK-025-MM-316	1"	0,39
020GK-032-MM-316	1 1/4"	0,85
020GK-040-MM-316	1 1/2"	0,96
020GK-050-MM-316	2"	1,47
020GK-065-MM-316	2 1/2"	2,46
020GK-080-MM-316	3"	3,45
020GK-100-MM-316	4"	5,72

Union conical - BW/BW
for welding type (BW - butt weld)
material: AISI 316 (AISI 304)

020GK-BW



Type 312S

ordering code ⁽²⁾	DN (Inch)	Ø BW	Kg
020GK-006-BW-316	1/8"	10,2	0,04
020GK-008-BW-316	1/4"	13,5	0,09
020GK-010-BW-316	3/8"	17,2	0,10
020GK-015-BW-316	1/2"	21,3	0,17
020GK-020-BW-316	3/4"	26,9	0,27
020GK-025-BW-316	1"	33,7	0,33
020GK-032-BW-316	1 1/4"	42,4	0,64
020GK-040-BW-316	1 1/2"	48,3	0,64
020GK-050-BW-316	2"	60,3	1,02
020GK-065-BW-316	2 1/2"	76,1	1,72
020GK-080-BW-316	3"	88,9	2,25
020GK-100-BW-316	4"	114,3	3,96

(2) end marking in code -316 use for stainless steel AISI 316 (for material AISI 304 mark -304)

* not specified dimensions and weights on demand

THREADED FITTINGS BSP (150 lbs)

Union conical - BW/F
for welding type BW / inner thread parallel ISO 228-1G
material: AISI 316 (AISI 304)

020GK-BWF



Type 312 IS

ordering code ⁽²⁾	DN (Inch)	Ø BW	Kg
020GK-006-BWF-316	1/8"	10,2	0,09
020GK-008-BWF-316	1/4"	13,5	0,09
020GK-010-BWF-316	3/8"	17,2	0,11
020GK-015-BWF-316	1/2"	21,3	0,19
020GK-020-BWF-316	3/4"	26,9	0,25
020GK-025-BWF-316	1"	33,7	0,31
020GK-032-BWF-316	1 1/4"	42,4	0,68
020GK-040-BWF-316	1 1/2"	48,3	0,72
020GK-050-BWF-316	2"	60,3	1,12
020GK-065-BWF-316	2 1/2"	76,1	2,20
020GK-080-BWF-316	3"	88,9	3,10
020GK-100-BWF-316	4"	114,3	4,50

Union conical - BW/M
for welding type BW / outside thread taper ISO 7-1R
material: AISI 316 (AISI 304)

020GK-BWM



Type 312 AS

ordering code ⁽²⁾	DN (Inch)	Ø BW	Kg
020GK-006-BWM-316	1/8"	10,2	0,09
020GK-008-BWM-316	1/4"	13,5	0,10
020GK-010-BWM-316	3/8"	17,2	0,12
020GK-015-BWM-316	1/2"	21,3	0,22
020GK-020-BWM-316	3/4"	26,9	0,29
020GK-025-BWM-316	1"	33,7	0,40
020GK-032-BWM-316	1 1/4"	42,4	0,81
020GK-040-BWM-316	1 1/2"	48,3	0,87
020GK-050-BWM-316	2"	60,3	1,37
020GK-065-BWM-316	2 1/2"	76,1	2,50
020GK-080-BWM-316	3"	88,9	3,40
020GK-100-BWM-316	4"	114,3	4,70

Elbow union conical - F/F
inner threads parallel ISO 228-1G
material: AISI 316

020BK-FF



ordering code	DN (Inch)	Kg
020BK-006-FF-316	1/8"	0,10
020BK-008-FF-316	1/4"	0,10
020BK-010-FF-316	3/8"	0,12
020BK-015-FF-316	1/2"	0,26
020BK-020-FF-316	3/4"	0,35
020BK-025-FF-316	1"	0,60
020BK-032-FF-316	1 1/4"	0,68
020BK-040-FF-316	1 1/2"	0,80
020BK-050-FF-316	2"	1,72

Elbow union conical - M/F
outside thread ISO 7-1R / inner thread parallel ISO 228-1G
material: AISI 316

020BK-MF



ordering code	DN (Inch)	Kg
020GK-006-MF-316	1/8"	0,10
020GK-008-MF-316	1/4"	0,10
020GK-010-MF-316	3/8"	0,12
020GK-015-MF-316	1/2"	0,26
020GK-020-MF-316	3/4"	0,35
020GK-025-MF-316	1"	0,60
020GK-032-MF-316	1 1/4"	0,68
020GK-040-MF-316	1 1/2"	0,68
020GK-050-MF-316	2"	1,50

(2) end marking in code -316 use for stainless steel AISI 316 (for material AISI 304 mark -304)
* not specified dimensions and weights on demand

THREADED FITTINGS BSP (150 lbs)

Union conical - H/H

(on request we can supply flat type with PTFE)

material: AISI 316

020PK-HH

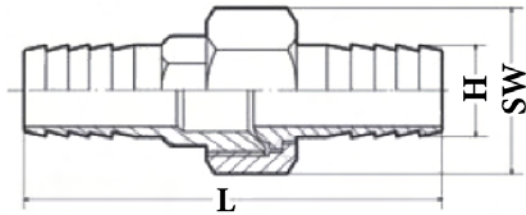

Union conical - F/H

(on request we can supply flat type with PTFE)

material: AISI 316

020PK-FH

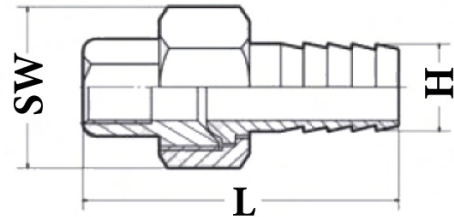

ordering code	DN (Inch)	Ø H	Kg
020PK-006-006-HH-316	1/8"	6,5	0,06
020PK-008-006-HH-316	1/4"	6,3	0,11
020PK-008-009-HH-316	1/4"	9	0,11
020PK-010-009-HH-316	3/8"	9,5	0,13
020PK-010-011-HH-316	3/8"	11	0,13
020PK-015-012-HH-316	1/2"	12,7	0,29
020PK-015-014-HH-316	1/2"	14	0,29
020PK-020-019-HH-316	3/4"	19	0,31
020PK-020-020-HH-316	3/4"	20,5	0,31
020PK-025-025-HH-316	1"	25,4	0,39
020PK-025-027-HH-316	1"	27	0,39
020PK-032-031-HH-316	1 1/4"	31,8	0,85
020PK-032-033-HH-316	1 1/4"	33	0,85
020PK-040-038-HH-316	1 1/2"	38,1	0,96
020PK-040-039-HH-316	1 1/2"	39,5	0,96
020PK-050-050-HH-316	2"	50,8	1,47
020PK-050-052-HH-316	2"	52	1,47

ordering code	DN (Inch)	Ø H	Kg
020PK-006-006-FH-316	1/8"	6,5	0,06
020PK-008-006-FH-316	1/4"	6,3	0,10
020PK-008-009-FH-316	1/4"	9	0,10
020PK-010-009-FH-316	3/8"	9,5	0,12
020PK-010-011-FH-316	3/8"	11	0,12
020PK-015-012-FH-316	1/2"	12,7	0,22
020PK-015-014-FH-316	1/2"	14	0,22
020PK-020-019-FH-316	3/4"	19	0,29
020PK-020-020-FH-316	3/4"	20,5	0,29
020PK-025-025-FH-316	1"	25,4	0,40
020PK-025-027-FH-316	1"	27	0,40
020PK-032-031-FH-316	1 1/4"	31,8	0,81
020PK-032-033-FH-316	1 1/4"	33	0,81
020PK-040-038-FH-316	1 1/2"	38,1	0,87
020PK-040-039-FH-316	1 1/2"	39,5	0,87
020PK-050-050-FH-316	2"	50,8	1,37
020PK-050-052-FH-316	2"	52	1,37

* not specified dimensions and weights on demand

THREADED FITTINGS BSP (150 lbs)

Union conical - M/H

(on request we can supply flat type with PTFE)

material: AISI 316

020PK-MH

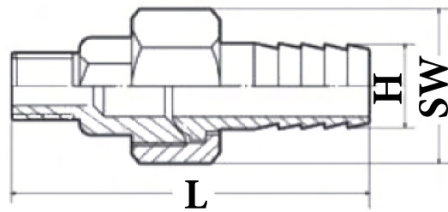

Union conical - BW/H

(on request we can supply flat type with PTFE)

material: AISI 316

020PK-BWH

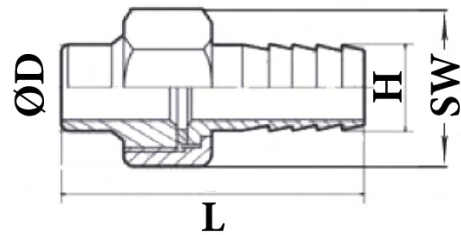

ordering code	DN (Inch)	Ø D (Hose)	Kg
020PK-006-006-MH-316	1/8"	6,5	0,06
020PK-008-006-MH-316	1/4"	6,3	0,11
020PK-008-009-MH-316	1/4"	9	0,11
020PK-010-009-MH-316	3/8"	9,5	0,13
020PK-010-011-MH-316	3/8"	11	0,13
020PK-015-012-MH-316	1/2"	12,7	0,29
020PK-015-014-MH-316	1/2"	14	0,29
020PK-020-019-MH-316	3/4"	19	0,31
020PK-020-020-MH-316	3/4"	20,5	0,31
020PK-025-025-MH-316	1"	25,4	0,39
020PK-025-027-MH-316	1"	27	0,39
020PK-032-031-MH-316	1 1/4"	31,8	0,85
020PK-032-033-MH-316	1 1/4"	33	0,85
020PK-040-038-MH-316	1 1/2"	38,1	0,96
020PK-040-039-MH-316	1 1/2"	39,5	0,96
020PK-050-050-MH-316	2"	50,8	1,47
020PK-050-052-MH-316	2"	52	1,47

ordering code	DN (Inch)	Ø D	Ø H	Kg
020PK-006-006-BWH-316	1/8"	10,2	6,5	0,06
020PK-008-006-BWH-316	1/4"	13,5	6,3	0,10
020PK-008-009-BWH-316	1/4"	13,5	9	0,10
020PK-010-009-BWH-316	3/8"	17,2	9,5	0,12
020PK-010-011-BWH-316	3/8"	17,2	11	0,12
020PK-015-012-BWH-316	1/2"	21,3	12,7	0,22
020PK-015-014-BWH-316	1/2"	21,3	14	0,22
020PK-020-019-BWH-316	3/4"	26,9	19	0,29
020PK-020-020-BWH-316	3/4"	26,9	20,5	0,29
020PK-025-025-BWH-316	1"	33,7	25,4	0,40
020PK-025-027-BWH-316	1"	33,7	27	0,40
020PK-032-031-BWH-316	1 1/4"	42,4	31,8	0,81
020PK-032-033-BWH-316	1 1/4"	42,4	33	0,81
020PK-040-038-BWH-316	1 1/2"	48,3	38,1	0,87
020PK-040-039-BWH-316	1 1/2"	48,3	39,5	0,87
020PK-050-050-BWH-316	2"	60,3	50,8	1,37
020PK-050-052-BWH-316	2"	60,3	52	1,37

* not specified dimensions and weights on demand