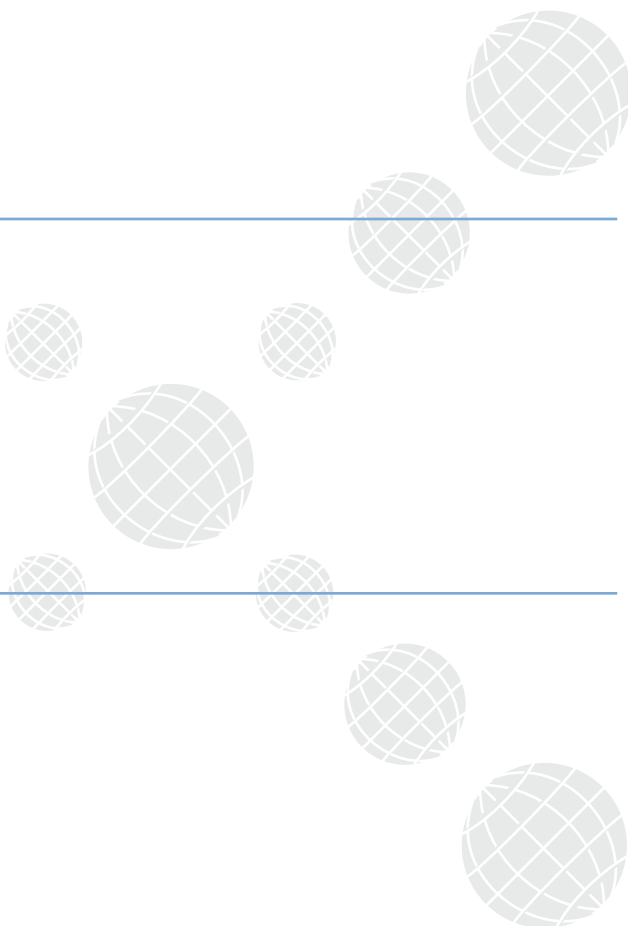

PRESS FITTINGS

Inox Press

● pipes, elbows, T-pieces ...

● adaptors, reducers, unions ...

● valves, seals ...



INOX PRESS

The advantages of the system are:

- ☞ Quick and easy installation of the system
- ☞ Simply connection

The application possibilities are endless:

- ☞ Industrial cold and warm water
- ☞ Industrial and other gases
- ☞ Compressed air installations
- ☞ Low pressure steam installations
- ☞ Air-conditioning installations
- ☞ Sanitary installations
- ☞ Suitable for visible and concealed installations
- ☞ Can be used for new construction and renovation

Material:

- ☞ The system exclusively uses fittings in AISI 316L stainless steel
- ☞ Perfectly compatible with the action of those corrosive agents present in water destined for domestic use
- ☞ Recognized throughout the world as a preferred material for use in potable water installations
- ☞ Tubes and fittings are supplied annealed at a high temperature in an inert atmosphere to enhance their characteristic resistance to corrosion and ageing

Water-tightness, Gas-tightness:

- ☞ The EPDM O-ring inserted in the fitting guarantees the water tightness of the joint
- ☞ Manufactured from 70 Shore quality EPDM
- ☞ EPDM resists ageing and attack by the common additives used in the treatment of potable water
- ☞ Special rings for gas application are available on request

Technical characteristics of the system:

- ☞ max working pressure: 16 bar
- ☞ max working temperature: 95 °C

User manual:

- 1) Cut the tubing to length
- 2) Remove all burrs to avoid possible damage to the O-ring
- 3) Check to ensure that the O-ring is present and correctly located in the fitting
- 4) Push the tube into the fitting as far as the tube stop
- 5) Mark the tube for reference before pressing
- 6) Fit the correct diameter jaws
- 7) Open the jaws of the pressing tool and insert the assembled tube and fitting to be pressed
- 8) Operate the pressing function
- 9) Check the completed joint



Tubes

Inox Press - press fittings

material: stainless steel DIN 1.4404 (AISI 316L)

I000



| Ordering code | DN | OD x wall thickness | Inner diameter | kg |
|---------------|------|---------------------|----------------|-------|
| I000-015-316L | 15 | 15 x 1 | 13 | 0,351 |
| I000-018-316L | 18 | 18 x 1 | 16 | 0,426 |
| I000-022-316L | 22 | 22 x 1,2 | 19,6 | 0,625 |
| I000-028-316L | 28 | 28 x 1,2 | 25,6 | 0,805 |
| I000-035-316L | 35 | 35 x 1,5 | 32 | 1,258 |
| I000-042-316L | 42 | 42 x 1,5 | 39 | 1,521 |
| I000-054-316L | 54 | 54 x 1,5 | 51 | 1,972 |
| I000-076-316L | 76,1 | 76,1 x 2 | 72,1 | 3,711 |
| I000-088-316L | 88,9 | 88,9 x 2 | 84,9 | 4,352 |
| I000-108-316L | 108 | 108 x 2 | 104 | 5,308 |

Sealing O-ring

Inox Press

material: EPDM (black)

FKM, NBR or request

I39E



INOX PRESS - OR seal ring

| Ordering code | DN | | | |
|---------------|------|--|--|--|
| I39E-015-EPDM | 15 | | | |
| I39E-018-EPDM | 18 | | | |
| I39E-022-EPDM | 22 | | | |
| I39E-028-EPDM | 28 | | | |
| I39E-035-EPDM | 35 | | | |
| I39E-042-EPDM | 42 | | | |
| I39E-054-EPDM | 54 | | | |
| I39E-076-EPDM | 76,1 | | | |
| I39E-088-EPDM | 88,9 | | | |
| I39E-108-EPDM | 108 | | | |

Adaptor - flange PN 16 / F (press)

Inox Press - press fittings

material: stainless steel DIN 1.4404 (AISI 316L)

I279

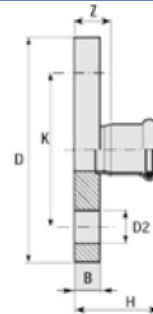

| Ordering code | DN (press) | DN (flange) | Z | H | B | D | D2 | Qty holes in flange | K |
|-------------------|------------|-------------|----|-----|----|-----|----|---------------------|-----|
| I279-015-015-316L | 15 | 15 | 18 | 38 | 11 | 95 | 14 | 4 | 65 |
| I279-018-015-316L | 18 | 15 | 19 | 39 | 11 | 95 | 14 | 4 | 65 |
| I279-022-020-316L | 22 | 20 | 20 | 41 | 12 | 105 | 14 | 4 | 75 |
| I279-028-025-316L | 28 | 25 | 23 | 46 | 14 | 115 | 14 | 4 | 85 |
| I279-035-032-316L | 35 | 32 | 24 | 50 | 15 | 140 | 18 | 4 | 100 |
| I279-042-040-316L | 42 | 40 | 25 | 55 | 16 | 150 | 18 | 4 | 110 |
| I279-054-050-316L | 54 | 50 | 28 | 63 | 18 | 165 | 18 | 4 | 125 |
| I279-076-065-316L | 76,1 | 65 | 42 | 97 | 18 | 185 | 18 | 4 | 145 |
| I279-088-080-316L | 88,9 | 80 | 45 | 105 | 20 | 200 | 18 | 8 | 160 |
| I279-108-100-316L | 108 | 100 | 48 | 123 | 20 | 220 | 18 | 8 | 180 |

Conical union - F/F

Inox Press - press fittings

material: stainless steel DIN 1.4404 (AISI 316L)

I020

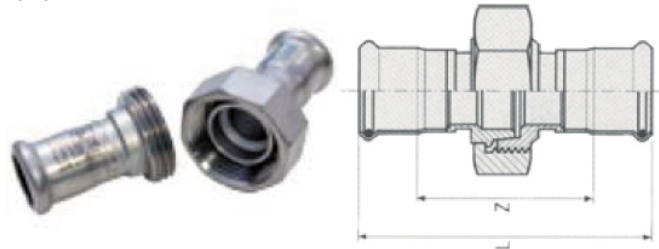

| Ordering code | DN | L | Z |
|---------------|----|-----|----|
| I020-015-316L | 15 | 96 | 56 |
| I020-018-316L | 18 | 97 | 57 |
| I020-022-316L | 22 | 99 | 57 |
| I020-028-316L | 28 | 116 | 70 |
| I020-035-316L | 35 | 123 | 71 |
| I020-042-316L | 42 | 138 | 78 |
| I020-054-316L | 54 | 154 | 84 |

Slip coupling - F/F

Inox Press - press fittings

material: stainless steel DIN 1.4404 (AISI 316L)

I022

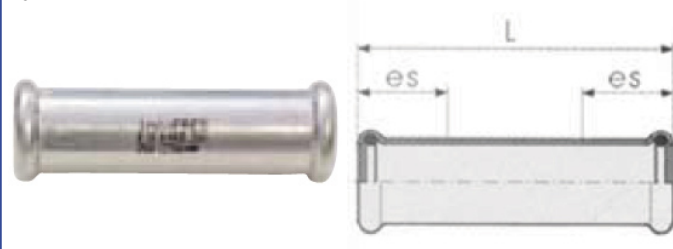

| Ordering code | DN | L | ES |
|---------------|------|-----|----|
| I022-015-316L | 15 | 80 | 25 |
| I022-018-316L | 18 | 80 | 25 |
| I022-022-316L | 22 | 84 | 25 |
| I022-028-316L | 28 | 91 | 30 |
| I022-035-316L | 35 | 102 | 30 |
| I022-042-316L | 42 | 120 | 40 |
| I022-054-316L | 54 | 140 | 40 |
| I022-076-316L | 76,1 | 230 | 60 |
| I022-088-316L | 88,9 | 260 | 70 |
| I022-108-316L | 108 | 310 | 80 |

Coupling - F/F

Inox Press - press fittings

material: stainless steel DIN 1.4404 (AISI 316L)

I023

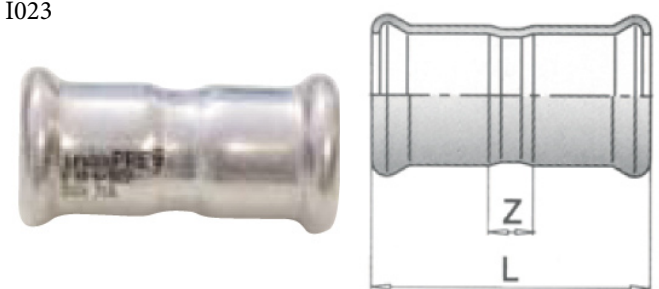

| Ordering code | DN | L | Z |
|---------------|------|-----|----|
| I023-015-316L | 15 | 49 | 9 |
| I023-018-316L | 18 | 50 | 10 |
| I023-022-316L | 22 | 53 | 11 |
| I023-028-316L | 28 | 56 | 10 |
| I023-035-316L | 35 | 63 | 10 |
| I023-042-316L | 42 | 72 | 12 |
| I023-054-316L | 54 | 83 | 13 |
| I023-076-316L | 76,1 | 142 | 32 |
| I023-088-316L | 88,9 | 166 | 46 |
| I023-108-316L | 108 | 203 | 41 |

Stop end - F

Inox Press - press fittings

material: stainless steel DIN 1.4404 (AISI 316L)

I024

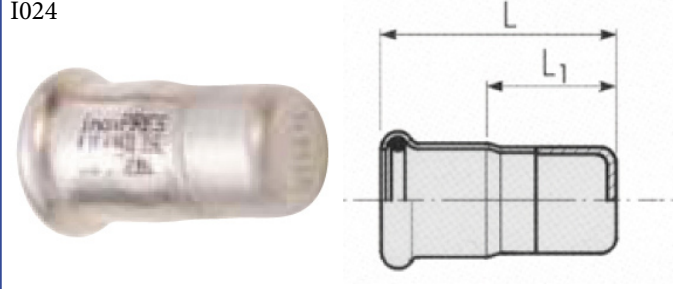

| Ordering code | DN | L | L1 |
|---------------|------|-----|----|
| I024-015-316L | 15 | 44 | 24 |
| I024-018-316L | 18 | 44 | 24 |
| I024-022-316L | 22 | 45 | 24 |
| I024-028-316L | 28 | 48 | 25 |
| I024-035-316L | 35 | 52 | 26 |
| I024-042-316L | 42 | 56 | 26 |
| I024-054-316L | 54 | 62 | 27 |
| I024-076-316L | 76,1 | 93 | 38 |
| I024-088-316L | 88,9 | 99 | 39 |
| I024-108-316L | 108 | 117 | 42 |

Valve adaptor - F (press) / Female thread (BSP)
Inox Press - press fittings
material: stainless steel DIN 1.4404 (AISI 316L)

I025



| Ordering code | DN | L | Z |
|-------------------|-------------|----|----|
| I025-015-015-316L | 15 x 1/2" | 50 | 27 |
| I025-015-020-316L | 15 x 3/4" | 56 | 30 |
| I025-018-015-316L | 18 x 1/2" | 57 | 27 |
| I025-018-020-316L | 18 x 3/4" | 50 | 30 |
| I025-022-025-316L | 22 x 1" | 52 | 36 |
| I025-028-032-316L | 28 x 1 1/4" | 57 | 46 |
| I025-035-040-316L | 35 x 1 1/2" | 63 | 52 |
| I025-042-050-316L | 42 x 2" | 68 | 64 |
| I025-054-065-316L | 54 x 2 1/2" | 77 | 81 |

Adaptor - F (press) / Female thread BSP
Inox Press - press fittings
material: stainless steel DIN 1.4404 (AISI 316L)

I027

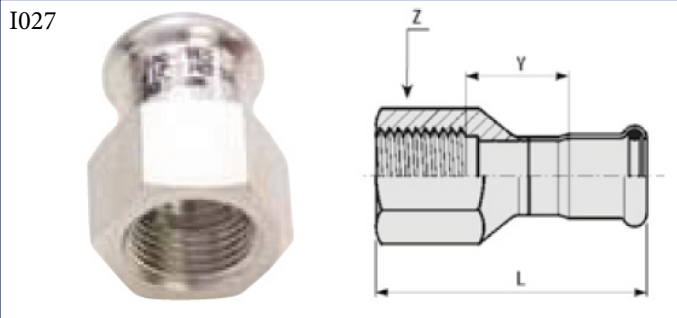

| Ordering code | DN | L | Z | Y |
|-------------------|-------------|----|----|----|
| I027-015-015-316L | 15 x 1/2" | 38 | 27 | |
| I027-018-015-316L | 18 x 1/2" | 38 | 27 | |
| I027-022-015-316L | 22 x 1/2" | 39 | 32 | |
| I027-022-020-316L | 22 x 3/4" | 40 | 32 | |
| I027-022-025-316L | 22 x 1" | 43 | 43 | |
| I027-028-020-316L | 28 x 3/4" | 42 | 38 | |
| I027-028-025-316L | 28 x 1" | 45 | 41 | |
| I027-028-032-316L | 28 x 1 1/4" | 48 | 46 | |
| I027-035-025-316L | 35 x 1" | 64 | 38 | 19 |
| I027-035-032-316L | 35 x 1 1/4" | 75 | 46 | 27 |
| I027-042-032-316L | 42 x 1 1/4" | 71 | 46 | 20 |
| I027-042-040-316L | 42 x 1 1/2" | 79 | 55 | 27 |
| I027-054-050-316L | 54 x 2" | 97 | 70 | 36 |

Adaptor - F (press) / Male thread (BSP)

Inox Press - press fittings

material: stainless steel DIN 1.4404 (AISI 316L)

I028

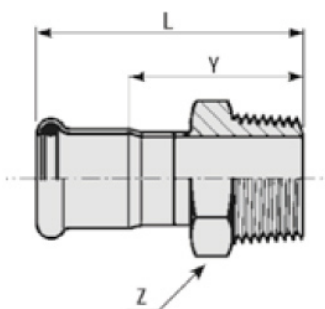

| Ordering code | DN | L | Z | Y | Ordering code | DN | L | Z | Z |
|-------------------|-------------|----|----|----|-------------------|-------------|-----|----|----|
| I028-015-010-316L | 15 x 3/8" | 38 | 24 | 18 | I028-035-032-316L | 35 x 1 1/4" | 72 | 46 | 46 |
| I028-015-015-316L | 15 x 1/2" | 41 | 24 | 21 | I028-035-025-316L | 35 x 1" | 68 | 41 | 42 |
| I028-015-020-316L | 15 x 3/4" | 43 | 30 | 23 | I028-035-032-316L | 35 x 1 1/4" | 72 | 46 | 46 |
| I028-018-015-316L | 18 x 1/2" | 41 | 27 | 21 | I028-035-040-316L | 35 x 1 1/2" | 75 | 55 | 49 |
| I028-018-020-316L | 18 x 3/4" | 44 | 30 | 24 | I028-042-032-316L | 42 x 1 1/4" | 77 | 50 | 47 |
| I028-022-015-316L | 22 x 1/2" | 42 | 32 | 21 | I028-042-040-316L | 42 x 1 1/2" | 77 | 55 | 47 |
| I028-022-020-316L | 22 x 3/4" | 44 | 32 | 23 | I028-054-040-316L | 54 x 1 1/2" | 85 | 65 | 50 |
| I028-022-025-316L | 22 x 1" | 46 | 36 | 25 | I028-054-050-316L | 54 x 2" | 89 | 65 | 54 |
| I028-028-020-316L | 28 x 3/4" | 47 | 38 | 24 | I028-076-065-316L | 76,1x2 1/2" | 124 | 80 | 69 |
| I028-028-025-316L | 28 x 1" | 48 | 38 | 25 | I028-088-080-316L | 88,9 x 3" | 138 | 95 | 78 |
| I028-028-032-316L | 28 x 1 1/4" | 53 | 46 | 30 | I028-108-100-316L | 108 x 4" | | | |
| I028-035-025-316L | 35 x 1" | 68 | 41 | 42 | | | | | |

Reducer - M (press) / F (press)

Inox Press - press fittings

material: stainless steel DIN 1.4404 (AISI 316L)

I029

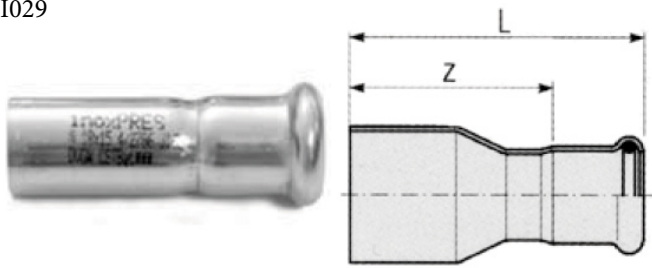

| Ordering code | DN | L | Z |
|-------------------|----------|-----|-----|
| I029-018-015-316L | 18 x 15 | 57 | 37 |
| I029-022-015-316L | 22 x 15 | 64 | 44 |
| I029-022-018-316L | 22 x 18 | 60 | 40 |
| I029-028-015-316L | 28 x 15 | 77 | 57 |
| I029-028-018-316L | 28 x 18 | 75 | 55 |
| I029-028-022-316L | 28 x 22 | 65 | 44 |
| I029-035-015-316L | 35 x 15 | 84 | 64 |
| I029-035-018-316L | 35 x 18 | 81 | 61 |
| I029-035-022-316L | 35 x 22 | 80 | 59 |
| I029-035-028-316L | 35 x 28 | 71 | 48 |
| I029-042-015-316L | 42 x 15 | 87 | 67 |
| I029-042-018-316L | 42 x 18 | 87 | 67 |
| I029-042-022-316L | 42 x 22 | 97 | 76 |
| I029-042-028-316L | 42 x 28 | 93 | 70 |
| I029-042-035-316L | 42 x 35 | 81 | 55 |
| I029-054-015-316L | 54 x 15 | 98 | 78 |
| I029-054-018-316L | 54 x 18 | 98 | 78 |
| I029-054-022-316L | 54 x 22 | 99 | 78 |
| I029-054-028-316L | 54 x 28 | 109 | 86 |
| I029-054-035-316L | 54 x 35 | 108 | 82 |
| I029-054-042-316L | 54 x 42 | 98 | 68 |
| I029-076-054-316L | 76 x 54 | 147 | 112 |
| I029-088-054-316L | 88 x 54 | 160 | 125 |
| I029-088-076-316L | 88 x 76 | 184 | 129 |
| I029-108-054-316L | 108 x 54 | 178 | 143 |
| I029-108-076-316L | 108 x 76 | 203 | 148 |
| I029-108-088-316L | 108 x 88 | 207 | 147 |

Pipe bridge- M (press) / M (press)

Inox Press - press fittings

material: stainless steel DIN 1.4404 (AISI 316L)

I030

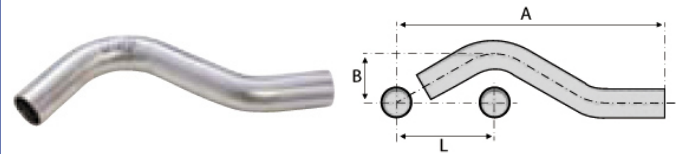

| Ordering code | DN | L | A | B |
|---------------|----|----|-----|----|
| I030-015-316L | 15 | 57 | 158 | 42 |
| I030-018-316L | 18 | 60 | 166 | 44 |
| I030-022-316L | 22 | 76 | 189 | 48 |
| I030-028-316L | 28 | 74 | 201 | 54 |

T-piece - F/F/F

Inox Press - press fittings

material: stainless steel DIN 1.4404 (AISI 316L)

I032

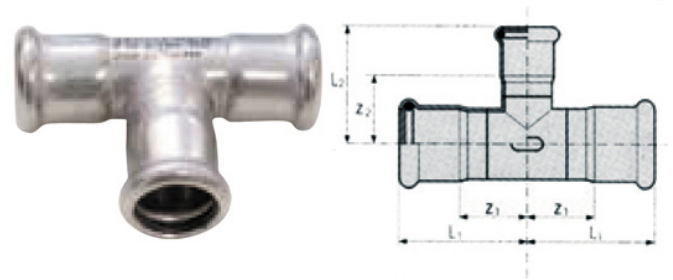

| Ordering code | DN | L1 | L2 | Z1 | Z2 |
|---------------|------|-----|-----|----|----|
| I032-015-316L | 15 | 34 | 39 | 14 | 19 |
| I032-018-316L | 18 | 37 | 41 | 16 | 21 |
| I032-022-316L | 22 | 39 | 45 | 18 | 24 |
| I032-028-316L | 28 | 44 | 50 | 21 | 27 |
| I032-035-316L | 35 | 51 | 57 | 25 | 31 |
| I032-042-316L | 42 | 59 | 65 | 28 | 35 |
| I032-054-316L | 54 | 70 | 77 | 34 | 42 |
| I032-076-316L | 76,1 | 108 | 118 | 52 | 63 |
| I032-088-316L | 88,9 | 132 | 131 | 72 | 71 |
| I032-108-316L | 108 | 155 | 159 | 74 | 84 |

T-piece with Female BSP outlet - F(press) / F(BSP) / F(press)
Inox Press - press fittings
material: stainless steel DIN 1.4404 (AISI 316L)

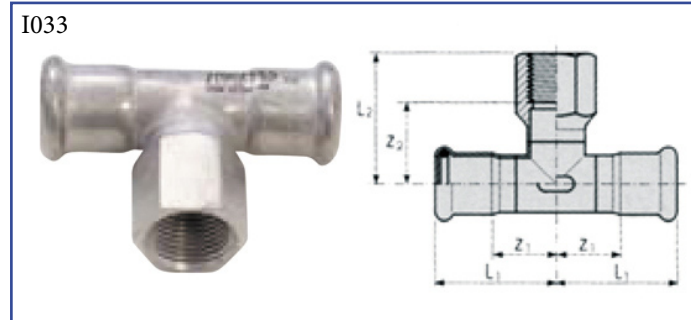

T-piece reducing - F/F/F
Inox Press - press fittings
material: stainless steel DIN 1.4404 (AISI 316L)



| Ordering code | DN | L1 | L2 | Z1 | Z2 |
|-------------------|--------------------|-----|-----|----|----|
| I033-015-015-316L | 15 x 1/2" x 15 | 34 | 40 | 13 | 25 |
| I033-018-015-316L | 18 x 1/2" x 18 | 37 | 42 | 16 | 27 |
| I033-018-020-316L | 18 x 3/4" x 18 | 37 | 45 | 16 | 28 |
| I033-022-015-316L | 22 x 1/2" x 22 | 39 | 44 | 18 | 29 |
| I033-022-020-316L | 22 x 3/4" x 22 | 39 | 47 | 18 | 31 |
| I033-028-015-316L | 28 x 1/2" x 28 | 44 | 47 | 21 | 32 |
| I033-028-020-316L | 28 x 3/4" x 28 | 44 | 50 | 21 | 33 |
| I033-028-025-316L | 28 x 1" x 28 | 44 | 53 | 21 | 34 |
| I033-035-015-316L | 35 x 1/2" x 35 | 51 | 51 | 25 | 36 |
| I033-035-020-316L | 35 x 3/4" x 35 | 51 | 54 | 25 | 37 |
| I033-035-025-316L | 35 x 1" x 35 | 51 | 47 | 22 | 28 |
| I033-042-015-316L | 42 x 1/2" x 42 | 59 | 54 | 28 | 39 |
| I033-042-020-316L | 42 x 3/4" x 42 | 59 | 57 | 28 | 41 |
| I033-054-015-316L | 54 x 1/2" x 54 | 70 | 61 | 34 | 46 |
| I033-054-020-316L | 54 x 3/4" x 54 | 70 | 64 | 34 | 48 |
| I033-054-050-316L | 54 x 2" x 54 | 70 | 81 | 34 | 55 |
| I033-076-020-316L | 76,1 x 3/4" x 76,1 | 108 | 77 | 52 | 60 |
| I033-076-050-316L | 76,1 x 2" x 76,1 | 108 | 93 | 52 | 67 |
| I033-088-020-316L | 88,9 x 3/4" x 88,9 | 132 | 84 | 72 | 67 |
| I033-088-050-316L | 88,9 x 2" x 88,9 | 132 | 100 | 72 | 74 |
| I033-108-020-316L | 108 x 3/4" x 108 | 155 | 94 | 74 | 77 |
| I033-108-050-316L | 108 x 2" x 108 | 155 | 110 | 74 | 84 |

| Ordering code | DN | L1 | L2 | Z1 | Z2 |
|-------------------|--------------------|-----|-----|----|----|
| I034-018-015-316L | 18 x 15 x 18 | 37 | 41 | 16 | 21 |
| I034-022-015-316L | 22 x 15 x 22 | 39 | 43 | 18 | 23 |
| I034-022-018-316L | 22 x 18 x 22 | 39 | 44 | 18 | 23 |
| I034-028-015-316L | 28 x 15 x 28 | 44 | 46 | 21 | 26 |
| I034-028-018-316L | 28 x 18 x 28 | 44 | 46 | 21 | 26 |
| I034-028-022-316L | 28 x 22 x 28 | 44 | 47 | 21 | 26 |
| I034-035-015-316L | 35 x 15 x 35 | 51 | 49 | 25 | 29 |
| I034-035-018-316L | 35 x 18 x 35 | 51 | 50 | 25 | 30 |
| I034-035-022-316L | 35 x 22 x 35 | 51 | 51 | 25 | 30 |
| I034-035-028-316L | 35 x 28 x 35 | 51 | 54 | 25 | 31 |
| I034-042-022-316L | 42 x 22 x 42 | 59 | 54 | 28 | 33 |
| I034-042-028-316L | 42 x 28 x 42 | 59 | 57 | 28 | 34 |
| I034-042-035-316L | 42 x 35 x 42 | 59 | 61 | 28 | 35 |
| I034-054-022-316L | 54 x 22 x 54 | 70 | 62 | 34 | 41 |
| I034-054-028-316L | 54 x 28 x 54 | 70 | 65 | 34 | 42 |
| I034-054-035-316L | 54 x 35 x 54 | 70 | 68 | 34 | 42 |
| I034-054-042-316L | 54 x 42 x 54 | 70 | 72 | 34 | 42 |
| I034-076-022-316L | 76,1 x 22 x 76,1 | 108 | 74 | 52 | 53 |
| I034-076-028-316L | 76,1 x 28 x 76,1 | 108 | 77 | 52 | 54 |
| I034-076-035-316L | 76,1 x 35 x 76,1 | 108 | 80 | 52 | 54 |
| I034-076-042-316L | 76,1 x 42 x 76,1 | 108 | 84 | 52 | 54 |
| I034-076-054-316L | 76,1 x 54 x 76,1 | 108 | 90 | 52 | 55 |
| I034-088-022-316L | 88,9 x 22 x 88,9 | 132 | 81 | 72 | 60 |
| I034-088-028-316L | 88,9 x 28 x 88,9 | 132 | 84 | 72 | 61 |
| I034-088-035-316L | 88,9 x 35 x 88,9 | 132 | 88 | 72 | 62 |
| I034-088-042-316L | 88,9 x 42 x 88,9 | 132 | 91 | 72 | 61 |
| I034-088-054-316L | 88,9 x 54 x 88,9 | 132 | 97 | 72 | 62 |
| I034-088-076-316L | 88,9 x 76,1 x 88,9 | 132 | 125 | 72 | 70 |
| I034-108-022-316L | 108 x 22 x 108 | 155 | 91 | 74 | 70 |
| I034-108-028-316L | 108 x 28 x 108 | 155 | 94 | 74 | 71 |
| I034-108-035-316L | 108 x 35 x 108 | 155 | 97 | 74 | 71 |
| I034-108-042-316L | 108 x 42 x 108 | 155 | 101 | 74 | 71 |
| I034-108-054-316L | 108 x 54 x 108 | 155 | 107 | 74 | 72 |
| I034-108-076-316L | 108 x 76,1 x 108 | 155 | 135 | 74 | 80 |
| I034-108-088-316L | 108 x 88,9 x 108 | 155 | 141 | 74 | 81 |

Elbow 45° F/ F

Inox Press - press fittings

material: stainless steel DIN 1.4404 (AISI 316L)

I045

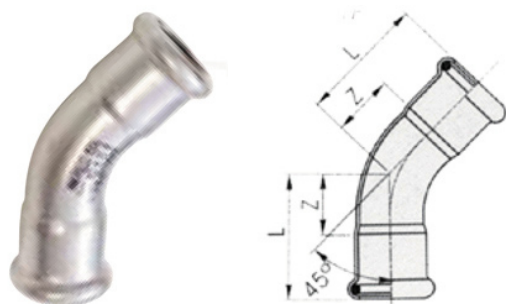

Elbow 45° M/F

Inox Press - press fittings

material: stainless steel DIN 1.4404 (AISI 316L)

I046

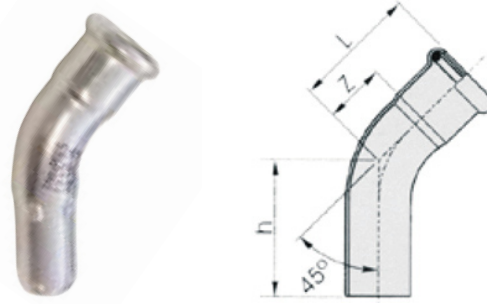

| Ordering code | D | L | Z |
|---------------|------|-----|----|
| I045-015-316L | 15 | 36 | 16 |
| I045-018-316L | 18 | 37 | 17 |
| I045-022-316L | 22 | 41 | 20 |
| I045-028-316L | 28 | 47 | 24 |
| I045-035-316L | 35 | 54 | 28 |
| I045-042-316L | 42 | 75 | 45 |
| I045-054-316L | 54 | 91 | 56 |
| I045-076-316L | 76,1 | 133 | 78 |
| I045-088-316L | 88,9 | 144 | 84 |
| I045-108-316L | 108 | 169 | 94 |

| Ordering code | D | L | H | Z |
|---------------|------|-----|-----|----|
| I046-015-316L | 15 | 36 | 49 | 16 |
| I046-018-316L | 18 | 37 | 43 | 17 |
| I046-022-316L | 22 | 41 | 48 | 20 |
| I046-028-316L | 28 | 48 | 55 | 24 |
| I046-035-316L | 35 | 55 | 68 | 29 |
| I046-042-316L | 42 | 75 | 96 | 45 |
| I046-054-316L | 54 | 91 | 107 | 56 |
| I046-076-316L | 76,1 | 133 | 143 | 78 |
| I046-088-316L | 88,9 | 144 | 160 | 84 |
| I046-108-316L | 108 | 169 | 186 | 94 |

Elbow 90° F/ F

Inox Press - press fittings

material: stainless steel DIN 1.4404 (AISI 316L)

I090

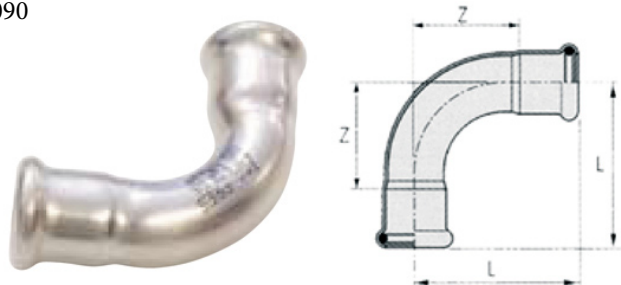

Elbow 90° M/F

Inox Press - press fittings

material: stainless steel DIN 1.4404 (AISI 316L)

I091

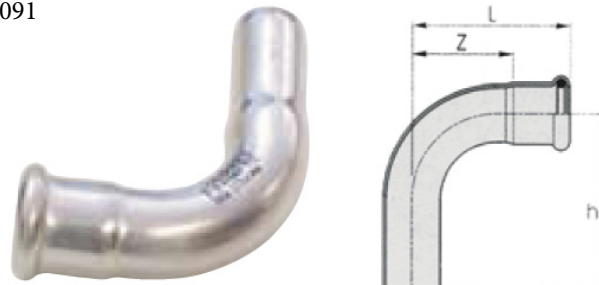

| Ordering code | D | L | Z |
|---------------|------|-----|-----|
| I090-015-316L | 15 | 50 | 30 |
| I090-018-316L | 18 | 54 | 34 |
| I090-022-316L | 22 | 60 | 39 |
| I090-028-316L | 28 | 73 | 50 |
| I090-035-316L | 35 | 86 | 60 |
| I090-042-316L | 42 | 112 | 82 |
| I090-054-316L | 54 | 138 | 103 |
| I090-076-316L | 76,1 | 160 | 105 |
| I090-088-316L | 88,9 | 182 | 122 |
| I090-108-316L | 108 | 220 | 145 |

| Ordering code | D | L | H | Z |
|---------------|------|-----|-----|-----|
| I091-015-316L | 15 | 50 | 63 | 30 |
| I091-018-316L | 18 | 54 | 63 | 34 |
| I091-022-316L | 22 | 60 | 71 | 39 |
| I091-028-316L | 28 | 73 | 81 | 50 |
| I091-035-316L | 35 | 86 | 100 | 60 |
| I091-042-316L | 42 | 112 | 133 | 82 |
| I091-054-316L | 54 | 138 | 152 | 103 |
| I091-076-316L | 76,1 | 160 | 180 | 105 |
| I091-088-316L | 88,9 | 182 | 197 | 122 |
| I091-108-316L | 108 | 220 | 236 | 145 |

Adaptor - elbow 90° - F (press) / Female thread (BSP)
 Inox Press - press fittings
 material: stainless steel DIN 1.4404 (AISI 316L)

Adaptor - elbow 90° F (press) / Male thread BSP
 Inox Press - press fittings
 material: stainless steel DIN 1.4404 (AISI 316L)

I092

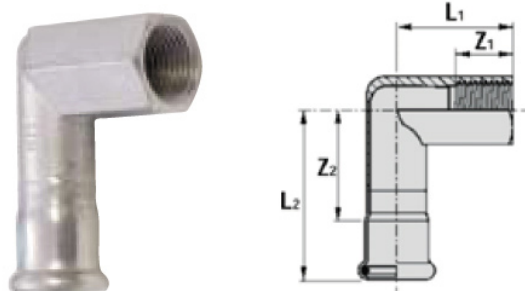

I093

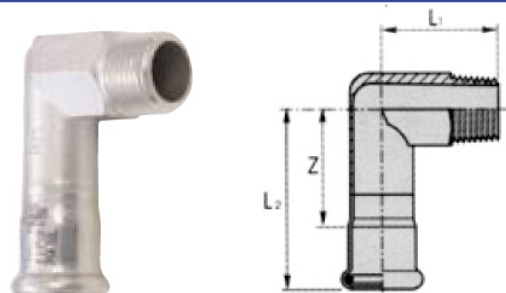

| Ordering code | DN | L1 | L2 | Z1 | Z2 |
|-------------------|-------------|----|----|----|----|
| I092-015-015-316L | 15 x 1/2" | 28 | 57 | 15 | 37 |
| I092-015-020-316L | 15 x 3/4" | 34 | 38 | 15 | 18 |
| I092-018-015-316L | 18 x 1/2" | 39 | 58 | 15 | 38 |
| I092-022-020-316L | 22 x 3/4" | 46 | 61 | 19 | 40 |
| I092-028-015-316L | 28 x 1/2" | 44 | 62 | 15 | 39 |
| I092-028-025-316L | 28 x 1" | 54 | 68 | 19 | 45 |
| I092-035-032-316L | 35 x 1 1/4" | 63 | 75 | 21 | 49 |

| Ordering code | DN | L1 | L2 | Z |
|-------------------|-------------|----|----|----|
| I093-015-015-316L | 15 x 1/2" | 37 | 57 | 37 |
| I093-018-015-316L | 18 x 1/2" | 37 | 57 | 38 |
| I093-022-020-316L | 22 x 3/4" | 39 | 61 | 40 |
| I093-028-025-316L | 28 x 1" | 44 | 68 | 45 |
| I093-035-032-316L | 35 x 1 1/4" | 49 | 75 | 49 |
| I093-042-040-316L | 42 x 1 1/2" | 54 | 84 | 54 |
| I093-054-050-316L | 54 x 2" | 60 | 95 | 60 |

Elbow 90° - F (press) / Female thread (BSP) with wall plate
 Inox Press - press fittings
 material: stainless steel DIN 1.4404 (AISI 316L)

I094

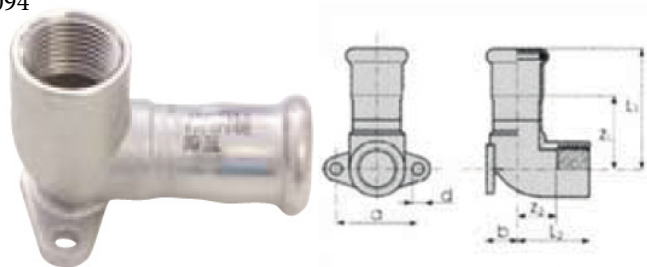

| Ordering code | DN | L1 | L2 | Z1 | Z2 | A | B | D |
|-------------------|-----------|----|----|----|----|----|----|---|
| I092-015-015-316L | 15 x 1/2" | 50 | 30 | 30 | 17 | 34 | 13 | 5 |
| I092-015-020-316L | 18 x 1/2" | 51 | 30 | 31 | 17 | 34 | 13 | 5 |
| I092-035-032-316L | 22 x 3/4" | 55 | 34 | 34 | 19 | 40 | 17 | 6 |