

ASEPTIC PROGRAM



Steril Verschraubung DIN 11864-1-A

Aseptic screwed pipe complete union
DIN 11864-1-A

Dimensions:

DIN 11866-A (DIN 11850)
DIN 11866-B (EN ISO 1127)
DIN 11866-C (ASME BPE)

Marking:

dimension, material, heat number

Tolerance:

DIN 11864 / ISO 2768-1 / DIN 405-2

Material:

AISI 316L at medium contact surface
AISI 304 nut (not at medium contact surface)
EPDM seal (standard), other materials on demand

Certificate (on demand):

EN 10204 3.1
EN 10204 3.1 AD-W2 (for selected items)

Standard surface („MB“):

inside: Ra ≤ 0,8 μm
outside: Ra ≤ 1,6 μm

Inner surface variants:

electrochemical polished
Ra ≤ 0,6 μm (STERI-line®)
Ra ≤ 0,5 μm (STERI-line®)
Ra ≤ 0,4 μm (HQ-line®)
Ra ≤ 0,25 μm (HQ-line®)

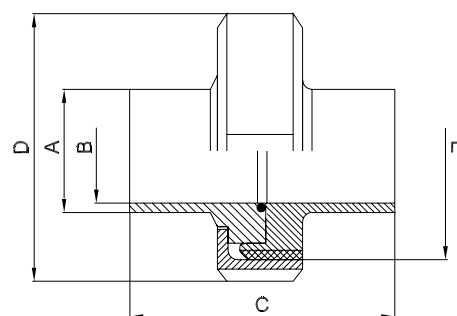

DIN	pipe	A	B	C	D	E (Rd)
DN 10*	12,0 x 1,0	12,0	10,0	76,0	38,0	28 x 1/8"
DN 10	13,0 x 1,5	13,0	10,0	76,0	38,0	28 x 1/8"
DN 15	19,0 x 1,5	19,0	16,0	76,0	44,0	34 x 1/8"
DN 20	23,0 x 1,5	23,0	20,0	76,0	54,0	44 x 1/6"
DN 25	29,0 x 1,5	29,0	26,0	77,0	63,0	52 x 1/6"
DN 32	35,0 x 1,5	35,0	32,0	88,0	70,0	58 x 1/6"
DN 40	41,0 x 1,5	41,0	38,0	88,0	78,0	65 x 1/6"
DN 50	53,0 x 1,5	53,0	50,0	89,0	92,0	78 x 1/6"
DN 65	70,0 x 2,0	70,0	66,0	113,0	112,0	95 x 1/6"
DN 80	85,0 x 2,0	85,0	81,0	117,0	127,0	110 x 1/4"
DN 100	104,0 x 2,0	104,0	100,0	120,0	148,0	130 x 1/4"

ISO	pipe	A	B	C	D	E (Rd)
DN 8	13,5 x 1,6	13,5	10,3	76,0	38,0	28 x 1/8"
DN 10	17,2 x 1,6	17,2	14,0	76,0	44,0	34 x 1/8"
DN 15	21,3 x 1,6	21,3	18,1	78,0	54,0	44 x 1/6"
DN 20	26,9 x 1,6	26,9	23,7	78,0	63,0	52 x 1/6"
DN 25	33,7 x 2,0	33,7	29,7	88,0	70,0	58 x 1/6"
DN 32	42,4 x 2,0	42,4	38,4	88,0	78,0	65 x 1/6"
DN 40	48,3 x 2,0	48,3	44,3	90,0	92,0	78 x 1/6"
DN 50	60,3 x 2,0	60,3	56,3	114,0	112,0	95 x 1/6"
DN 65	76,1 x 2,0	76,1	72,1	117,0	127,0	110 x 1/4"
DN 80	88,9 x 2,3	88,9	84,3	122,0	148,0	130 x 1/4"
DN 100	114,3 x 2,3	114,3	109,7	130,0	178,0	160 x 1/4"

ASME BPE	pipe	A	B	C	D	E (Rd)
DN 1/2"	12,7 x 1,65	12,7	9,4	76,0	38,0	28 x 1/8"
DN 3/4"	19,05 x 1,65	19,05	15,75	76,0	44,0	34 x 1/8"
DN 1"	25,4 x 1,65	25,4	22,1	77,0	63,0	52 x 1/6"
DN 1 1/2"	38,1 x 1,65	38,1	34,8	88,0	78,0	65 x 1/6"
DN 2"	50,8 x 1,65	50,8	47,5	89,0	92,0	78 x 1/6"
DN 2 1/2"	63,5 x 1,65	63,5	60,2	115,0	112,0	95 x 1/6"
DN 3"	76,2 x 1,65	76,2	72,9	117,0	127,0	110 x 1/4"
DN 4"	101,6 x 2,11	101,6	97,38	119,0	148,0	130 x 1/4"

jiné pipey na přání

*) non-standard

ASEPTIC PROGRAM



Hygiene Verschraubung DIN 11853-1

Hygienic screwed pipe connection complete
DIN 11853-1

Dimensions:

DIN 11866-A (DIN 11850)
DIN 11866-B (EN ISO 1127)
DIN 11866-C (ASME BPE)

Marking:

dimension, material, heat number

Tolerance:

DIN 11853 / ISO 2768-1 / DIN 405-2

Material:

AISI 316L at medium contact surface
AISI 304 nut (not at medium contact surface)
EPDM seal (standard), other materials on demand

Certificate (on demand):

EN 10204 3.1
EN 10204 3.1 AD-W2 (for selected items)

Standard surface („MB“):

inside: $Ra \leq 0,8 \mu\text{m}$
outside: $Ra \leq 1,6 \mu\text{m}$

Inner surface variants:

electrochemical polished
 $Ra \leq 0,6 \mu\text{m}$ (STERI-line®)
 $Ra \leq 0,5 \mu\text{m}$ (STERI-line®)
 $Ra \leq 0,4 \mu\text{m}$ (HQ-line®)
 $Ra \leq 0,25 \mu\text{m}$ (HQ-line®)

DIN	pipe	A	B	C	D	E (Rd)
DN 10	13,0 x 1,5	13,0	10,0	32,0	38,0	28 x 1/8"
DN 15	19,0 x 1,5	19,0	16,0	32,0	44,0	34 x 1/8"
DN 20	23,0 x 1,5	23,0	20,0	34,0	54,0	44 x 1/6"
DN 25	29,0 x 1,5	29,0	26,0	42,0	63,0	52 x 1/6"
DN 32	35,0 x 1,5	35,0	32,0	48,0	70,0	58 x 1/6"
DN 40	41,0 x 1,5	41,0	38,0	50,0	78,0	65 x 1/6"
DN 50	53,0 x 1,5	53,0	50,0	54,0	92,0	78 x 1/6"
DN 65	70,0 x 2,0	70,0	66,0	62,0	112,0	95 x 1/6"
DN 80	85,0 x 2,0	85,0	81,0	72,0	127,0	110 x 1/4"
DN 100	104,0 x 2,0	104,0	100,0	86,0	148,0	130 x 1/4"

ISO	pipe	A	B	C	D	E (Rd)
DN 8	13,5 x 1,6	13,5	10,3	32,0	38,0	28 x 1/8"
DN 10	17,2 x 1,6	17,2	14,0	32,0	44,0	34 x 1/8"
DN 15	21,3 x 1,6	21,3	18,1	34,0	54,0	44 x 1/6"
DN 20	26,9 x 1,6	26,9	23,7	42,0	63,0	52 x 1/6"
DN 25	33,7 x 2,0	33,7	29,7	48,0	70,0	58 x 1/6"
DN 32	42,4 x 2,0	42,4	38,4	50,0	78,0	65 x 1/6"
DN 40	48,3 x 2,0	48,3	44,3	54,0	92,0	78 x 1/6"
DN 50	60,3 x 2,0	60,3	56,3	62,0	112,0	95 x 1/6"
DN 65	76,1 x 2,0	76,1	72,1	72,0	127,0	110 x 1/4"
DN 80	88,9 x 2,3	88,9	84,3	86,0	148,0	130 x 1/4"
DN 100	114,3 x 2,3	114,3	109,7	86,0	178,0	160 x 1/4"

*) non-standard

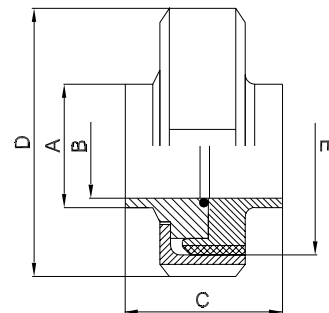

ASME BPE	pipe	A	B	C	D	E (Rd)
DN 1/2"	12,7 x 1,65	12,7	9,4	32,0	38,0	28 x 1/8"
DN 3/4"	19,05 x 1,65	19,05	15,75	32,0	44,0	34 x 1/8"
DN 1"	25,4 x 1,65	25,4	22,1	42,0	63,0	52 x 1/6"
DN 1 1/2"	38,1 x 1,65	38,1	34,8	50,0	78,0	65 x 1/6"
DN 2"	50,8 x 1,65	50,8	47,5	54,0	92,0	78 x 1/6"
DN 2 1/2"	63,5 x 1,65	63,5	60,2	62,0	112,0	95 x 1/6"
DN 3"	76,2 x 1,65	76,2	72,9	72,0	127,0	110 x 1/4"
DN 4"	101,6 x 2,11	101,6	97,38	86,0	148,0	130 x 1/4"

ASEPTIC PROGRAM

Aseptic male part DIN 11864-1-A

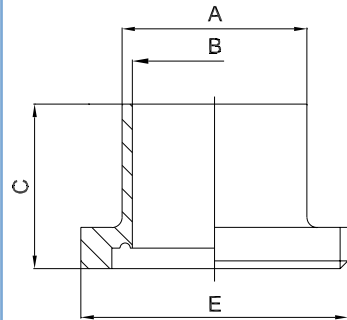

Steril Gewindestutzen

Aseptic liner DIN 11864-1-A

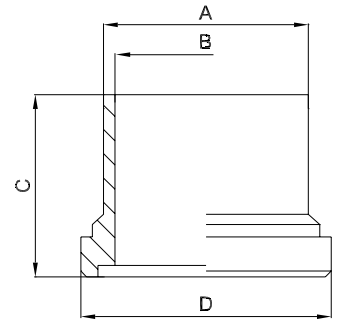

Steril Bundstutzen

DIN	pipe	A	B	C	E (Rd)
DN 10*	12,0 x 1,0	12,0	10,0	41,0	28 x 1/8"
DN 10	13,0 x 1,5	13,0	10,0	41,0	28 x 1/8"
DN 15	19,0 x 1,5	19,0	16,0	41,0	34 x 1/8"
DN 20	23,0 x 1,5	23,0	20,0	43,0	44 x 1/6"
DN 25	29,0 x 1,5	29,0	26,0	43,0	52 x 1/6"
DN 32	35,0 x 1,5	35,0	32,0	48,0	58 x 1/6"
DN 40	41,0 x 1,5	41,0	38,0	48,0	65 x 1/6"
DN 50	53,0 x 1,5	53,0	50,0	48,0	78 x 1/6"
DN 65	70,0 x 2,0	70,0	66,0	60,0	95 x 1/6"
DN 80	85,0 x 2,0	85,0	81,0	64,0	110 x 1/4"
DN 100	104,0 x 2,0	104,0	100,0	64,0	130 x 1/4"

DIN	pipe	A	B	C	D
DN 10*	12,0 x 1,0	12,0	10,0	39,0	21,9
DN 10	13,0 x 1,5	13,0	10,0	39,0	21,9
DN 15	19,0 x 1,5	19,0	16,0	39,0	27,9
DN 20	23,0 x 1,5	23,0	20,0	38,0	35,9
DN 25	29,0 x 1,5	29,0	26,0	40,0	42,9
DN 32	35,0 x 1,5	35,0	32,0	47,0	48,9
DN 40	41,0 x 1,5	41,0	38,0	47,0	54,9
DN 50	53,0 x 1,5	53,0	50,0	48,0	66,9
DN 65	70,0 x 2,0	70,0	66,0	61,0	84,9
DN 80	85,0 x 2,0	85,0	81,0	61,0	98,9
DN 100	104,0 x 2,0	104,0	100,0	66,0	118,9

ISO	pipe	A	B	C	E (Rd)
DN 8	13,5 x 1,6	13,5	10,3	41,0	28 x 1/8"
DN 10	17,2 x 1,6	17,2	14,0	41,0	34 x 1/8"
DN 15	21,3 x 1,6	21,3	18,1	43,0	44 x 1/6"
DN 20	26,9 x 1,6	26,9	23,7	43,0	52 x 1/6"
DN 25	33,7 x 2,0	33,7	29,7	48,0	58 x 1/6"
DN 32	42,4 x 2,0	42,4	38,4	48,0	65 x 1/6"
DN 40	48,3 x 2,0	48,3	44,3	49,0	78 x 1/6"
DN 50	60,3 x 2,0	60,3	56,3	60,0	95 x 1/6"
DN 65	76,1 x 2,0	76,1	72,1	64,0	110 x 1/4"
DN 80	88,9 x 2,3	88,9	84,3	64,0	130 x 1/4"
DN 100	114,3 x 2,3	114,3	109,7	68,0	160 x 1/4"

ISO	pipe	A	B	C	D
DN 8	13,5 x 1,6	13,5	10,3	39,0	21,9
DN 10	17,2 x 1,6	17,2	14,0	39,0	27,9
DN 15	21,3 x 1,6	21,3	18,1	40,0	35,9
DN 20	26,9 x 1,6	26,9	23,7	41,0	42,9
DN 25	33,7 x 2,0	33,7	29,7	47,0	48,9
DN 32	42,4 x 2,0	42,4	38,4	47,0	54,9
DN 40	48,3 x 2,0	48,3	44,3	48,0	66,9
DN 50	60,3 x 2,0	60,3	56,3	62,0	84,9
DN 65	76,1 x 2,0	76,1	72,1	61,0	98,9
DN 80	88,9 x 2,3	88,9	84,3	68,0	118,9
DN 100	114,3 x 2,3	114,3	109,7	72,0	147,9

ASME BPE	pipe	A	B	C	E (Rd)
DN 1/2"	12,7 x 1,65	12,7	9,4	41,0	28 x 1/8"
DN 3/4"	19,05 x 1,65	19,05	15,75	41,0	34 x 1/8"
DN 1"	25,4 x 1,65	25,4	22,1	43,0	52 x 1/6"
DN 1 1/2"	38,1 x 1,65	38,1	34,8	48,5	65 x 1/6"
DN 2"	50,8 x 1,65	50,8	47,5	48,5	78 x 1/6"
DN 2 1/2"	63,5 x 1,65	63,5	60,2	60,0	95 x 1/6"
DN 3"	76,2 x 1,65	76,2	72,9	64,0	110 x 1/4"
DN 4"	101,6 x 2,11	101,6	97,38	64,0	130 x 1/4"

ASME BPE	pipe	A	B	C	D
DN 1/2"	12,7 x 1,65	12,7	9,4	39,0	21,9
DN 3/4"	19,05 x 1,65	19,05	15,75	39,0	27,9
DN 1"	25,4 x 1,65	25,4	22,1	40,0	42,9
DN 1 1/2"	38,1 x 1,65	38,1	34,8	46,5	54,9
DN 2"	50,8 x 1,65	50,8	47,5	47,5	66,9
DN 2 1/2"	63,5 x 1,65	63,5	60,2	63,0	84,9
DN 3"	76,2 x 1,65	76,2	72,9	61,0	98,9
DN 4"	101,6 x 2,11	101,6	97,38	65,0	118,9

*) non-standard

ASEPTIC PROGRAM

Hygienic male part DIN 11853-1

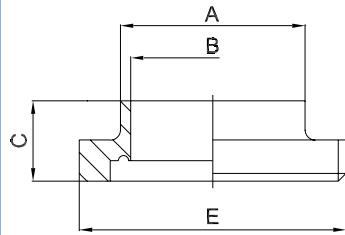

Hygiene Gewindestutzen

Hygienic liner DIN 11853-1

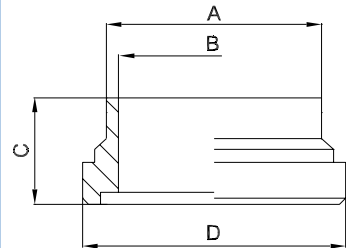

Hygiene Bundstutzen

DIN	pipe	A	B	C	E (Rd)
DN 10	13,0 x 1,5	13,0	10,0	19,0	28 x 1/8"
DN 15	19,0 x 1,5	19,0	16,0	19,0	34 x 1/8"
DN 20	23,0 x 1,5	23,0	20,0	21,0	44 x 1/6"
DN 25	29,0 x 1,5	29,0	26,0	26,0	52 x 1/6"
DN 32	35,0 x 1,5	35,0	32,0	30,0	58 x 1/6"
DN 40	41,0 x 1,5	41,0	38,0	31,0	65 x 1/6"
DN 50	53,0 x 1,5	53,0	50,0	31,0	78 x 1/6"
DN 65	70,0 x 2,0	70,0	66,0	36,0	95 x 1/6"
DN 80	85,0 x 2,0	85,0	81,0	42,0	110 x 1/4"
DN 100	104,0 x 2,0	104,0	100,0	50,0	130 x 1/4"

DIN	pipe	A	B	C	D
DN 10	13,0 x 1,5	13,0	10,0	17,0	21,9
DN 15	19,0 x 1,5	19,0	16,0	17,0	27,9
DN 20	23,0 x 1,5	23,0	20,0	18,0	35,9
DN 25	29,0 x 1,5	29,0	26,0	22,0	42,9
DN 32	35,0 x 1,5	35,0	32,0	25,0	48,9
DN 40	41,0 x 1,5	41,0	38,0	26,0	54,9
DN 50	53,0 x 1,5	53,0	50,0	30,0	66,9
DN 65	70,0 x 2,0	70,0	66,0	34,0	84,9
DN 80	85,0 x 2,0	85,0	81,0	38,0	98,9
DN 100	104,0 x 2,0	104,0	100,0	46,0	118,9

ISO	pipe	A	B	C	E (Rd)
DN 8	13,5 x 1,6	13,5	10,3	19,0	28 x 1/8"
DN 10	17,2 x 1,6	17,2	14,0	19,0	34 x 1/8"
DN 15	21,3 x 1,6	21,3	18,1	21,0	44 x 1/6"
DN 20	26,9 x 1,6	26,9	23,7	26,0	52 x 1/6"
DN 25	33,7 x 2,0	33,7	29,7	30,0	58 x 1/6"
DN 32	42,4 x 2,0	42,4	38,4	31,0	65 x 1/6"
DN 40	48,3 x 2,0	48,3	44,3	31,0	78 x 1/6"
DN 50	60,3 x 2,0	60,3	56,3	36,0	95 x 1/6"
DN 65	76,1 x 2,0	76,1	72,1	42,0	110 x 1/4"
DN 80	88,9 x 2,3	88,9	84,3	50,0	130 x 1/4"
DN 100	114,3 x 2,3	114,3	109,7	50,0	160 x 1/4"

ISO	pipe	A	B	C	D
DN 8	13,5 x 1,6	13,5	10,3	17,0	21,9
DN 10	17,2 x 1,6	17,2	14,0	17,0	27,9
DN 15	21,3 x 1,6	21,3	18,1	18,0	35,9
DN 20	26,9 x 1,6	26,9	23,7	22,0	42,9
DN 25	33,7 x 2,0	33,7	29,7	25,0	84,9
DN 32	42,4 x 2,0	42,4	38,4	26,0	54,9
DN 40	48,3 x 2,0	48,3	44,3	30,0	66,9
DN 50	60,3 x 2,0	60,3	56,3	34,0	84,9
DN 65	76,1 x 2,0	76,1	72,1	38,0	98,9
DN 80	88,9 x 2,3	88,9	84,3	46,0	118,9
DN 100*	114,3 x 2,3	114,3	109,7	46,0	147,9

ASME BPE	pipe	A	B	C	E (Rd)
DN 1/2"	12,7 x 1,65	12,7	9,4	19,0	28 x 1/8"
DN 3/4"	19,05 x 1,65	19,05	15,75	19,0	34 x 1/8"
DN 1"	25,4 x 1,65	25,4	22,1	26,0	52 x 1/6"
DN 1 1/2"	38,1 x 1,65	38,1	34,8	31,0	65 x 1/6"
DN 2"	50,8 x 1,65	50,8	47,5	31,0	78 x 1/6"
DN 2 1/2"	63,5 x 1,65	63,5	60,2	36,0	95 x 1/6"
DN 3"	76,2 x 1,65	76,2	72,9	42,0	110 x 1/4"
DN 4"	101,6 x 2,11	101,6	97,38	50,0	130 x 1/4"

ASME BPE	pipe	A	B	C	D
DN 1/2"	12,7 x 1,65	12,7	9,4	17,0	21,9
DN 3/4"	19,05 x 1,65	19,05	15,75	17,0	27,9
DN 1"	25,4 x 1,65	25,4	22,1	22,0	42,9
DN 1 1/2"	38,1 x 1,65	38,1	34,8	26,0	54,9
DN 2"	50,8 x 1,65	50,8	47,5	30,0	66,9
DN 2 1/2"	63,5 x 1,65	63,5	60,2	34,0	84,9
DN 3"	76,2 x 1,65	76,2	72,9	38,0	98,9
DN 4"	101,6 x 2,11	101,6	97,38	46,0	118,9

*) non-standard

ASEPTIC PROGRAM

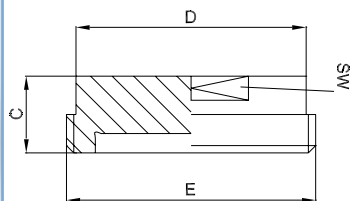
Aseptic blind male part
DIN 11864-1-A a DIN 11853-1

Blindgewindestutzen

DIN	pipe	C	D	E (Rd)	SW
DN 10	13,0 x 1,5	24,0	23,0	28 x 1/8"	19,0
DN 15	19,0 x 1,5	24,0	28,0	34 x 1/8"	24,0
DN 20	23,0 x 1,5	24,0	34,0	44 x 1/6"	30,0
DN 25	29,0 x 1,5	24,0	44,0	52 x 1/6"	41,0
DN 32	35,0 x 1,5	24,0	53,0	58 x 1/6"	46,0
DN 40	41,0 x 1,5	24,0	60,0	65 x 1/6"	50,0
DN 50	53,0 x 1,5	24,0	72,0	78 x 1/6"	65,0
DN 65	70,0 x 2,0	28,0	87,0	95 x 1/6"	80,0
DN 80	85,0 x 2,0	28,0	100,0	110 x 1/4"	95,0
DN 100	104,0 x 2,0	30,0	120,0	130 x 1/4"	115,0

ISO	pipe	C	D	E (Rd)	SW
DN 8	13,5 x 1,6	24,0	23,0	28 x 1/8"	19,0
DN 10	17,2 x 1,6	24,0	28,0	34 x 1/8"	24,0
DN 15	21,3 x 1,6	24,0	34,0	44 x 1/6"	30,0
DN 20	26,9 x 1,6	24,0	44,0	52 x 1/6"	41,0
DN 25	33,7 x 2,0	24,0	54,0	58 x 1/6"	46,0
DN 32	42,4 x 2,0	24,0	60,0	65 x 1/6"	50,0
DN 40	48,3 x 2,0	24,0	72,0	78 x 1/6"	65,0
DN 50	60,3 x 2,0	28,0	87,0	95 x 1/6"	80,0
DN 65	76,1 x 2,0	28,0	100,0	110 x 1/4"	95,0
DN 80	88,9 x 2,3	30,0	120,0	130 x 1/4"	115,0
DN 100	114,3 x 2,3	38,0	150,0	160 x 1/4"	145,0

ASME BPE	pipe	C	D	E (Rd)	SW
DN 1/2"	12,7 x 1,65	54,0	23,0	28 x 1/8"	19,0
DN 3/4"	19,05 x 1,65	24,0	28,0	34 x 1/8"	24,0
DN 1"	25,4 x 1,65	24,0	44,0	52 x 1/6"	41,0
DN 1 1/2"	38,1 x 1,65	24,0	60,0	65 x 1/6"	50,0
DN 2"	50,8 x 1,65	24,0	72,0	78 x 1/6"	65,0
DN 2 1/2"	63,5 x 1,65	28,0	87,0	95 x 1/6"	80,0
DN 3"	76,2 x 1,65	28,0	100,0	110 x 1/4"	95,0
DN 4"	101,6 x 2,11	30,0	120,0	130 x 1/4"	115,0

*) non-standard

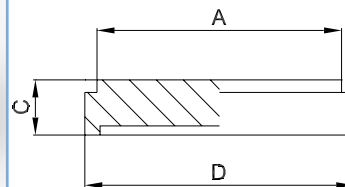
Aseptic blind liner
DIN 11864-1-A a DIN 11853-1

Blindgewindestutzen

DIN	pipe	A	C	D
DN 10	13,0 x 1,5	18,0	9,0	21,9
DN 15	19,0 x 1,5	24,0	9,0	27,9
DN 20	23,0 x 1,5	30,0	10,0	35,9
DN 25	29,0 x 1,5	35,0	12,0	42,9
DN 32	35,0 x 1,5	41,0	13,0	48,9
DN 40	41,0 x 1,5	48,0	13,0	54,9
DN 50	53,0 x 1,5	61,0	14,0	66,9
DN 65	70,0 x 2,0	79,0	16,0	84,9
DN 80	85,0 x 2,0	93,0	16,0	98,9
DN 100	104,0 x 2,0	114,0	20,0	118,9

ISO	pipe	A	C	D
DN 8	13,5 x 1,6	18,0	9,0	21,9
DN 10	17,2 x 1,6	24,0	9,0	27,9
DN 15	21,3 x 1,6	30,0	10,0	35,9
DN 20	26,9 x 1,6	35,0	12,0	42,9
DN 25	33,7 x 2,0	41,0	13,0	48,9
DN 32	42,4 x 2,0	48,0	13,0	54,9
DN 40	48,3 x 2,0	61,0	14,0	66,9
DN 50	60,3 x 2,0	79,0	16,0	84,9
DN 65	76,1 x 2,0	93,0	16,0	98,9
DN 80	88,9 x 2,3	114,0	20,0	118,9
DN 100	114,3 x 2,3	137,0	22,0	147,9

ASME BPE	pipe	A	C	D
DN 1/2"	12,7 x 1,65	18,0	9,0	21,9
DN 3/4"	19,05 x 1,65	24,0	9,0	27,9
DN 1"	25,4 x 1,65	35,0	12,0	42,9
DN 1 1/2"	38,1 x 1,65	48,0	13,0	54,9
DN 2"	50,8 x 1,65	61,0	14,0	66,9
DN 2 1/2"	63,5 x 1,65	79,0	16,0	84,9
DN 3"	76,2 x 1,65	93,0	16,0	98,9
DN 4"	101,6 x 2,11	114,0	20,0	118,9

ASEPTIC PROGRAM

Round nut for aseptic screwed union
DIN 11864-1-A a DIN 11853-1

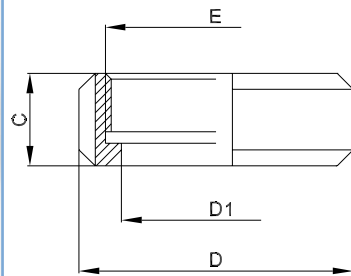

Nutmutter

Seal ring for screwed union
DIN 11864-1-A a DIN 11853-1



Dichtring

DIN	pipe	C	D	D1	E (Rd)
DN 10	13,0 x 1,5	18,0	38,0	19,0	28 x 1/8"
DN 15	19,0 x 1,5	81,0	44,0	25,0	34 x 1/8"
DN 20	23,0 x 1,5	20,0	54,0	31,0	44 x 1/6"
DN 25	29,0 x 1,5	21,0	63,0	36,0	52 x 1/6"
DN 32	35,0 x 1,5	21,0	70,0	42,0	58 x 1/6"
DN 40	41,0 x 1,5	21,0	78,0	49,0	65 x 1/6"
DN 50	53,0 x 1,5	22,0	92,0	62,0	78 x 1/6"
DN 65	70,0 x 2,0	25,0	112,0	80,0	95 x 1/6"
DN 80	85,0 x 2,0	29,0	127,0	94,0	110 x 1/4"
DN 100	104,0 x 2,0	31,0	148,0	115,0	130 x 1/4"

DIN	pipe	dimensions
DN 10	13,0 x 1,5	12 x 3,5
DN 15	19,0 x 1,5	18 x 3,5
DN 20	23,0 x 1,5	22 x 3,5
DN 25	29,0 x 1,5	28 x 3,5
DN 32	35,0 x 1,5	34 x 5,0
DN 40	41,0 x 1,5	40 x 5,0
DN 50	53,0 x 1,5	52 x 5,0
DN 65	70,0 x 2,0	68 x 5,0
DN 80	85,0 x 2,0	83 x 5,0
DN 100	104,0 x 2,0	102 x 2,0

ISO	pipe	C	D	D1	E (Rd)
DN 8	13,5 x 1,6	18,0	38,0	19,0	28 x 1/8"
DN 10	17,2 x 1,6	18,0	44,0	25,0	34 x 1/8"
DN 15	21,3 x 1,6	20,0	54,0	31,0	44 x 1/6"
DN 20	26,9 x 1,6	21,0	63,0	36,0	52 x 1/6"
DN 25	33,7 x 2,0	21,0	70,0	42,0	58 x 1/6"
DN 32	42,4 x 2,0	21,0	78,0	49,0	65 x 1/6"
DN 40	48,3 x 2,0	22,0	92,0	62,0	78 x 1/6"
DN 50	60,3 x 2,0	25,0	112,0	80,0	95 x 1/6"
DN 65	76,1 x 2,0	29,0	127,0	94,0	110 x 1/4"
DN 80	88,9 x 2,3	31,0	148,0	115,0	130 x 1/4"
DN 100	114,3 x 2,3	35,0	178,0	138,0	160 x 1/4"

ISO	pipe	dimensions
DN 8	13,5 x 1,6	12 x 3,5
DN 10	17,2 x 1,6	16 x 3,5
DN 15	21,3 x 1,6	20 x 3,5
DN 20	26,9 x 1,6	26 x 3,5
DN 25	33,7 x 2,0	32 x 5,0
DN 32	42,4 x 2,0	40,5 x 5,0
DN 40	48,3 x 2,0	46,5 x 5,0
DN 50	60,3 x 2,0	58,5 x 5,0
DN 65	76,1 x 2,0	73,5 x 5,0
DN 80	88,9 x 2,3	86,5 x 5,0
DN 100	114,3 x 2,3	111,0 x 5,0

ASME BPE	pipe	C	D	D1	E (Rd)
DN 1/2"	12,7 x 1,65	18,0	38,0	19,0	28 x 1/8"
DN 3/4"	19,05 x 1,65	18,0	44,0	25,0	34 x 1/8"
DN 1"	25,4 x 1,65	21,0	63,0	36,0	52 x 1/6"
DN 1 1/2"	38,1 x 1,65	21,0	78,0	49,0	65 x 1/6"
DN 2"	50,8 x 1,65	22,0	92,0	62,0	78 x 1/6"
DN 2 1/2"	63,5 x 1,65	25,0	112,0	80,0	95 x 1/6"
DN 3"	76,2 x 1,65	29,0	127,0	94,0	110 x 1/4"
DN 4"	101,6 x 2,11	31,0	148,0	115,0	130 x 1/4"

ASME BPE	připojení	pipe
DN 1/2"	12,7 x 1,65	12 x 3,5
DN 3/4"	19,05 x 1,65	18 x 3,5
DN 1"	25,4 x 1,65	24 x 3,5
DN 1 1/2"	38,1 x 1,65	37 x 5,0
DN 2"	50,8 x 1,65	50 x 5,0
DN 2 1/2"	63,5 x 1,65	62 x 5,0
DN 3"	76,2 x 1,65	75 x 5,0
DN 4"	101,6 x 2,11	100,0 x 5,0

*) non-standard