

ASEPTIC PROGRAM



Steril Clampverbindung DIN 11864-3-A

Aseptic CLAMP complete connection DIN 11864-3-A

Dimensions:

DIN 11866-A (DIN 11850)
DIN 11866-B (EN ISO 1127)
DIN 11866-C (ASME BPE)

Marking:

dimension, material, heat number

Tolerance:

DIN 11864 / ISO 2768-1

Material:

AISI 316L at medium contact surface
AISI 304 objímka Clamp
EPDM seal (standard), other materials on demand

Certificate (on demand):

EN 10204 3.1
EN 10204 3.1 AD-W2 (for selected items)

Standard surface („MB“):

inside: $Ra \leq 0,8 \mu m$
outside: $Ra \leq 1,6 \mu m$

Inner surface variants:

electrochemical polished
 $Ra \leq 0,6 \mu m$ (STERI-line®)
 $Ra \leq 0,5 \mu m$ (STERI-line®)
 $Ra \leq 0,4 \mu m$ (HQ-line®)
 $Ra \leq 0,25 \mu m$ (HQ-line®)

DIN	pipe	A	B	C	E
DN 10*	12,0 x 1,0	12,0	10,0	76,0	Ø 34,0
DN 10	13,0 x 1,5	13,0	10,0	76,0	Ø 34,0
DN 15	19,0 x 1,5	19,0	16,0	76,0	Ø 34,0
DN 20	23,0 x 1,5	23,0	20,0	76,0	Ø 50,5
DN 25	29,0 x 1,5	29,0	26,0	77,0	Ø 50,5
DN 32	35,0 x 1,5	35,0	32,0	88,0	Ø 50,5
DN 40	41,0 x 1,5	41,0	38,0	88,0	Ø 64,0
DN 50	53,0 x 1,5	53,0	50,0	89,0	Ø 77,5
DN 65	70,0 x 2,0	70,0	66,0	113,0	Ø 91,0
DN 80	85,0 x 2,0	85,0	81,0	117,0	Ø 106,0
DN 100	104,0 x 2,0	104,0	100,0	120,0	Ø 130,0
DN 125*	129,0 x 2,0	129,0	125,0	120,0	Ø 155,0
DN 150*	154,0 x 2,0	154,0	150,0	120,0	Ø 183,0

ISO	pipe	A	B	C	E
DN 8	13,5 x 1,6	13,5	10,3	76,0	Ø 34,0
DN 10	17,2 x 1,6	17,2	14,0	76,0	Ø 34,0
DN 15	21,3 x 1,6	21,3	18,1	78,0	Ø 34,0
DN 20	26,9 x 1,6	26,9	23,7	78,0	Ø 50,5
DN 25	33,7 x 2,0	33,7	29,7	88,0	Ø 50,5
DN 32	42,4 x 2,0	42,4	38,4	88,0	Ø 64,0
DN 40	48,3 x 2,0	48,3	44,3	90,0	Ø 64,0
DN 50	60,3 x 2,0	60,3	56,3	114,0	Ø 91,0
DN 65	76,1 x 2,0	76,1	72,1	117,0	Ø 106,0
DN 80	88,9 x 2,3	88,9	84,3	122,0	Ø 119,0
DN 100*	114,3 x 2,3	114,3	109,7	130,0	Ø 144,4
DN 125*	139,7 x 2,6	139,7	134,5	120,0	Ø 155,0
DN 150*	168,3 x 2,6	168,3	163,1	120,0	Ø 183,0
DN 200*	219,1 x 2,6	219,1	213,9	120,0	Ø 233,5

*) non-standard

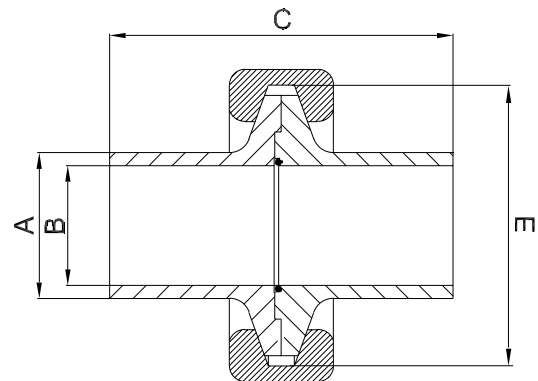

ASME BPE	pipe	A	B	C	E
DN 1/2"	12,7 x 1,65	12,7	9,4	76,0	Ø 34,0
DN 3/4"	19,05 x 1,65	19,05	15,75	76,0	Ø 34,0
DN 1"	25,4 x 1,65	25,4	22,1	77,0	Ø 50,5
DN 1 1/2"	38,1 x 1,65	38,1	34,8	88,0	Ø 64,0
DN 2"	50,8 x 1,65	50,8	47,5	89,0	Ø 77,5
DN 2 1/2"	63,5 x 1,65	63,5	60,2	115,0	Ø 91,0
DN 3"	76,2 x 1,65	76,2	72,9	117,0	Ø 106,0
DN 4"	101,6 x 2,11	101,6	97,38	119,0	Ø 130,0

ASEPTIC PROGRAM



Hygiene Clampverbindung DIN 11853-3

Hygienic CLAMP complete connection DIN 11853-3

Dimensions:

DIN 11866-A (DIN 11850)
DIN 11866-B (EN ISO 1127)
DIN 11866-C (ASME BPE)

Marking:

dimension, material, heat number

Tolerance:

DIN 11853 / ISO 2768-1

Material:

AISI 316L at medium contact surface
AISI 304 objímka Clamp
EPDM seal (standard), other materials on demand

Certificate (on demand):

EN 10204 3.1
EN 10204 3.1 AD-W2 (for selected items)

Standard surface („MB“):

inside: $Ra \leq 0,8 \mu m$
outside: $Ra \leq 1,6 \mu m$

Inner surface variants:

electrochemical polished
 $Ra \leq 0,6 \mu m$ (STERI-line®)
 $Ra \leq 0,5 \mu m$ (STERI-line®)
 $Ra \leq 0,4 \mu m$ (HQ-line®)
 $Ra \leq 0,25 \mu m$ (HQ-line®)

DIN	pipe	A	B	C	E
DN 10	13,0 x 1,5	13,0	10,0	44,0	Ø 34,0
DN 15	19,0 x 1,5	19,0	16,0	44,0	Ø 34,0
DN 20	23,0 x 1,5	23,0	20,0	44,0	Ø 50,5
DN 25	29,0 x 1,5	29,0	26,0	44,0	Ø 50,5
DN 32	35,0 x 1,5	35,0	32,0	48,0	Ø 50,5
DN 40	41,0 x 1,5	41,0	38,0	48,0	Ø 64,0
DN 50	53,0 x 1,5	53,0	50,0	49,0	Ø 77,5
DN 65	70,0 x 2,0	70,0	66,0	53,0	Ø 91,0
DN 80	85,0 x 2,0	85,0	81,0	57,0	Ø 106,0
DN 100	104,0 x 2,0	104,0	100,0	60,0	Ø 130,0
DN 125*	129,0 x 2,0	129,0	125,0	60,0	Ø 155,0
DN 150*	154,0 x 2,0	154,0	150,0	60,0	Ø 183,0
DN 200*	204,0 x 2,0	204,0	200,0	60,0	Ø 233,5

ISO	pipe	A	B	C	E
DN 8	13,5 x 1,6	13,5	10,3	44,0	Ø 34,0
DN 10	17,2 x 1,6	17,2	14,0	44,0	Ø 34,0
DN 15	21,3 x 1,6	21,3	18,1	44,0	Ø 34,0
DN 20	26,9 x 1,6	26,9	23,7	44,0	Ø 50,5
DN 25	33,7 x 2,0	33,7	29,7	48,0	Ø 50,5
DN 32	42,4 x 2,0	42,4	38,4	48,0	Ø 64,0
DN 40	48,3 x 2,0	48,3	44,3	50,0	Ø 64,0
DN 50	60,3 x 2,0	60,3	56,3	54,0	Ø 91,0
DN 65	76,1 x 2,0	76,1	72,1	57,0	Ø 106,0
DN 80	88,9 x 2,3	88,9	84,3	62,0	Ø 119,0
DN 100*	114,3 x 2,3	114,3	109,7	62,0	Ø 144,4

*) non-standard

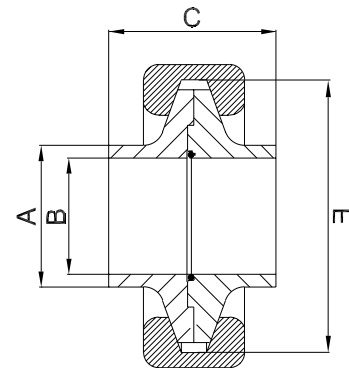

ASME BPE	pipe	A	B	C	E
DN 1/2"	12,7 x 1,65	12,7	9,4	44,0	Ø 34,0
DN 3/4"	19,05 x 1,65	19,05	15,75	44,0	Ø 34,0
DN 1"	25,4 x 1,65	25,4	22,1	44,0	Ø 50,5
DN 1 1/2"	38,1 x 1,65	38,1	34,8	48,0	Ø 64,0
DN 2"	50,8 x 1,65	50,8	47,5	49,0	Ø 77,5
DN 2 1/2"	63,5 x 1,65	63,5	60,2	55,0	Ø 91,0
DN 3"	76,2 x 1,65	76,2	72,9	57,0	Ø 106,0
DN 4"	101,6 x 2,11	101,6	97,38	59,0	Ø 130,0

ASEPTIC PROGRAM

Aseptic Clamp with groove DIN 11864-3-A:

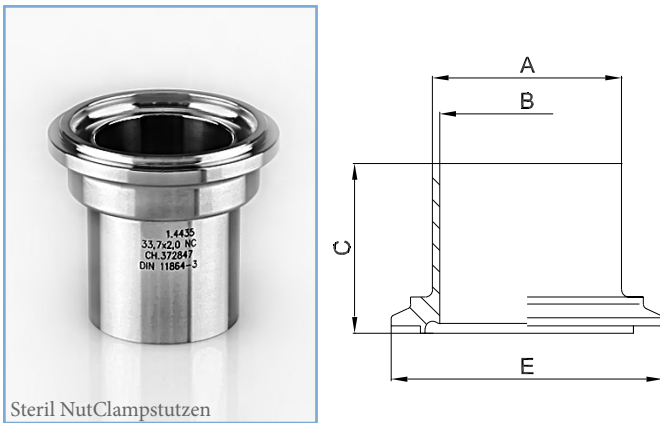

Aseptic Clamp with collar DIN 11864-3-A:

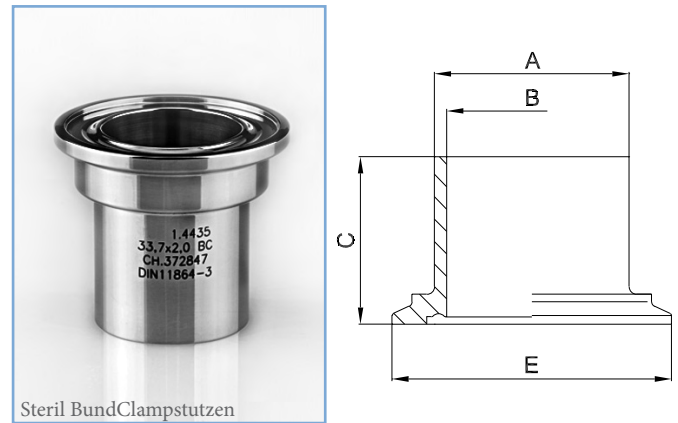

DIN	pipe	A	B	C	E
DN 10*	12,0 x 1,0	12,0	10,0	39,5	Ø 34,0
DN 10	13,0 x 1,5	13,0	10,0	39,5	Ø 34,0
DN 15	19,0 x 1,5	19,0	16,0	39,5	Ø 34,0
DN 20	23,0 x 1,5	23,0	20,0	39,5	Ø 50,5
DN 25	29,0 x 1,5	29,0	26,0	40,0	Ø 50,5
DN 32	35,0 x 1,5	35,0	32,0	45,5	Ø 50,5
DN 40	41,0 x 1,5	41,0	38,0	45,5	Ø 64,0
DN 50	53,0 x 1,5	53,0	50,0	46,0	Ø 77,5
DN 65	70,0 x 2,0	70,0	66,0	58,0	Ø 91,0
DN 80	85,0 x 2,0	85,0	81,0	60,0	Ø 106,0
DN 100	104,0 x 2,0	104,0	100,0	61,5	Ø 130,0
DN 125*	129,0 x 2,0	129,0	125,0	61,5	Ø 155,0
DN 150*	154,0 x 2,0	154,0	150,0	61,5	Ø 183,0

DIN	pipe	A	B	C	E
DN 10*	12,0 x 1,0	12,0	10,0	38,0	Ø 34,0
DN 10	13,0 x 1,5	13,0	10,0	38,0	Ø 34,0
DN 15	19,0 x 1,5	19,0	16,0	38,0	Ø 34,0
DN 20	23,0 x 1,5	23,0	20,0	38,0	Ø 50,5
DN 25	29,0 x 1,5	29,0	26,0	38,5	Ø 50,5
DN 32	35,0 x 1,5	35,0	32,0	44,0	Ø 50,5
DN 40	41,0 x 1,5	41,0	38,0	44,0	Ø 64,0
DN 50	53,0 x 1,5	53,0	50,0	44,5	Ø 77,5
DN 65	70,0 x 2,0	70,0	66,0	56,5	Ø 91,0
DN 80	85,0 x 2,0	85,0	81,0	58,5	Ø 106,0
DN 100	104,0 x 2,0	104,0	100,0	60,0	Ø 130,0
DN 125*	129,0 x 2,0	129,0	125,0	60,0	Ø 155,0
DN 150*	154,0 x 2,0	154,0	150,0	60,0	Ø 183,0

ISO	pipe	A	B	C	E
DN 8	13,5 x 1,6	13,5	10,3	39,5	Ø 34,0
DN 10	17,2 x 1,6	17,2	14,0	39,5	Ø 34,0
DN 15	21,3 x 1,6	21,3	18,1	40,5	Ø 34,0
DN 20	26,9 x 1,6	26,9	23,7	40,5	Ø 50,5
DN 25	33,7 x 2,0	33,7	29,7	45,5	Ø 50,5
DN 32	42,4 x 2,0	42,4	38,4	45,5	Ø 64,0
DN 40	48,3 x 2,0	48,3	44,3	46,5	Ø 64,0
DN 50	60,3 x 2,0	60,3	56,3	58,5	Ø 91,0
DN 65	76,1 x 2,0	76,1	72,1	60,0	Ø 106,0
DN 80	88,9 x 2,3	88,9	84,3	62,5	Ø 119,0
DN 100*	114,3 x 2,3	114,3	109,7	66,5	Ø 144,4
DN 125*	139,7 x 2,6	139,7	134,5	61,5	Ø 155,0
DN 150*	168,3 x 2,6	168,3	163,1	61,5	Ø 183,0
DN 200*	219,1 x 2,6	219,1	213,9	61,5	Ø 233,5

ISO	pipe	A	B	C	E
DN 8	13,5 x 1,6	13,5	10,3	38,0	Ø 34,0
DN 10	17,2 x 1,6	17,2	14,0	38,0	Ø 34,0
DN 15	21,3 x 1,6	21,3	18,1	39,0	Ø 34,0
DN 20	26,9 x 1,6	26,9	23,7	39,0	Ø 50,5
DN 25	33,7 x 2,0	33,7	29,7	44,0	Ø 50,5
DN 32	42,4 x 2,0	42,4	38,4	44,0	Ø 64,0
DN 40	48,3 x 2,0	48,3	44,3	45,0	Ø 64,0
DN 50	60,3 x 2,0	60,3	56,3	57,0	Ø 91,0
DN 65	76,1 x 2,0	76,1	72,1	58,5	Ø 106,0
DN 80	88,9 x 2,3	88,9	84,3	61,0	Ø 119,0
DN 100*	114,3 x 2,3	114,3	109,7	65,0	Ø 144,4
DN 125*	139,7 x 2,6	139,7	134,5	60,0	Ø 155,0
DN 150*	168,3 x 2,6	168,3	163,1	60,0	Ø 183,0
DN 200*	219,1 x 2,6	219,1	213,9	60,0	Ø 233,5

ASME	pipe	A	B	C	E
DN 1/2"	12,7 x 1,65	12,7	9,4	39,5	Ø 34,0
DN 3/4"	19,05 x 1,65	19,05	15,75	39,5	Ø 34,0
DN 1"	25,4 x 1,65	25,4	22,1	40,0	Ø 50,5
DN 1 1/2"	38,1 x 1,65	38,1	34,8	45,5	Ø 64,0
DN 2"	50,8 x 1,65	50,8	47,5	46,0	Ø 77,5
DN 2 1/2"	63,5 x 1,65	63,5	60,2	59,0	Ø 91,0
DN 3"	76,2 x 1,65	76,2	72,9	60,0	Ø 106,0
DN 4"	101,6 x 2,11	101,6	97,38	61,0	Ø 130,0

ASME	pipe	A	B	C	E
DN 1/2"	12,7 x 1,65	12,7	9,4	38,0	Ø 34,0
DN 3/4"	19,05 x 1,65	19,05	15,75	38,0	Ø 34,0
DN 1"	25,4 x 1,65	25,4	22,1	38,5	Ø 50,5
DN 1 1/2"	38,1 x 1,65	38,1	34,8	44,0	Ø 64,0
DN 2"	50,8 x 1,65	50,8	47,5	44,5	Ø 77,5
DN 2 1/2"	63,5 x 1,65	63,5	60,2	57,5	Ø 91,0
DN 3"	76,2 x 1,65	76,2	72,9	58,5	Ø 106,0
DN 4"	101,6 x 2,11	101,6	97,38	59,5	Ø 130,0

*) non-standard

ASEPTIC PROGRAM

Hygienic Clamp with groove DIN 11853-3:

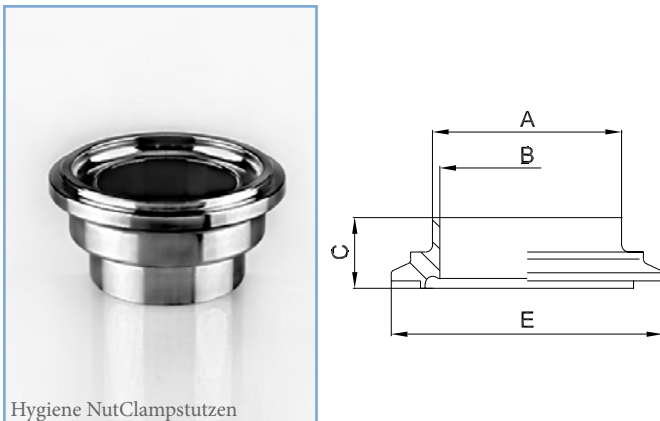

Hygiene Nut Clampstutzen

Hygienic Clamp with collar DIN 11853-3:

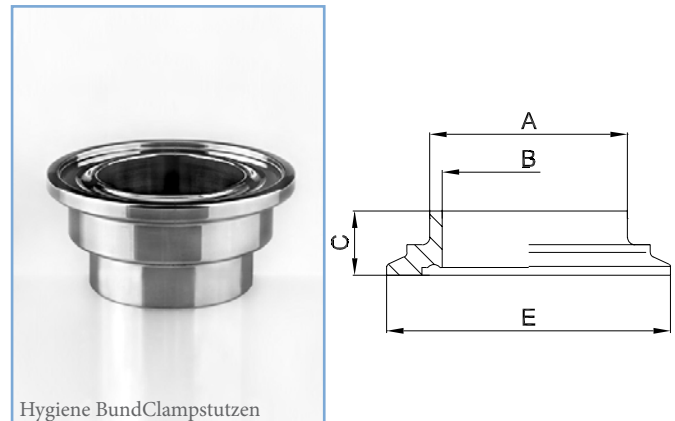

Hygiene Bund Clampstutzen

DIN	pipe	A	B	C	E
DN 10	13,0 x 1,5	13,0	10,0	23,5	Ø 34,0
DN 15	19,0 x 1,5	19,0	16,0	23,5	Ø 34,0
DN 20	23,0 x 1,5	23,0	20,0	23,5	Ø 50,5
DN 25	29,0 x 1,5	29,0	26,0	23,5	Ø 50,5
DN 32	35,0 x 1,5	35,0	32,0	25,5	Ø 50,5
DN 40	41,0 x 1,5	41,0	38,0	25,5	Ø 64,0
DN 50	53,0 x 1,5	53,0	50,0	26,0	Ø 77,5
DN 65	70,0 x 2,0	70,0	66,0	28,0	Ø 91,0
DN 80	85,0 x 2,0	85,0	81,0	30,0	Ø 106,0
DN 100	104,0 x 2,0	104,0	100,0	31,5	Ø 130,0
DN 125*	129,0 x 2,0	129,0	125,0	31,5	Ø 155,0
DN 150*	154,0 x 2,0	154,0	150,0	31,5	Ø 183,0
DN 200*	204,0 x 2,0	204,0	200,0	31,5	Ø 233,5

DIN	pipe	A	B	C	E
DN 10	13,0 x 1,5	13,0	10,0	22,0	Ø 34,0
DN 15	19,0 x 1,5	19,0	16,0	22,0	Ø 34,0
DN 20	23,0 x 1,5	23,0	20,0	22,0	Ø 50,5
DN 25	29,0 x 1,5	29,0	26,0	22,0	Ø 50,5
DN 32	35,0 x 1,5	35,0	32,0	24,0	Ø 50,5
DN 40	41,0 x 1,5	41,0	38,0	24,0	Ø 64,0
DN 50	53,0 x 1,5	53,0	50,0	24,5	Ø 77,5
DN 65	70,0 x 2,0	70,0	66,0	26,5	Ø 91,0
DN 80	85,0 x 2,0	85,0	81,0	28,5	Ø 106,0
DN 100	104,0 x 2,0	104,0	100,0	30,0	Ø 130,0
DN 125*	129,0 x 2,0	129,0	125,0	30,0	Ø 155,0
DN 150*	154,0 x 2,0	154,0	150,0	30,0	Ø 183,0
DN 200*	204,0 x 2,0	204,0	200,0	30,0	Ø 233,5

ISO	pipe	A	B	C	E
DN 8	13,5 x 1,6	13,5	10,3	23,5	Ø 34,0
DN 10	17,2 x 1,6	17,2	14,0	23,5	Ø 34,0
DN 15	21,3 x 1,6	21,3	18,1	23,5	Ø 34,0
DN 20	26,9 x 1,6	26,9	23,7	23,5	Ø 50,5
DN 25	33,7 x 2,0	33,7	29,7	25,5	Ø 50,5
DN 32	42,4 x 2,0	42,4	38,4	25,5	Ø 64,0
DN 40	48,3 x 2,0	48,3	44,3	26,5	Ø 64,0
DN 50	60,3 x 2,0	60,3	56,3	28,5	Ø 91,0
DN 65	76,1 x 2,0	76,1	72,1	30,0	Ø 106,0
DN 80	88,9 x 2,3	88,9	84,3	32,5	Ø 119,0
DN 100*	114,3 x 2,3	114,3	109,7	32,5	Ø 144,4

ISO	pipe	A	B	C	E
DN 8	13,5 x 1,6	13,5	10,3	22,0	Ø 34,0
DN 10	17,2 x 1,6	17,2	14,0	22,0	Ø 34,0
DN 15	21,3 x 1,6	21,3	18,1	22,0	Ø 34,0
DN 20	26,9 x 1,6	26,9	23,7	22,0	Ø 50,5
DN 25	33,7 x 2,0	33,7	29,7	24,0	Ø 50,5
DN 32	42,4 x 2,0	42,4	38,4	24,0	Ø 64,0
DN 40	48,3 x 2,0	48,3	44,3	25,0	Ø 64,0
DN 50	60,3 x 2,0	60,3	56,3	27,0	Ø 91,0
DN 65	76,1 x 2,0	76,1	72,1	28,5	Ø 106,0
DN 80	88,9 x 2,3	88,9	84,3	31,0	Ø 119,0
DN 100*	114,3 x 2,3	114,3	109,7	31,0	Ø 144,4

ASME	pipe	A	B	C	E
DN 1/2"	12,7 x 1,65	12,7	9,4	23,5	Ø 34,0
DN 3/4"	19,05 x 1,65	19,05	15,75	23,5	Ø 34,0
DN 1"	25,4 x 1,65	25,4	22,1	23,5	Ø 50,5
DN 1 1/2"	38,1 x 1,65	38,1	34,8	25,5	Ø 64,0
DN 2"	50,8 x 1,65	50,8	47,5	26,0	Ø 77,5
DN 2 1/2"	63,5 x 1,65	63,5	60,2	29,0	Ø 91,0
DN 3"	76,2 x 1,65	76,2	72,9	30,0	Ø 106,0
DN 4"	101,6 x 2,11	101,6	97,38	31,0	Ø 130,0

ASME	pipe	A	B	C	E
DN 1/2"	12,7 x 1,65	12,7	9,4	22,0	Ø 34,0
DN 3/4"	19,05 x 1,65	19,05	15,75	22,0	Ø 34,0
DN 1"	25,4 x 1,65	25,4	22,1	22,0	Ø 50,5
DN 1 1/2"	38,1 x 1,65	38,1	34,8	24,0	Ø 64,0
DN 2"	50,8 x 1,65	50,8	47,5	24,5	Ø 77,5
DN 2 1/2"	63,5 x 1,65	63,5	60,2	27,5	Ø 91,0
DN 3"	76,2 x 1,65	76,2	72,9	28,5	Ø 106,0
DN 4"	101,6 x 2,11	101,6	97,38	29,5	Ø 130,0

*) non-standard

ASEPTIC PROGRAM

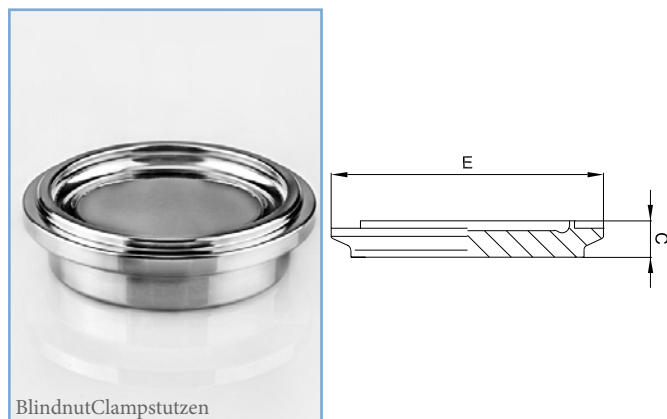
Aseptic Clamp with groove
DIN 11864-1-A and DIN 11853-1

BlindnutClampstutzen

DIN	pipe	C	E
DN 10	13,0 x 1,5	13,0	Ø 34,0
DN 15	19,0 x 1,5	13,0	Ø 34,0
DN 20	23,0 x 1,5	13,0	Ø 50,5
DN 25	29,0 x 1,5	13,0	Ø 50,5
DN 32	35,0 x 1,5	13,0	Ø 50,5
DN 40	41,0 x 1,5	13,0	Ø 64,0
DN 50	53,0 x 1,5	15,0	Ø 77,5
DN 65	70,0 x 2,0	15,0	Ø 91,0
DN 80	85,0 x 2,0	15,0	Ø 106,0
DN 100	104,0 x 2,0	15,0	Ø 130,0
DN 125*	129,0 x 2,0	17,0	Ø 155,0
DN 150*	154,0 x 2,0	17,0	Ø 183,0

ISO	pipe	C	E
DN 8	13,5 x 1,6	13,0	Ø 34,0
DN 10	17,2 x 1,6	13,0	Ø 34,0
DN 15	21,3 x 1,6	13,0	Ø 34,0
DN 20	26,9 x 1,6	13,0	Ø 50,5
DN 25	33,7 x 2,0	13,0	Ø 50,5
DN 32	42,4 x 2,0	13,0	Ø 64,0
DN 40	48,3 x 2,0	13,0	Ø 64,0
DN 50	60,3 x 2,0	15,0	Ø 91,0
DN 65	76,1 x 2,0	15,0	Ø 106,0
DN 80	88,9 x 2,3	15,0	Ø 119,0
DN 100*	114,3 x 2,3	15,0	Ø 144,4
DN 125*	139,7 x 2,6	17,0	Ø 155,0
DN 150*	168,3 x 2,6	17,0	Ø 183,0
DN 200*	219,1 x 2,6	17,0	Ø 233,5

ASME	pipe	C	E
DN 1/2"	12,7 x 1,65	13,0	Ø 34,0
DN 3/4"	19,05 x 1,65	13,0	Ø 34,0
DN 1"	25,4 x 1,65	13,0	Ø 50,5
DN 1 1/2"	38,1 x 1,65	13,0	Ø 64,0
DN 2"	50,8 x 1,65	15,0	Ø 77,5
DN 2 1/2"	63,5 x 1,65	15,0	Ø 91,0
DN 3"	76,2 x 1,65	15,0	Ø 106,0
DN 4"	101,6 x 2,11	15,0	Ø 130,0

*) non-standard

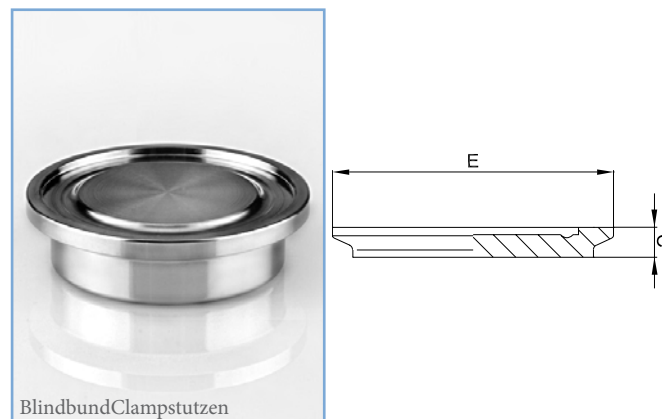
Aseptic Clamp with collar
DIN 11864-1-A a DIN 11853-1

BlindbundClampstutzen

DIN	pipe	C	E
DN 10	13,0 x 1,5	11,5	Ø 34,0
DN 15	19,0 x 1,5	11,5	Ø 34,0
DN 20	23,0 x 1,5	11,5	Ø 50,5
DN 25	29,0 x 1,5	11,5	Ø 50,5
DN 32	35,0 x 1,5	11,5	Ø 50,5
DN 40	41,0 x 1,5	11,5	Ø 64,0
DN 50	53,0 x 1,5	13,5	Ø 77,5
DN 65	70,0 x 2,0	13,5	Ø 91,0
DN 80	85,0 x 2,0	13,5	Ø 106,0
DN 100	104,0 x 2,0	13,5	Ø 130,0
DN 125*	129,0 x 2,0	15,5	Ø 155,0
DN 150*	154,0 x 2,0	15,5	Ø 183,0

ISO	pipe	C	E
DN 8	13,5 x 1,6	11,5	Ø 34,0
DN 10	17,2 x 1,6	11,5	Ø 34,0
DN 15	21,3 x 1,6	11,5	Ø 34,0
DN 20	26,9 x 1,6	11,5	Ø 50,5
DN 25	33,7 x 2,0	11,5	Ø 50,5
DN 32	42,4 x 2,0	11,5	Ø 64,0
DN 40	48,3 x 2,0	11,5	Ø 64,0
DN 50	60,3 x 2,0	13,5	Ø 91,0
DN 65	76,1 x 2,0	13,5	Ø 106,0
DN 80	88,9 x 2,3	13,5	Ø 119,0
DN 100*	114,3 x 2,3	13,5	Ø 144,4
DN 125*	139,7 x 2,6	15,5	Ø 155,0
DN 150*	168,3 x 2,6	15,5	Ø 183,0
DN 200*	219,1 x 2,6	15,5	Ø 233,5

ASME	pipe	C	E
DN 1/2"	12,7 x 1,65	11,5	Ø 34,0
DN 3/4"	19,05 x 1,65	11,5	Ø 34,0
DN 1"	25,4 x 1,65	11,5	Ø 50,5
DN 1 1/2"	38,1 x 1,65	11,5	Ø 64,0
DN 2"	50,8 x 1,65	13,5	Ø 77,5
DN 2 1/2"	63,5 x 1,65	13,5	Ø 91,0
DN 3"	76,2 x 1,65	13,5	Ø 106,0
DN 4"	101,6 x 2,11	13,5	Ø 130,0

ASEPTIC PROGRAM

Heavy duty Clamp for CLAMP connection



Clampklammer
type: single pin

diam.	D	press. [bar]*	diam.	D	press. [bar]*
Ø 25,0	28,0	15	Ø 106,0	109,2	10
Ø 34,0	37,0	15	Ø 119,0	122,2	10
Ø 50,5	53,6	15	Ø 130,0	133,2	5
Ø 64,0	67,0	15	Ø 144,4	148,2	5
Ø 77,5	80,6	15	Ø 167,0	170,0	5
Ø 91,0	94,2	10	Ø 183,0	187,0	5

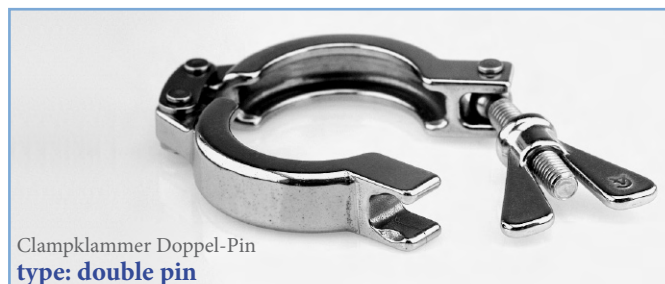

Clampklammer Doppel-Pin
type: double pin

press.	D	press. [bar]*	diam.	D	press. [bar]*
Ø 25,0	28,0	20	Ø 119,0	122,0	14
Ø 34,0	37,0	20	Ø 130,0	133,0	13
Ø 50,5	53,0	20	Ø 144,4	147,0	12
Ø 64,0	67,0	20	Ø 183,0	187,0	10
Ø 77,5	80,0	20	Ø 233,5	238,0	10
Ø 91,0	94,0	19	Ø 268,0	272,0	5
Ø 106,0	109,0	17	Ø 319,0	322,0	2



Clampklammer mit Sechskantmutter
type: SSH (with hex. nut)

diam.	D	press. [bar]*
Ø 25,0	28,0	80
Ø 34,0	37,0	80
Ø 50,5	52,0	80
Ø 64,0	65,5	55
Ø 77,5	79,0	50
Ø 91,0	92,5	45
Ø 106,0	109,0	40
Ø 119,0	122,0	40

*) working press. at max 150 °C

Aseptic seal ring for CLAMP connection DIN 11864-1-A and DIN 11853-1



Steril Dichtring

DIN	pipe	dimensions
DN 10	13,0 x 1,5	12 x 3,5
DN 15	19,0 x 1,5	18 x 3,5
DN 20	23,0 x 1,5	22 x 3,5
DN 25	29,0 x 1,5	28 x 3,5
DN 32	35,0 x 1,5	34 x 5,0
DN 40	41,0 x 1,5	40 x 5,0
DN 50	53,0 x 1,5	52 x 5,0
DN 65	70,0 x 2,0	68 x 5,0
DN 80	85,0 x 2,0	83 x 5,0
DN 100	104,0 x 2,0	102 x 2,0

ISO	pipe	dimensions
DN 8	13,5 x 1,6	12 x 3,5
DN 10	17,2 x 1,6	16 x 3,5
DN 15	21,3 x 1,6	20 x 3,5
DN 20	26,9 x 1,6	26 x 3,5
DN 25	33,7 x 2,0	32 x 5,0
DN 32	42,4 x 2,0	40,5 x 5,0
DN 40	48,3 x 2,0	46,5 x 5,0
DN 50	60,3 x 2,0	58,5 x 5,0
DN 65	76,1 x 2,0	73,5 x 5,0
DN 80	88,9 x 2,3	86,5 x 5,0
DN 100	114,3 x 2,3	111,0 x 5,0

ASME BPE	pipe	dimensions
DN 1/2"	12,7 x 1,65	12 x 3,5
DN 3/4"	19,05 x 1,65	18 x 3,5
DN 1"	25,4 x 1,65	24 x 3,5
DN 1 1/2"	38,1 x 1,65	37 x 5,0
DN 2"	50,8 x 1,65	50 x 5,0
DN 2 1/2"	63,5 x 1,65	62 x 5,0
DN 3"	76,2 x 1,65	75 x 5,0
DN 4"	101,6 x 2,11	100,0 x 5,0

*) non-standard