

RESILIENT SEAT GATE VALVE PN10-16 F5

O^oGATE

armat
spol. s r.o.
MADE OF STAINLESS ...



ISO 9001 : 2008

WRAS
APPROVED
PRODUCT

Certificate 3.1



Size : DN 40 to DN 600
Ends : Flanges PN10/16
Min Temperature : - 10°C
Max Temperature : + 70°C
Max Pressure : 16 Bars up to DN400, 10 bars over
Specifications : Non rising stem
Clockwise to close
Full and total bore

Materials : Ductile iron body

RESILIENT SEAT GATE VALVE PN10-16 F5

SPECIFICATIONS :

Full and total bore
 Stainless steel non rising stem
 Clockwise to close
 Sliding pad (to facilitating the wedge movement) up to DN200
 Ductile iron wedge EPDM coated
 No retention area
 Heel positioning
 NBR bonnet gasket
 Screws bonnet protected
 3 NBR O ring on stem
 Possibility to change stem gasket under pressure from DN80 to 600
 Epoxy painting RAL 5005 color 250 µm thickness
 Dust-coat on stem
 PN10/16 flanges R.F.
 With square drive nut

USE :

For water distribution
 Min and max Temperature Ts : - 10°C to + 70°C
 Max pressure Ps : 16 bars for PN16 flanged valves up to DN400
 Max pressure Ps : 10 bars for PN10 flanged valves from DN200 to 600

FLOW COEFFICIENT Kvs (M3 / h) :

DN	40	50	65	80	100	125	150	200
Kvs (m3/h)	118	229	360	537	933	1595	2685	5004

DN	250	300	350	400	450	500	600
Kvs (m3/h)	8393	12072	16348	21528	29372	37117	52626

HEAD LOSS CALCULATION FOR WATER :

$$\Delta p = (Q / Kvs)^2$$

Q : flow in m³/h

Δp : Head loss in bar

TORQUE VALUE (in Nm without safety coefficient) :

DN	40	50	65	80	100	125	150	200	250	300
Torque (Nm)	15	20	20	30	40	40	75	125	175	200

DN	350	400	450	500	600
Torque (Nm)	325	350	430	460	480

RESILIENT SEAT GATE VALVE PN10-16 F5

NUMBER OF CYCLES TO CLOSE OR OPEN THE VALVE :

DN	40	50	65	80	100	125	150	200	250	300
Number of cycles	13	14.5	18.75	21.5	21.5	24.5	30	34	45.25	49.75

DN	350	400	450	500	600
Number of cycles	55	61	52	57	66

RESILIENT SEAT GATE VALVE PN10-16 F5

O^oGATE

RANGE :

Ductile iron body flanged R.F. PN10/16 with square drive nut and ductile iron wedge EPDM coated **Ref. 184** from DN 40 to 600

ACCESSORIES :



Possible with handwheel (option) **Ref. 9801594-9801598** from DN40 to DN400



Stem extension 1 meter long **Ref. 9802020** from DN50 to DN300 and **Ref. 9802029** from DN350 to DN400



Stem extension 1,25 meter long **Ref. 9802031** from DN50 to DN300 and **Ref. 9802040** from DN350 to DN400



Stem extension 1,5 meter long **Ref. 9802042** from DN50 to DN300 and **Ref. 9802051** from DN350 to DN400



Stem extension 1,3 to 1,8 meter long **Ref. 9802060** from DN50 to DN200



Stem extension 2 to 2,5 meter long **Ref. 9802070** from DN50 to DN200

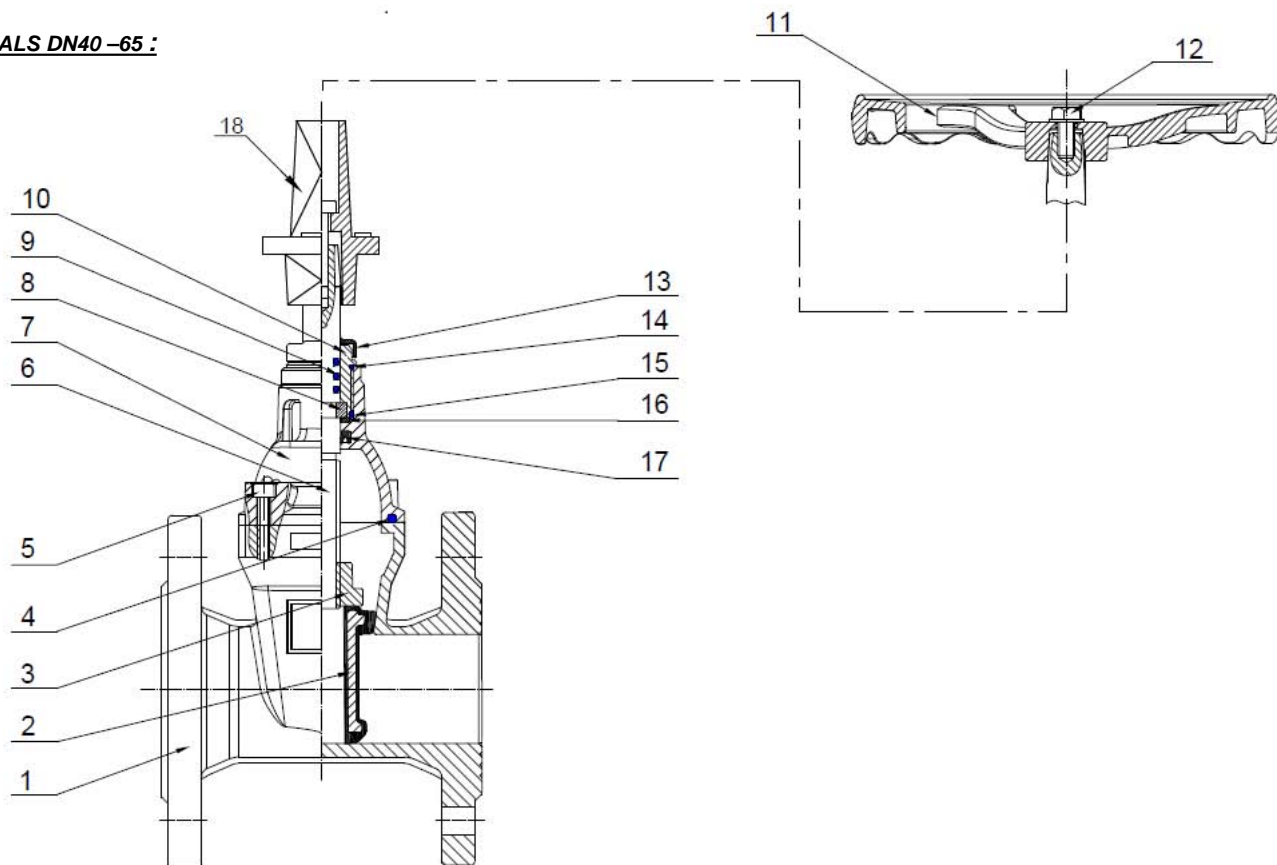

Tee key 1 meter long **Ref.9802080** from DN50 to 200, **Ref.9802081** from DN250 to DN300 and **Ref. 9802082** from DN350 to DN400

RESILIENT SEAT GATE VALVE PN10-16 F5
O^oGATE
MATERIALS DN40 -65 :

Item	Designation	Materials
1	Body	Ductile iron EN GJS-500-7
2	Wedge	Ductile iron EN GJS-500-7 EPDM coated
3	Stem nut	Brass CuZn39Pb2
4	Bonnet gasket	NBR
5	Bonnet screw	C35
6	Stem	SS 420
7	Bonnet	Ductile iron EN GJS-500-7
8	Holding ring	Brass CuZn39Pb2
9	Stem O ring	NBR
10	Nut	Brass CuZn39Pb2
11	Handwheel	Ductile iron EN GJS-500-7
12	Handwheel screw	SS 304
13	Dust-coat	NBR
14	Stem O ring	NBR
15	Stem O ring	NBR
16	Ring	Nylon 66
17	Auto sealing ring	NBR
18	Square drive nut	Ductile iron EN GJS-500-7

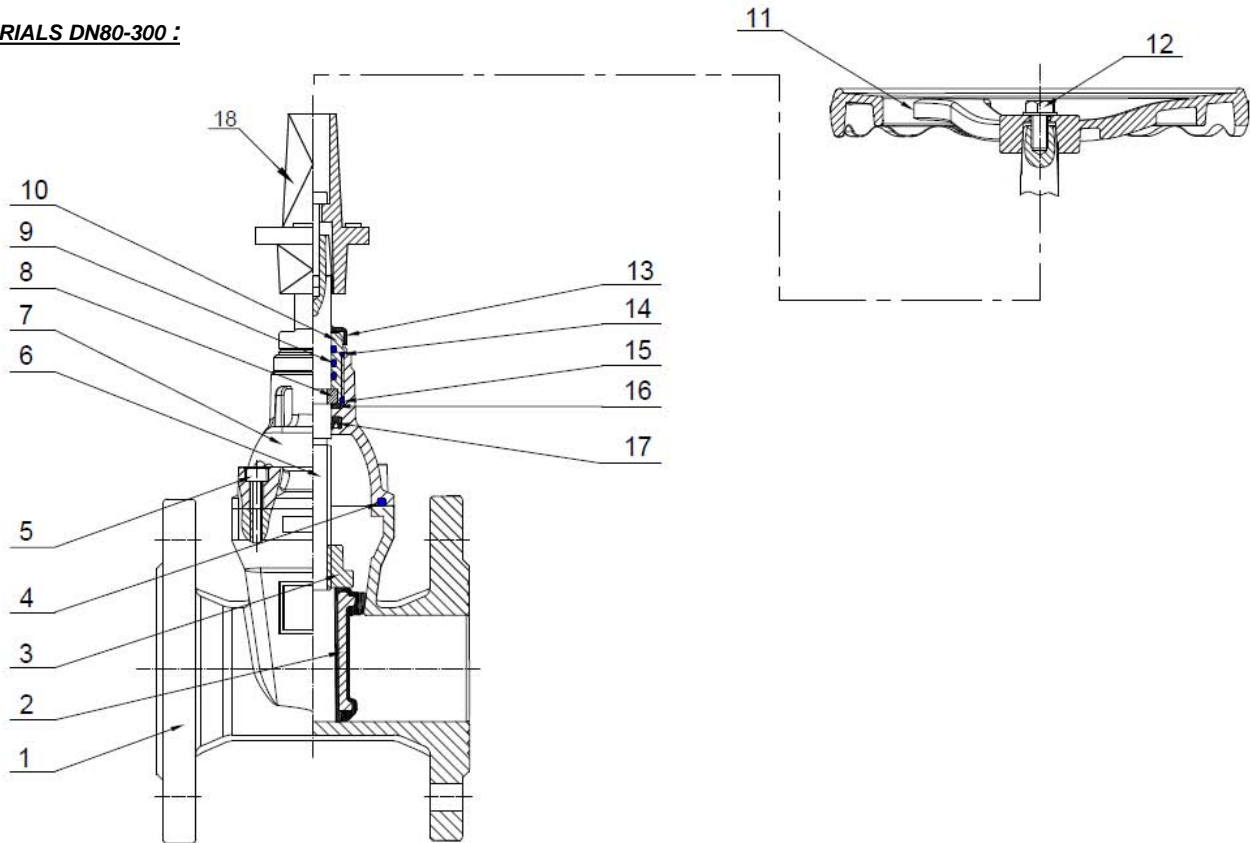
RESILIENT SEAT GATE VALVE PN10-16 F5
O^oGATE
MATERIALS DN80-300 :

Item	Designation	Materials
1	Body	Ductile iron EN GJS-500-7
2	Wedge	Ductile iron EN GJS-500-7 EPDM coated
3	Stem nut	Brass CuZn39Pb2
4	Bonnet gasket	NBR
5	Bonnet screw	C35
6	Stem	SS 420
7	Bonnet	Ductile iron EN GJS-500-7
8	Holding ring	Brass CuZn39Pb2
9	Stem O ring	NBR
10	Nut	Brass CuZn39Pb2
11	Handwheel	Ductile iron EN GJS-500-7
12	Handwheel screw	SS 304
13	Dust-coat	NBR
14	Stem O ring	NBR
15	Stem O ring	NBR
16	Ring	Nylon 66
17	Auto sealing ring	NBR
18	Square drive nut	Ductile iron EN GJS-500-7

RESILIENT SEAT GATE VALVE PN10-16 F5

O^oGATE

MATERIALS DN350 – 600 :

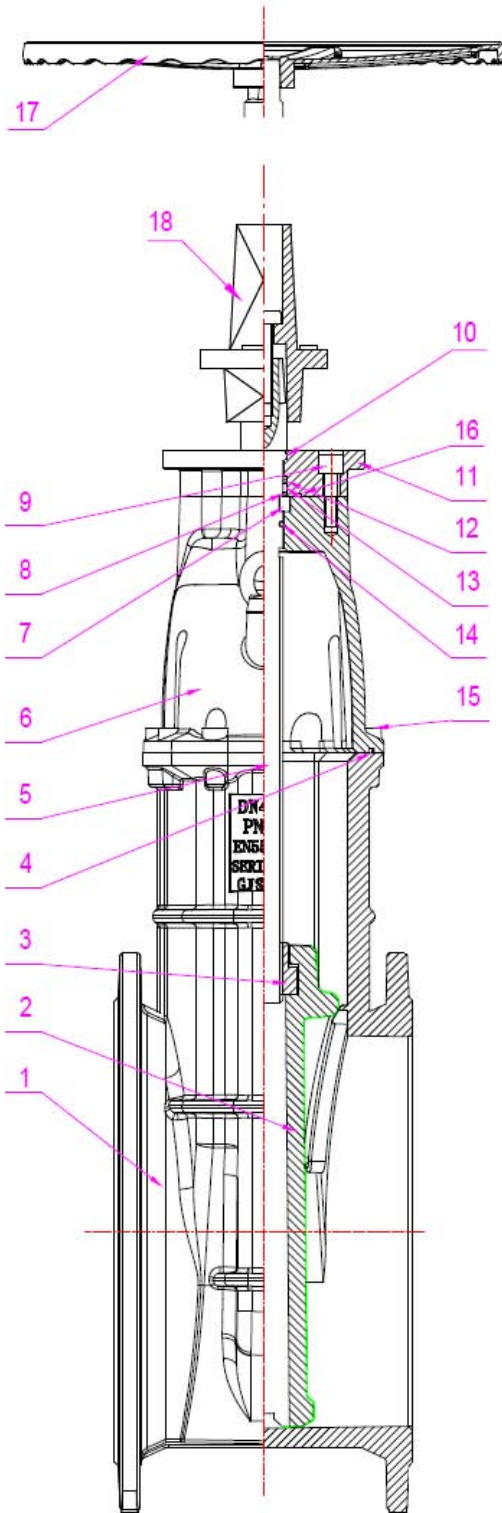

Item	Designation	Materials
1	Body	Ductile iron EN GJS-500-7
2	Wedge	Ductile iron EN GJS-500-7 + EPDM
3	Stem nut	Brass CuZn39Pb2
4	Bonnet gasket	NBR
5	Stem	SS 420
6	Bonnet	Ductile iron EN GJS-500-7
7	Holding ring	Brass CuZn39Pb2
8	O ring	NBR
9	Screw	RSt37-2
10	Dust-coat	NBR
11	Gland	Ductile iron EN GJS-500-7
12	O ring	NBR
13	Ring	Nylon 66
14	O ring	NBR
15	Bonnet bolt	Steel C35
16	O ring	NBR
17	Handwheel	Ductile iron EN GJS-500-7
18	Square drive nut	Ductile iron EN GJS-500-7

RESILIENT SEAT GATE VALVE PN10-16 F5 **O^oGATE**

SIZE DN40 - 65 (in mm) :

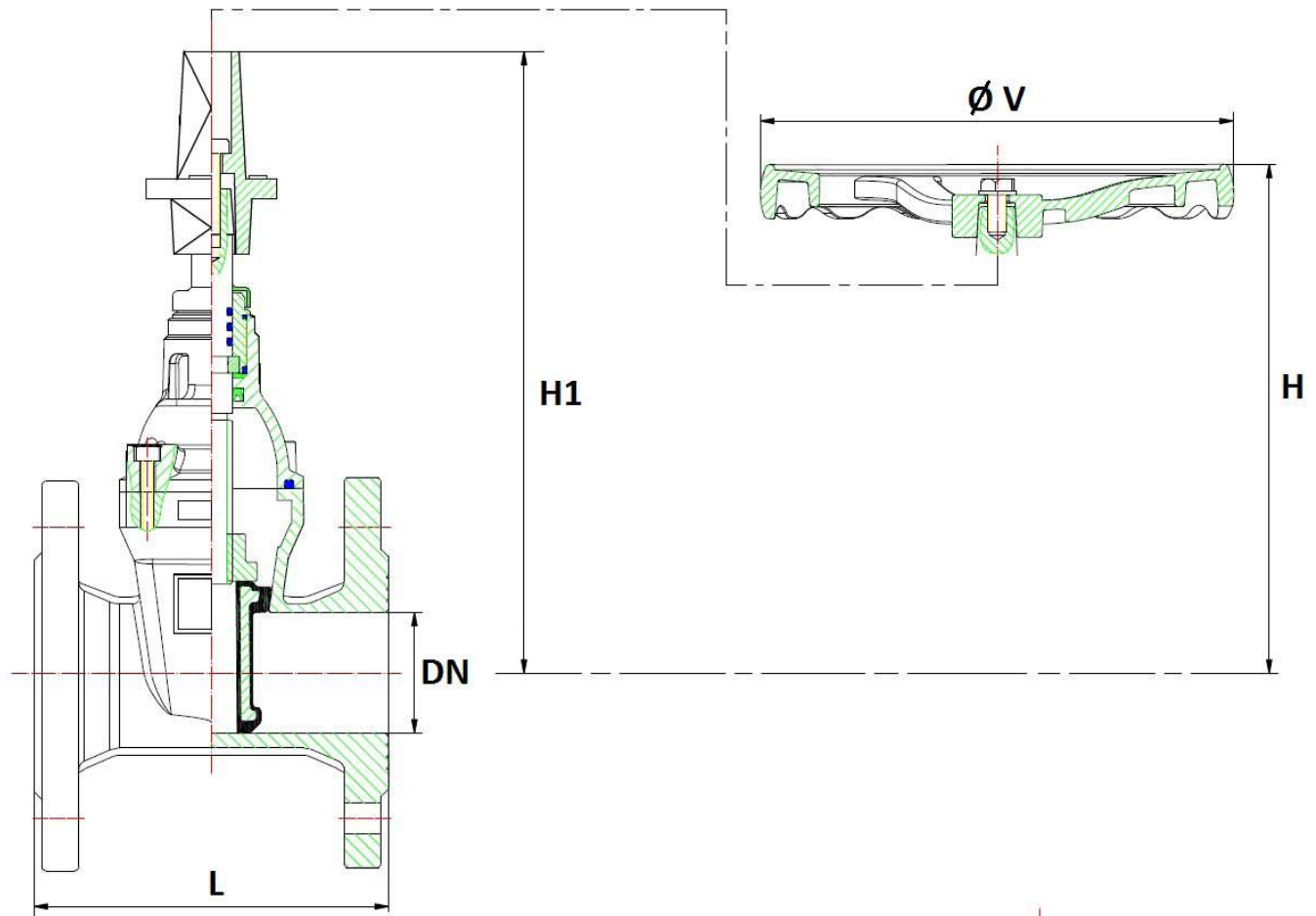

DN	40	50	65
L	240	250	270
H	190	215	235
H1	260	285	300
Ø V	200	200	200
Weight (in Kg)	7.80	9.48	13.10

RESILIENT SEAT GATE VALVE PN10-16 F5 **O^oGATE**

SIZE DN80-300 (in mm):

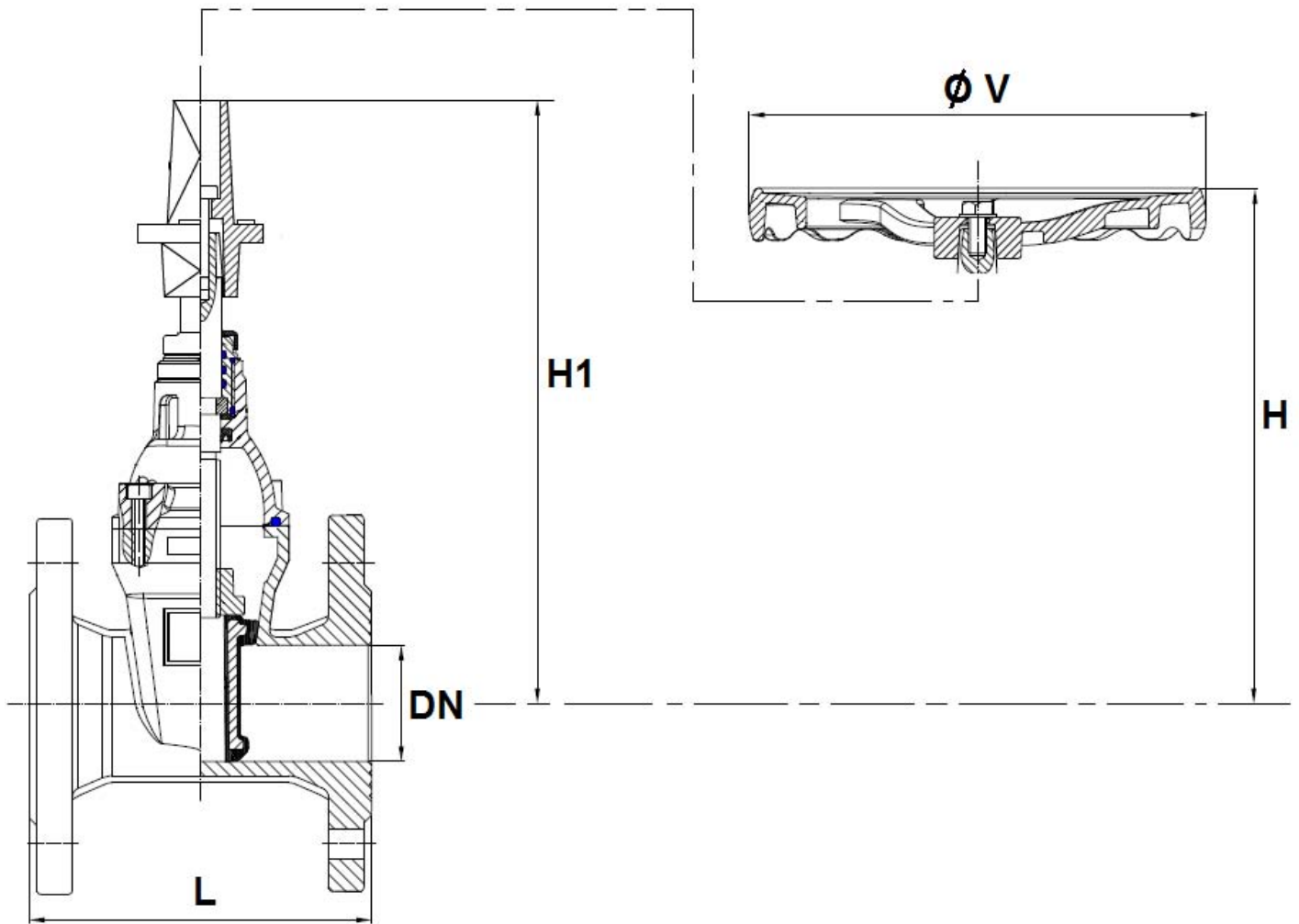

DN	80	100	125	150	200	250	300
L	280	300	325	350	400	450	500
H	265	315	350	385	485	600	680
H1	320	390	430	470	560	680	770
Ø V	254	254	315	315	315	406	406
Weight (Kg)	15.30	20.50	24.70	35.90	61.20	98.90	134.90

RESILIENT SEAT GATE VALVE PN10-16 F5 **O^oGATE**

SIZE DN350 - 600 (in mm) :

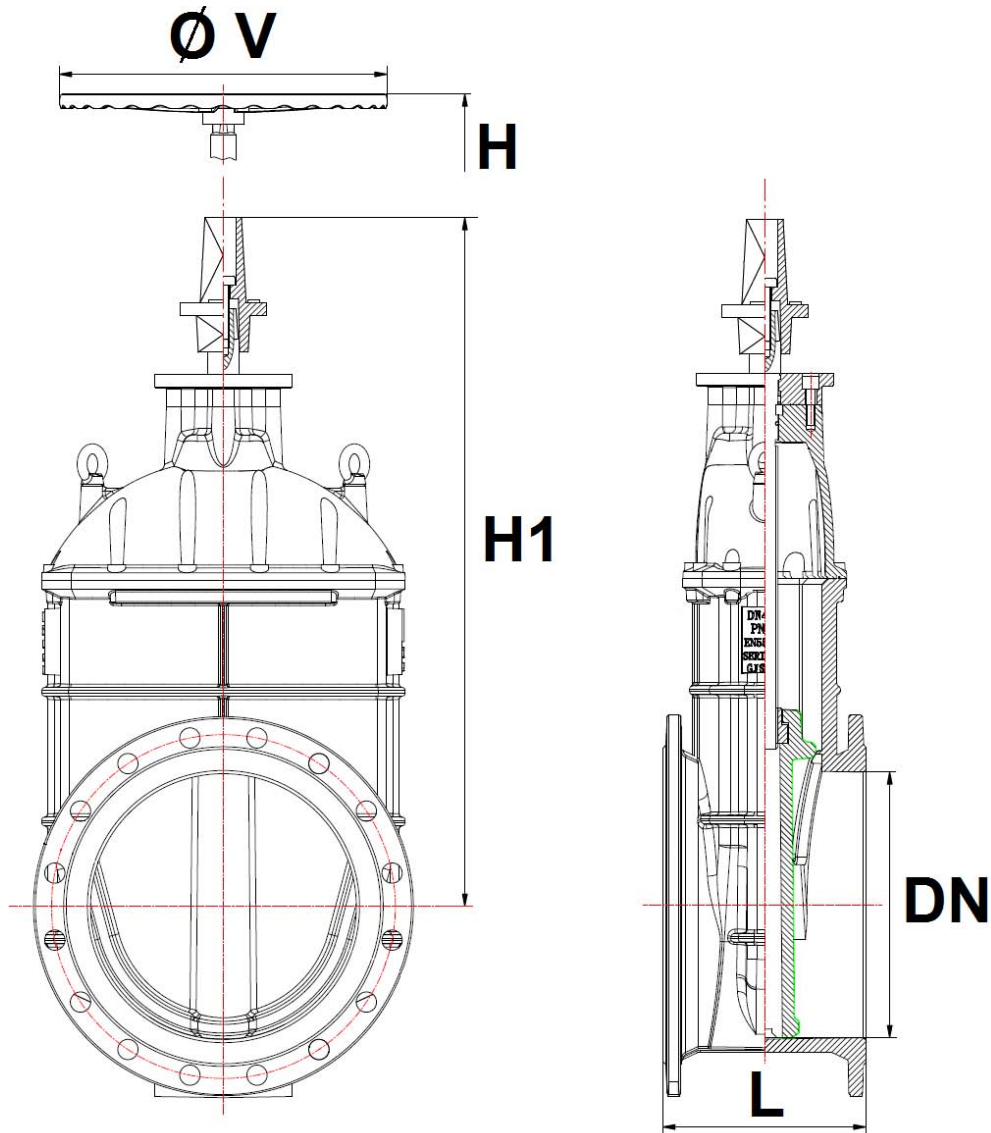

DN	350	400	450	500	600
L	550	600	650	700	800
H	810	890	1050	1230	1260
H1	900	1000	1150	1330	-
Ø V	500	500	500	650	650
Weight (in Kg)	225.90	248.50	410	517.30	810

RESILIENT SEAT GATE VALVE PN10-16 F5 **O^oGATE**

SQUARE DRIVE NUT SIZE (in mm) :

DN 40 – 300

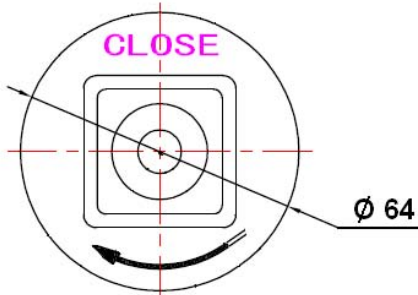
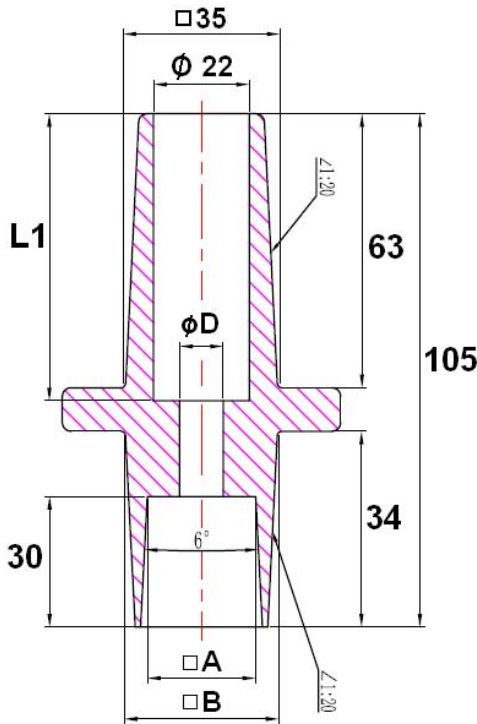

DN 350 - 400

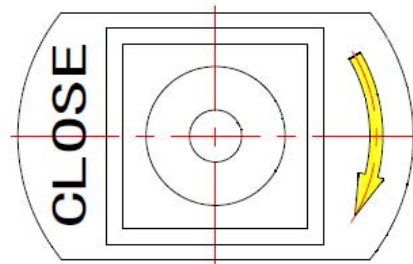
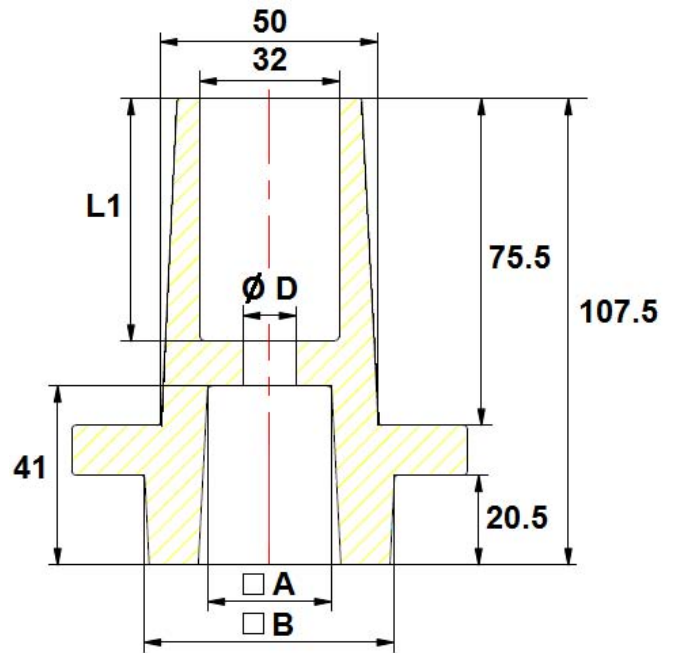

DN	40	50	65	80	100	125	150	200	250	300	350	400
A	14	14	14	17	17	19	19	19	24	24	28.5	28.5
B	34	34	34	34	34	36	36	36	42.5	42.5	57.5	57.5
L1	66	66	66	63	63	63	63	63	63	63	56	56
Ø D	10	10	10	10	10	10	10	10	12	12	12	12
Weight (Kg)	0.7	0.7	0.7	0.6	0.6	0.6	0.6	0.6	0.7	0.7	0.96	0.96
Ref.	9801831	9801831	9801831	9801832	9801832	9801833	9801833	9801833	9801834	9801834	9801838	9801838

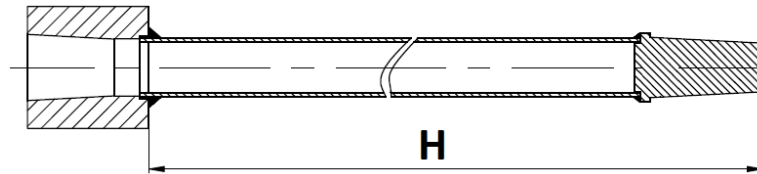
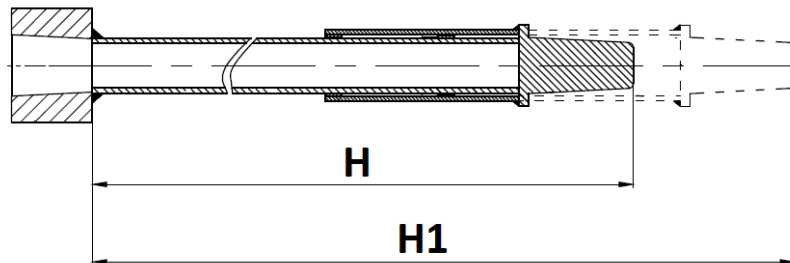
RESILIENT SEAT GATE VALVE PN10-16 F5
O^oGATE
STEM EXTENSION SIZE DN50-400 (in mm) :
FIXED TYPE

TELESCOPIC TYPE

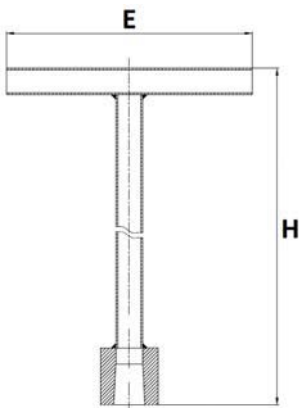
Ref.	DN	H	H1	Weight (Kg)
9802020	50-300	1000	-	3.7
9802031	50-300	1250	-	4.2
9802042	50-300	1500	-	4.5
9802060	50-200	1300	1800	9.6
9802070	50-200	2000	2500	11.8
9802029	350-400	1000	-	5.7
9802040	350-400	1250	-	6.5
9802051	350-400	1500	-	7.4

T HANDLE SIZE (in mm) :

Ref.	DN	E	H	Weight (Kg)
9802080	50-200	300	1316	3.5
9802081	250-300	450	1316	3.8
9802082	350-400	300	1316	7.92

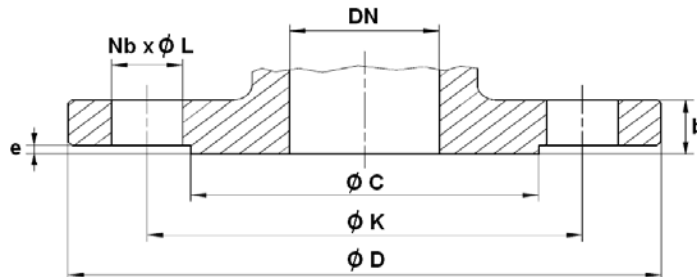
RESILIENT SEAT GATE VALVE PN10-16 F5

SIZE PN10 FLANGES (in mm) :

DN	40	50	65	80	100	125	150	200	250	300	350	400	450	500	600
Ø C	84	99	118	132	156	184	211	266	319	370	429	480	530	582	682
Ø D	150	165	185	200	220	250	285	340	405	460	520	580	640	715	840
Ø K	110	125	145	160	180	210	240	295	350	400	460	515	565	620	725
Nb x Ø L	4 x 19	4 x 19	4 x 19	8 x 19	8 x 19	8 x 19	8 x 23	8 x 23	12 x 23	12 x 23	16 x 23	16 x 28	20 x 28	20 x 28	20 x 31
b	19	19	19	19	19	19	19	20	22	24.5	26.5	28	30	31.5	36
e	3	3	3	3	3	3	3	3	3	4	4	4	4	4	5
Ref. 184	184040	184050	184065	184080	184100	184125	184150	184200	184250	184300	184350	184400	184450	184500	184600

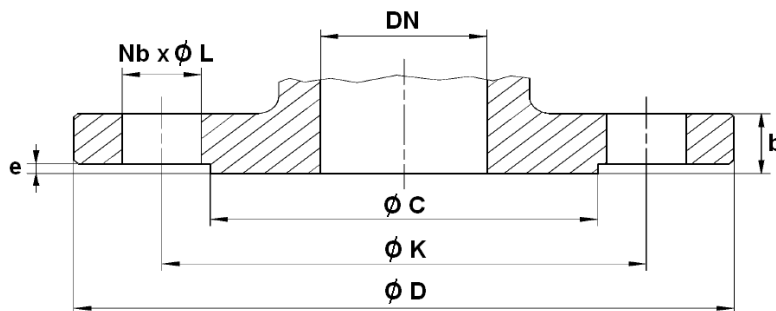
SIZE PN16 FLANGES (in mm) :

DN	200	250	300	350	400
Ø C	266	319	370	429	480
Ø D	340	405	460	520	580
Ø K	295	355	410	470	525
Nb x Ø L	12 x 23	12 x 28	12 x 28	16 x 28	16 x 31
b	20	22	24.5	26.5	28
e	3	3	4	4	4
Ref. 184	184201	184251	184301	184351	184401

RESILIENT SEAT GATE VALVE PN10-16 F5

O^oGATE

STANDARDS :

Fabrication according to ISO 9001 :2008

Designing according to DIN EN 1171

Pressure tests according to EN 12266-1, Range A

DIRECTIVE 2014/68/EU : Products excluded, article 1, § 2b up to DN300
Risk category I Module A from DN350 to 600

Certificate 3.1 on request

Length according to EN 558 series 15 (DIN 3202 F5)

Flanges R.F. according to EN 1092-2 PN10/16

English water agreement WRAS for the wedge EPDM coated from DN50 to 500

ADVICE : Our opinion and our advice are not guaranteed and SFERACO shall not be liable for the consequences of damages.
The customer must check the right choice of the products with the real service conditions.

RESILIENT SEAT GATE VALVE PN10-16 F5

O°GATE

INSTALLATION INSTRUCTIONS

GENERAL GUIDELINES :

Ensure that the valves to be used are appropriate for the conditions of the installation (type of fluid, pressure and temperature).

Be sure to have enough valves to be able to isolate the sections of piping as well as the appropriate equipment for maintenance and repair.

Ensure that the valves to be installed are of correct strength to be able to support the capacity of their usage.

Installation of all circuits should ensure that their function can be automatically tested on a regular basis (at least two times a year).

INSTALLATION INSTRUCTIONS :

Before installing the valves, clean and remove any objects from the pipes (in particular bits of sealing and metal) which could obstruct and block the valves.

Ensure that both connecting pipes either side of the valve (upstream and downstream) are aligned (if they're not, the valves may not work correctly).

Make sure that the two sections of the pipe (upstream and downstream) match, the valve unit will not absorb any gaps. Any distortions in the pipes may affect the tightness of the connection, the working of the valve and can even cause a rupture. To be sure, place the kit in position to ensure the assembling will work.

If sections of piping do not have their final support in place, they should be temporarily fixed. This is to avoid unnecessary strain on the valve.

Tighten the bolts in cross.

It's recommended to operate the valve (open and close) 1 to 2 times per year