

STAINLESS STEEL PRESSURE REDUCING VALVE PRV ELITE

MAIN CHARACTERISTICS

The stainless steel PRV elite valve is intended for the function of pressure reduction of the fluids such as water, air, liquids and compatible gases. Its construction is in stainless steel with tightness in FPM. The setting of the downstream pressure is made by means of the screw. The pressure gauge allows the direct reading of the reduced pressure. The flow is one-way indicated by an arrow on the body. The PRV valve suits with compatible fluids free of particles. It must be necessarily protected by a strainer installed upstream.

AVAILABLE MODELS

Stainless steel PRV : G 1/2" to 2" and NPT 1/2" to 1" (1 1/2" to 2" on request)

Stainless steel PRV flange : PN 16 DN 15 to DN 100 (Option : ANSI 150 and NPT)
BSP screwed end connections.

Downstream pressure range : 1-6 bar, 4-10 bar, 8-13 bar

LIMITS OF USE

Max allowed fluid pressure : PS	16 bar
ΔP mini :	1 bar
ΔP maxi :	13 bar
Max allowed fluid temperature : TS	-15°C / +100°C

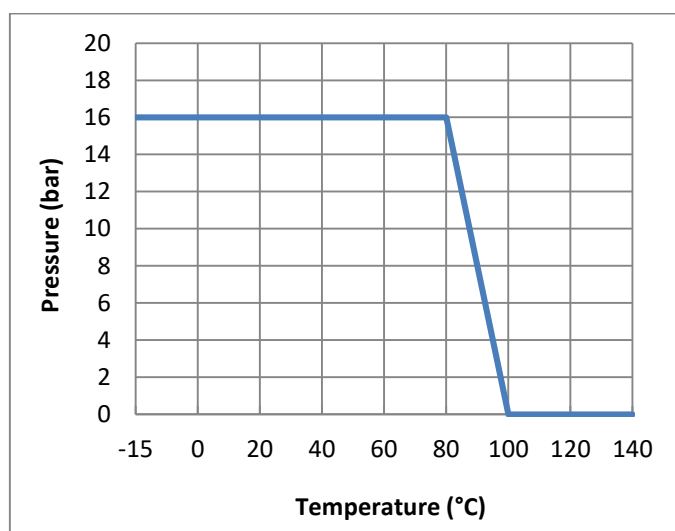

Modifications reserved

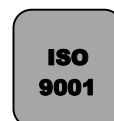

Flange type

STAINLESS STEEL PRESSURE REDUCING VALVE PRV ELITE

REGULATIONS AND STANDARDS OF CONSTRUCTIONS

Item	Standard	ON	Item	Standard
Pressure equipment directive 97/23	DN 15 to 25 : A3 § 3 excluded		Conception	ANSI B16.34
	DN 32 to 100 : catégorie II	0035	Test final	API 598
BSP theard	ISO 228		Flanges	EN 1092-1

CONSTRUCTION

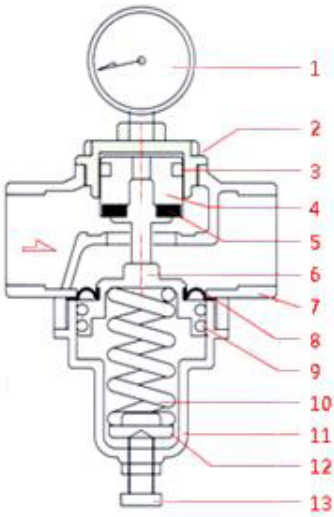
N°	Item	Material	Thread type
1	Gauge Ø 63	All stainless steel - 1/4 "	
2	Upper cover	Stainless steel 1.4408	
3	U-ring	FPM	
4	Shaft	Stainless steel 1.4408	
5	Sealing spacer	FPM	
6	Seat	Stainless steel 1.4408	
7	Body	Stainless steel 1.4408	
8	Diaphragm	FPM	
9	U-H-ring	FPM	
10	Spring	Spring steel	
11	Spring box	Stainless steel 1.4408	
12	Spring washer	Brass	
13	Adjusting screw	Stainless steel 1.4301	

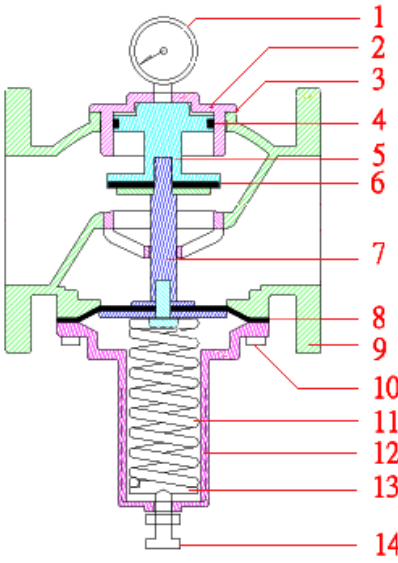
N°	Item	Material	Flange type
1	Gauge Ø 63	All stainless steel - 1/4 "	
2	Cover	Stainless steel 1.4408	
3	Sealing cover	FPM	
4	U-ring	FPM	
5	Upper seat	Stainless steel 1.4408	
6	Sealing spacer	FPM	
7	Lower seat	Stainless steel 1.4408	
8	Diaphragm	FPM	
9	Body	Stainless steel 1.4408	
10	Screw	Stainless steel 1.4301	
11	Spring	Spring steel	
12	Spring box	Stainless steel 1.4408	
13	Spring washer	Brass	
14	Adjusting screw	Stainless steel 1.4301	

Modifications reserved

STAINLESS STEEL PRESSURE REDUCING VALVE PRV ELITE

DIMENSIONS (mm)

DN	L	H1	H2*	D1	D2	Gauge connection	Weight (kg)	Thread type
15	70	120	80	30	60	1/4" RC	1,0	
20	85	125	105	35	60		1,2	
25	90	130	105	42	60		1,4	
40	115	140	130	60	73		2,6	
50	120	140	130	65	85		2,8	

* Completely unscrewed reticule adjusting screw

DN	L	H1	H2*	D1	D2	Gauge connection	Weight (kg)	Flange type
15	155	120	80	30	60	1/4" RC	2,6	
20	155	125	105	35	60		3	
25	155	130	105	42	60		3,7	
40	190	140	130	60	73		6,5	
50	195	140	130	65	85		7,8	
65	210	145	195	95	145		14,5	
80	225	145	195	95	145		15,4	
100	250	160	235	115	160		20,7	

* Completely unscrewed reticule adjusting screw

Modifications reserved

STAINLESS STEEL PRESSURE REDUCING VALVE PRV ELITE

DN	D	K	L	Qty	∅	Flanges EN 1092-1 PN16 Dimensions
15	95	65	14	4	M12	
20	105	75	14	4	M12	
25	115	85	14	4	M12	
40	150	110	19	4	M16	
50	165	125	19	4	M16	
65	185	145	19	4	M16	
80	200	160	19	8	M16	
100	220	180	19	8	M16	

DN	D	K	L	Qty	∅	Flanges ANSI 150 Dimensions
15	88,9	60,5	15,8	4	M14	
20	98,6	69,9	15,8	4	M14	
25	108	79,4	15,8	4	M14	
40	127	98,4	15,8	4	M14	
50	152	120,4	19	4	M16	
65	178	139,7	19	4	M16	
80	190	152,4	19	4	M16	
100	229	190,5	19	8	M16	

Modifications reserved

STAINLESS STEEL PRESSURE REDUCING VALVE PRV ELITE

SIZING

Selection of the size : You should not necessarily choose an overflow valve with a size equal to pipe's size. To set the PRV size, you must calculate it by using abacuses and formulae of calculation presented below.

Flow coefficients Kv (m³/h) of PRV :

DN	15	20	25	40	50	65	80	100
Kv	1,4	5,3	6,6	12,5	15	45	48	71

Formula of calculation for a liquid:

$$Kv = Q \times \sqrt{\frac{\rho}{\Delta P}}$$

Kv : flow coefficient in m³/h.

Q : flow in m³/h

ΔP : Difference of pressure upstream-downstream in bar

ρ : Volumic weight kg/dm³

Formula of calculation for a gas :

$$\text{Si } P_2 > P_1/2 \quad Kv = \frac{Q}{445} \times \sqrt{\frac{d \times T}{\Delta P \times P_2}}$$

$$\text{Si } P_2 < P_1/2 \quad Kv = \frac{Q}{240 \times P_1} \times \sqrt{d \times T}$$

<i>Kv</i>	<i>Flow coefficient</i>	<i>m³/h</i>
<i>Q</i>	<i>Flowrate in</i>	<i>Nm³/h</i>
<i>d</i>	<i>Volumic weight</i>	<i>Kg / m³</i>
<i>T</i>	<i>Absolute temperature</i>	<i>°K (°C +273)</i>
<i>P1</i>	<i>Upstream pressure (abs)</i>	<i>bar</i>
<i>P2</i>	<i>Downstream pressure (abs)</i>	<i>bar</i>
<i>ΔP</i>	<i>Pressure Différencial</i>	<i>bar</i>

Minimal gap from pressure : The reducer of pressure PRV has got its own pressure loss, that gives a minimal gap between upstream and downstream pressures. This gap value is from 15 to 20 % of the upstream pressure.

Double pressure reduction : A pressure reduction of a very high pressure to a very low pressure is possible in theory. The PRV authorizes a maximum ΔP of 13 bar. However a noisy functioning is to be expected. It is advised to plan a pressure reduction in 2 steps by using two pressure reducers. The calculation of the intermediate pressure is made as follows:

$$P \text{ intermédiaire} = \sqrt{P \text{ upstream} \times P \text{ downstream}}$$

Variation of upstream flowrate : When the upstream flowrate fluctuates in a too wide range, it is possible that the pressure downstream regarding to the setted pressure either that this it takes some time to recover the setted pressure.

Variation also fluctuate of the upstream pressure : When the upstream pressure fluctuates, the pressure downstream also fluctuates in the same way. If at the same time, the flowrate also comes to change, the stability of the downstream pressure becomes more difficult. If such variation is not acceptable for the intended use, it is necessary to prefer the choice of a control valve linked to in a transmitter of pressure settled downstream.

Phenomenon of pumping : When the pressure reducer is too big for the flow rate to be assured, an unstable operation of the device is to be expected (phenomenon says of "pumping"). Thus it is essential to size the pressure reducing valve neither too big, nor too small.

Modifications reserved



www.armat.cz

ARMAT spol. s r. o., Řetová 82, 561 41 Řetová
armat@armat.cz, Tel.: +420 465 585 258 / 030 / 031, Fax +420465 585 254

STAINLESS STEEL PRESSURE REDUCING VALVE PRV ELITE

TABLE OF FLOWRATE FOR WATER

Flowrate (m ³ /h) for water 20°C													
ΔP (bar)	1	2	3	4	5	6	7	8	9	10	11	12	13
DN 15	1,4	2,0	2,4	2,8	3,1	3,4	3,7	4,0	4,2	4,4	4,6	4,8	5,0
DN 20	5,3	7,5	9,2	10,6	11,9	13,0	14,0	15,0	15,9	16,8	17,6	18,4	19,1
DN 25	6,6	9,3	11,4	13,2	14,8	16,2	17,5	18,7	19,8	20,9	21,9	22,9	23,8
DN 40	12,5	17,7	21,7	25,0	28,0	30,6	33,1	35,4	37,5	39,5	41,5	43,3	45,1
DN 50	15,0	21,2	26,0	30,0	33,5	36,7	39,7	42,4	45,0	47,4	49,7	52,0	54,1
DN 65	45,0	63,6	77,9	90,0	101	110	119	127	135	142	149	156	162
DN 80	48,0	67,9	83,1	96,0	107	118	127	136	144	152	159	166	173
DN 100	71,0	100	123	142	159	174	188	201	213	225	235	246	256

Modifications reserved



www.armat.cz

ARMAT spol. s r. o., Řetová 82, 561 41 Řetová
armat@armat.cz, Tel.: +420 465 585 258 / 030 / 031, Fax +420465 585 254

STAINLESS STEEL PRESSURE REDUCING VALVE PRV ELITE

TABLE OF FLOWRATE FOR COMPRESSED AIR

		Flowrate (Nm ³ /h) for compressed air 0°C											
P Upstream (bar)		2	3	4	5	6	7	8	9	10	11	12	
Pressure downstream (bar)	1	DN 15	67	100	133	166	200	233	266	299	332	366	399
		DN 20	249	374	499	624	748	873	998	1 122	1 247	1 372	1 497
		DN 25	305	457	610	762	914	1 067	1 219	1 371	1 524	1 676	1 828
		DN 40	582	873	1 164	1 455	1 746	2 037	2 328	2 619	2 910	3 200	3 491
		DN 50	693	1 039	1 386	1 732	2 078	2 328	2 771	3 117	3 463	3 810	4 156
		DN 65	2 079	3 117	4 157	5 196	6 235	7 274	8 313	9 352	10 391	11 430	12 470
		DN 80	2 217	3 325	4 434	5 542	6 650	7 759	8 867	9 976	11 084	12 192	13 300
	DN 100	3 325	4 988	6 650	8 313	9 975	11 638	13 300	14 963	16 625	18 288	19 950	
	2	DN 15		100	133	166	200	233	266	299	332	366	399
		DN 20		374	499	624	748	873	998	1 122	1 247	1 372	1 497
		DN 25		457	610	762	914	1 067	1 219	1 371	1 524	1 676	1 828
		DN 40		873	1 164	1 455	1 746	2 037	2 328	2 619	2 910	3 200	3 491
		DN 50		1 039	1 386	1 732	2 078	2 328	2 771	3 117	3 463	3 810	4 156
		DN 65		3 117	4 157	5 196	6 235	7 274	8 313	9 352	10 391	11 430	12 470
		DN 80		3 325	4 434	5 542	6 650	7 759	8 867	9 976	11 084	12 192	13 300
	DN 100		4 988	6 650	8 313	9 975	11 638	13 300	14 963	16 625	18 288	19 950	
	3	DN 15			133	166	200	233	266	299	332	366	399
		DN 20			499	624	748	873	998	1 122	1 247	1 372	1 497
		DN 25			610	762	914	1 067	1 219	1 371	1 524	1 676	1 828
		DN 40			1 164	1 455	1 746	2 037	2 328	2 619	2 910	3 200	3 491
		DN 50			1 386	1 732	2 078	2 328	2 771	3 117	3 463	3 810	4 156
		DN 65			4 157	5 196	6 235	7 274	8 313	9 352	10 391	11 430	12 470
		DN 80			4 434	5 542	6 650	7 759	8 867	9 976	11 084	12 192	13 300
	DN 100			6 650	8 313	9 975	11 638	13 300	14 963	16 625	18 288	19 950	
	4	DN 15				166	200	233	266	299	332	366	399
		DN 20				624	748	873	998	1 122	1 247	1 372	1 497
		DN 25				762	914	1 067	1 219	1 371	1 524	1 676	1 828
		DN 40				1 455	1 746	2 037	2 328	2 619	2 910	3 200	3 491
		DN 50				1 732	2 078	2 328	2 771	3 117	3 463	3 810	4 156
		DN 65				5 196	6 235	7 274	8 313	9 352	10 391	11 430	12 470
		DN 80				5 542	6 650	7 759	8 867	9 976	11 084	12 192	13 300
	DN 100				8 313	9 975	11 638	13 300	14 963	16 625	18 288	19 950	
	5	DN 15					200	233	266	299	332	366	399
		DN 20					748	873	998	1 122	1 247	1 372	1 497
		DN 25					914	1 067	1 219	1 371	1 524	1 676	1 828
		DN 40					1 746	2 037	2 328	2 619	2 910	3 200	3 491
		DN 50					2 078	2 328	2 771	3 117	3 463	3 810	4 156
		DN 65					6 235	7 274	8 313	9 352	10 391	11 430	12 470
		DN 80					6 650	7 759	8 867	9 976	11 084	12 192	13 300
	DN 100					9 975	11 638	13 300	14 963	16 625	18 288	19 950	
	6	DN 15						233	266	299	332	366	399
		DN 20						873	998	1 122	1 247	1 372	1 497
		DN 25						1 067	1 219	1 371	1 524	1 676	1 828
		DN 40						2 037	2 328	2 619	2 910	3 200	3 491
		DN 50						2 328	2 771	3 117	3 463	3 810	4 156
		DN 65						7 274	8 313	9 352	10 391	11 430	12 470
		DN 80						7 759	8 867	9 976	11 084	12 192	13 300
	DN 100						11 638	13 300	14 963	16 625	18 288	19 950	

Modifications reserved



www.armat.cz

ARMAT spol. s r. o., Řetová 82, 561 41 Řetová
armat@armat.cz, Tel.: +420 465 585 258 / 030 / 031, Fax +420465 585 254

STAINLESS STEEL PRESSURE REDUCING VALVE PRV ELITE

INSTALLATION

Position of mounting : The usual position of mounting of the PRV is vertical on horizontal piping, manometer upward. mounting on vertical piping : Although not recommended this mounting is possible for diameters DN 15 for DN 50, only on downward flow. For the BPV DN 65 to DN 100, this position of mounting is forbidden.

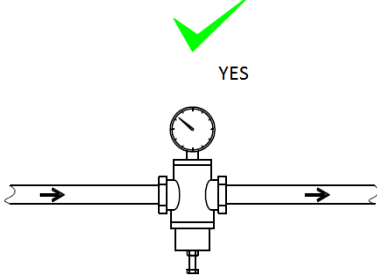
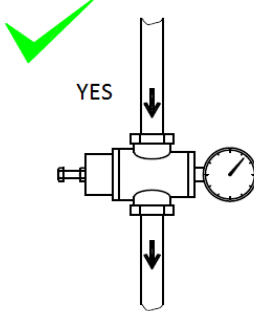
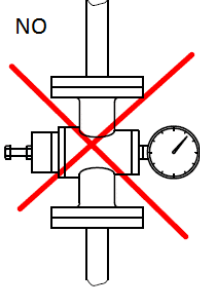
		
Horizontal mounting:	Vertical mounting :	
Any diameters	Authorized only on downward flow and DN15 to DN50	Forbidden on ascending flow or diameters superior to DN50

Convergent and divergent : If the diameter of the PRV is lower than the diameter of the piping (see § sizing), install upstream a convergent.

For a use on a gas, It is necessary to plan at the exit of the PRV a bigger sized pipe to that of the entrance and to link it by a divergent, The relaxed gas needing a bigger pipe's section.

Length of tranquillizing : To assure a good stability of the downstream pressure and reduce the turbulences at the exit of the PRV, plan before any of accident piping or device, A straight piping length at least equal to 5 x DN and 10 x DN if possible. In the case of a double pressure reduction, plan an identical length between both valves.

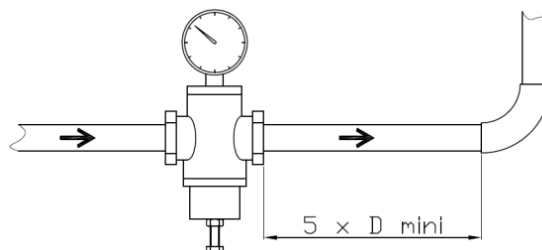

Upstream isolation : Plan a stop valve upstream to the PRV. This one is not necessarily tight in zero flowrate and cannot be considered as an isolation valve.

Upstream filtration : To protect the mechanism about 5/10 ° intern impurities, plan a filter of protection upstream to the PRV with a threshold of filtration.

Safety valve : For the pressure reduction of on a gas : the pressure reducer PRV not being necessarily tight in zero flowrate, the upstream pressures and downstream could balance each other. Plan a safety valve to protect downstream equipments to the PRV.

Modifications reserved

STAINLESS STEEL PRESSURE REDUCING VALVE PRV ELITE

Example of a pressure reducing system for a liquid :

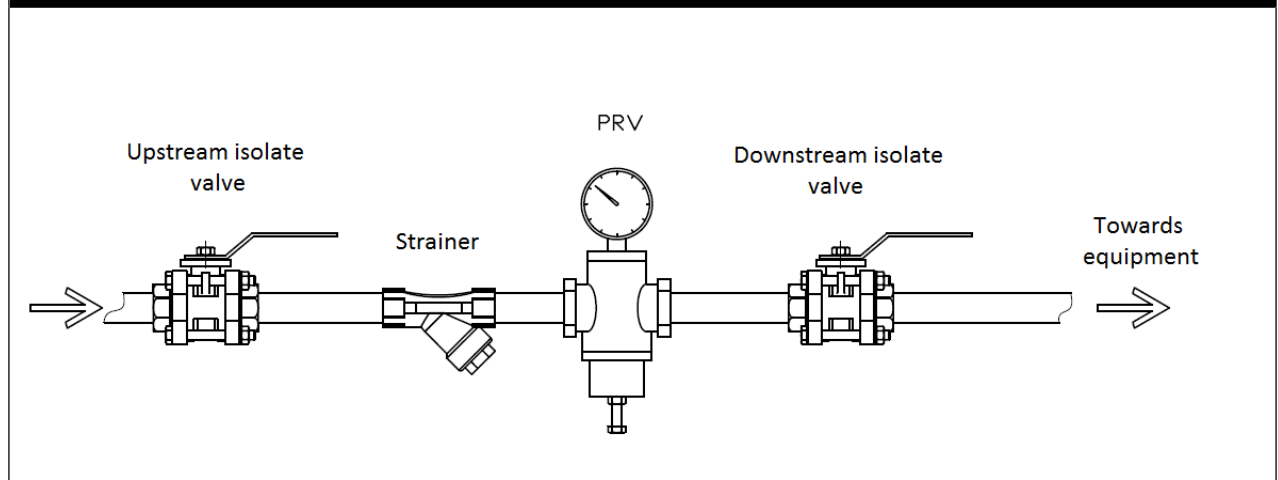

Example of a pressure reducing system for a gas :

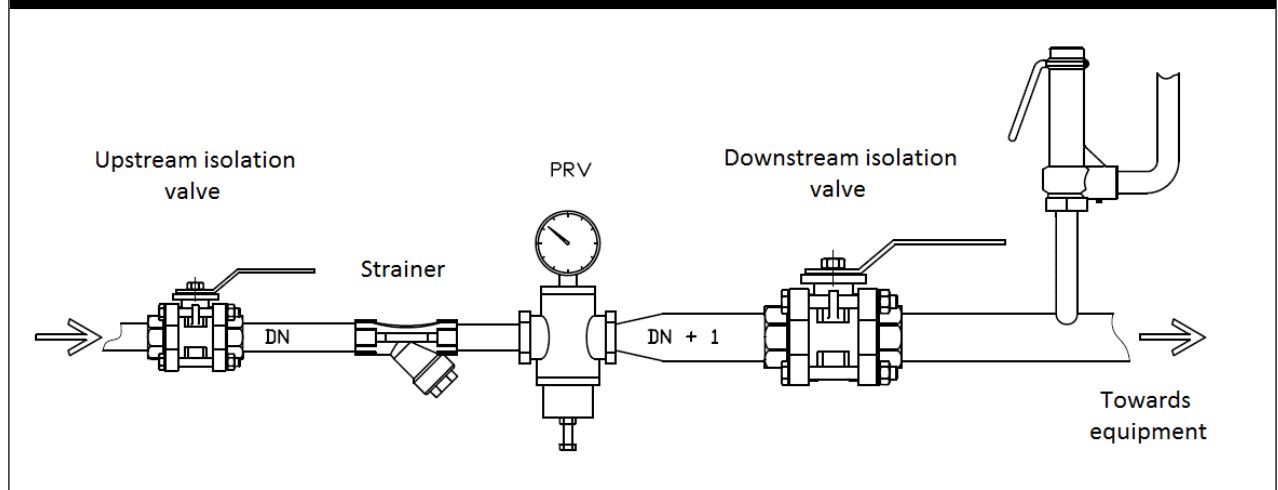

OPTIONS

Thread NPT according to ANSI B1.20

ANSI 150 flanges according to ANSI B16.5

Modifications reserved

STAINLESS STEEL PRESSURE REDUCING VALVE PRV ELITE

INSTRUCTIONS OF MOUNTING AND MAINTENANCE

1 - Mounting

Verify that the range of pressure indicated on the body is adequate with regard to the use. Before any installation, isolate the upstream pipe and the downstream, depressurize the pipe and bring the installation at room temperature. Install a valve of isolation in the upstream and an other one in the downstream. Install also a strainer upstream. Clean carefully the pipe of any particle by rinsing with water or a blowing with air. Install the reducer PRV by respecting the sense of the arrow indicated on the body and with the pressure gauge upward. Make the tightness of the grip of pressure gauge. Open slowly the upstream valve and the downstream. Use the adjusting screw item (13) or (14) and read the indication of the pressure on the manometer to adjust the pressure downstream looked for.

2 - Maintenance

Before any intervention, isolate the upstream pipings and the downstream by using valve intended for that purpose. Depressurize the pipe and bring the installation at room temperature. Unscrew completely the adjusting screw item (13) or (14). Remove screen the cork of the upstream strainer and clean or replace it. For a complete visit of the device, unscrew the parts (2) and (10). Verify the state of sealing parts (3), (4) and (6) or (3), (4), (6) and (8). Replace them if needed. Verify also the state of the spring item (10) or (11). Replace it if it is broken or strongly corroded. Clean all the internal parts. Reassemble all the internal parts, in the inverse order of the dismantling. Put back the device in service by opening slowly the upstream valve then the downstream valve. Adjust the upstream pressure by means of the screw item (14).

SPARE PARTS

DN	Kit of sealing FPM	Spring 1-6 bar	Spring 4-10 bar	Spring 8-13 bar
Thread type item	3, 5, 8, 9	10		
Flange type item	3, 4, 6, 8	11		
15	981784	981730	981731	981732
20	981785	981733	981734	981735
25	981786	981736	981737	981738
40	981787	981739	981740	981741
50	981788	981742	981743	981744
65	981789	981745	981746	981747
80	981790	981748	981749	981750
100	981791	981751	981752	981753

Spare pressure gauge item 1		
1-6 bar	4-10 bar	8-13 bar
M1616005	M1616006	M1616007

Modifications reserved