

D13 PED

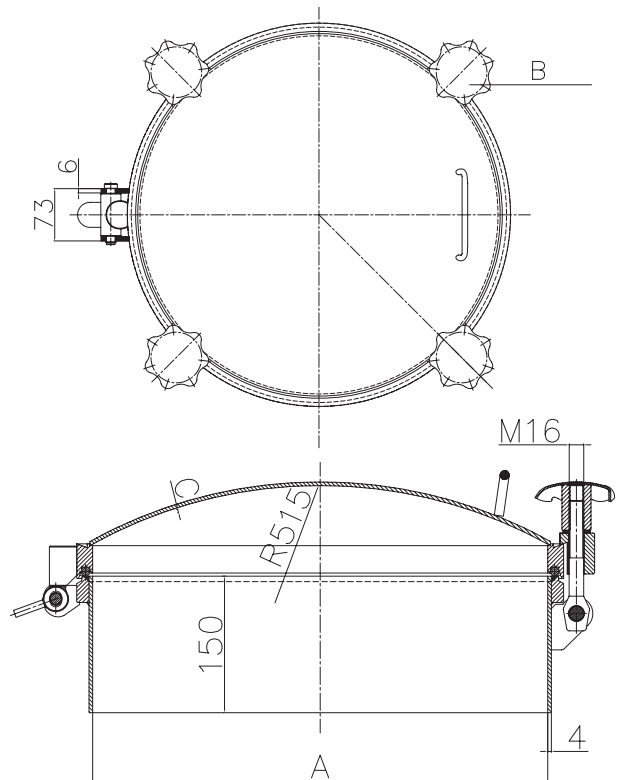

Upper lid on request: D13
Dimension: Ø 150 / 200 / 250 mm
Standard handwheel: VLT1609003S
Opening: outside
Material: AISI 304 nebo AISI 316
Standard gasket: silicone
Gasket on request: EPDM, PARA, Silicone, NBR, VITON
Surface: cover and frame satin
On request with sight glass (DN 50 – 65 – 80 – 100 – 125)
PED certificate on request



Order code	Mat.	Gasket
P2-D13-154-1.4301/P	304	PARA
P2-D13-154-1.4301/E	304	EPDM
P2-D13-154-1.4301/N	304	NBR
P2-D13-154-1.4301/S	304	Silicone
P2-D13-154-1.4301/V	304	VITON
P2-D13-154-1.4404/P	316L	PARA
P2-D13-154-1.4404/E	316L	EPDM
P2-D13-154-1.4404/N	316L	NBR
P2-D13-154-1.4404/S	316L	Silicone
P2-D13-154-1.4404/V	316L	VITON

Ø 150 mm, B = 4 ks

Order code						
and other variants by coding:						
P2	Manhole cover II.		Maximum temperature (-20/+200 °C)			
D13	Model		50	100	150	200
	A(Ø)	B (poč. ovl.)	Max. working pressure (bar)			
154	150	4	19	18	17	16
204	200	4	12	11	11	11
206	200	6	18	17	16	15
254	250	4	8	7	7	6,5
256	250	6	12	11	11	10
258	250	8	16	14	14	13
1.4301/1.4404	Material manhole cover					
P/E/N/S/V	Material gasket					