

Sight Glass type 85BF for aseptic clamp pipe connection DIN 11864-3

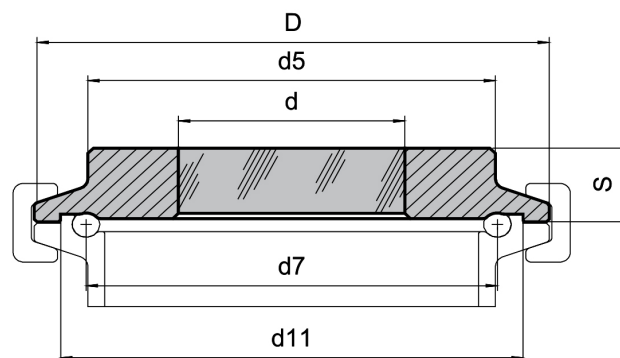
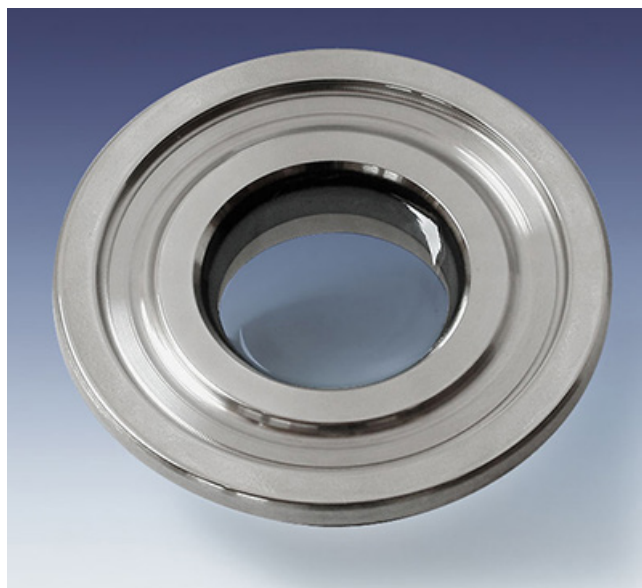

Applications:

- Sterile duty fitting to DIN 11864 part 3 form A
- Aseptic groove clamp for installation on aseptic round clamp form A

Advantages:

- Security against total failure
- Sight glass and sealing profile correspond to recommendations of EHEDG (European Hygienic Equipment Design Group) and to ASME BPE (Bioprocessing Equipment)
- Flush seal against atmospheric side
- Suitable for CIP and SIP cleaning
- Complies with GMP for clean condition, cleaning, sterilization
- We can supply with light fittings BKVLR A 24 V, AC/DC, 20 W or 50 W, mat. DIN 1.4301

Technical data:

Manufactured and tested to:

- Directive for pressure equipment 2014/68/EU, Module H (DIN/EN/ISO 9001)
- AD2000 Standards W0/TRD 100
- Sight glass fused to metal conforming to DIN 7079
- Materials to VdTÜV specifications and the DIN/EN designated standards

Material certificates:

- Certificate of Conformity EN 10204 – 3.1 or 3.2

Material:

- Glass: borosilicate to DIN 7080 / DIN 7079

Ring materials	Operating temperature
1.4462	-30 °C to +280 °C
2.4602	-60 °C to +300 °C
2.4610	-60 °C to +300 °C

Nominal size DN			max. operating pressure	D	d	d11	d7	d5	S	O-Ring
Series A DIN 11850	Series B ISO 1127	Series C ISO 2037 BS 4825								
20	-	-	16	50,5	20	32,4	24,76	42	12	22 x 3,5
-	-	1"	16	50,5	22	34,4	26,76	42	12	24 x 3,5
-	26,9	-	16	50,5	22	36,1	28,46	42	12	26 x 3,5
25	-	-	16	50,5	24	38,4	30,76	42	12	28 x 3,5
32	-	-	16	50,5	24	47,7	38,56	42	12	34 x 5
-	-	1½"	16	64	30	50,5	41,36	54	12	37 x 5
40	-	-	16	64	30	53,7	44,56	54	12	40 x 5
-	42,4	-	16	64	30	54,1	44,96	54	12	40,5 x 5
-	48,3	-	16	64	30	60,0	50,86	54	12	46,5 x 5
-	-	2"	16	77,5	35	63,5	54,36	62	14	50 x 5
50	-	-	16	77,5	35	65,7	56,56	62	14	52 x 5
-	60,3	-	10	91	40	72,0	62,86	78	14	58,5 x 5
-	-	2½"	10	91	40	75,9	66,76	78	14	62 x 5
65	-	-	10	91	40	81,7	72,56	78	14	68 x 5
-	76,1	-	10	106	50	88,4	78,26	93	14	73,5 x 5
-	-	3"	10	106	50	89,6	79,46	93	16	75 x 5
80	-	-	10	106	50	97,7	87,56	93	14	83 x 5
-	88,9	-	10	119	55	101,0	90,86	104	18	86,5 x 5
-	-	4"	10	130	60	114,4	103,96	115	18	100 x 5
100	-	-	10	130	60	116,7	106,56	115	18	102 x 5
-	114,3	-	10	144,4	65	125,9	115,6	124	21	111 x 5