

STAINLESS STEEL OVERFLOW VALVE BPV ELITE

MAIN CHARACTERISTICS

The stainless steel BPV elite over flow valve is intended for the discharge of fluids overflow when an upstream limitation of pressure is looked for, for example downstream to a pump. Stainless steel construction FPM tightness. The setting of the upstream pressure is made by means of the screw. The pressure gauge allows the direct reading of the upstream pressure. The flow is one-way indicated by an arrow on the body. The BPV valve only suits with compatible fluids free of particles. It must be necessarily protected by a strainer installed upstream.

AVAILABLE MODELS

Stainless steel BPV : G 1/2" to G 2"

Stainless steel BPV flange : PN 16 DN 15 to DN 100

BSP screwed end connections.

Upstream pressure range : 1-5 bar, 4-10 bar, 8-13 bar

LIMITS OF USE

Max allowed fluid pressure : PS	16 bar
ΔP mini :	1 bar
ΔP maxi :	13 bar
Max allowed fluid temperature : TS	-15°C / +100°C

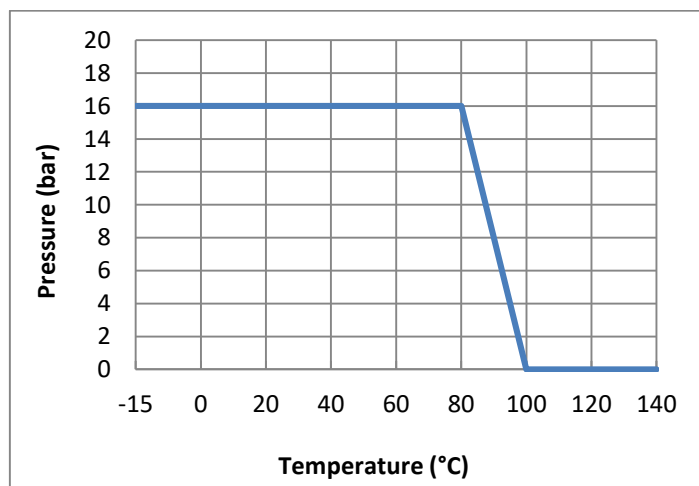

Flange type

Modifications reserved

STAINLESS STEEL OVERFLOW VALVE BPV ELITE

REGULATIONS AND STANDARDS OF CONSTRUCTION

Item	Standard	ON	Item	Standard
Pressure equipment Directive 97/23	DN 15 to 25 : A3 § 3 excluded		Conception	ANSI B16.34
	DN 32 to 100 : catégorie II	0035	Final test	API 598
BSP thread	ISO 228		Flanges	EN 1092-1

CONSTRUCTION

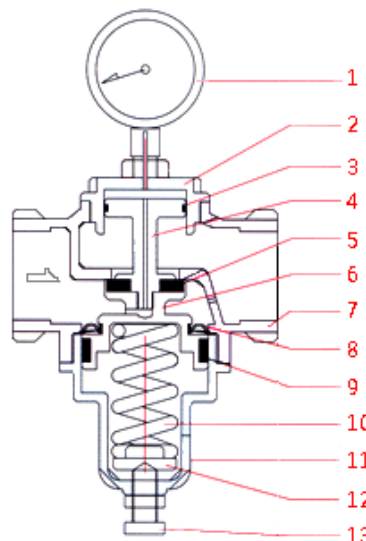
N°	Item	Material	Threadtype
1	Gauge Ø 63	All stainless steel - 1/4''	
2	Upper cover	Stainless steel 1.4408	
3	U-ring	FPM	
4	Shaft	Stainless steel 1.4408	
5	Sealing spacer	FPM	
6	Seat	Stainless steel 1.4408	
7	Body	Stainless steel 1.4408	
8	Diaphragm	FPM	
9	U-H-ring	FPM	
10	Spring	Spring steel	
11	Spring box	Stainless steel 1.4408	
12	Spring washer	Brass	
13	Adjusting screw	Stainless steel 1.4301	

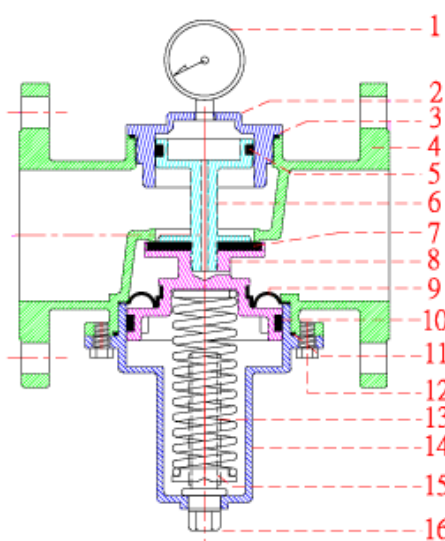
N°	Item	Material	Flangetype
1	Gauge Ø 63	All stainless steel - 1/4''	
2	Upper cover	Stainless steel 1.4408	
3	Sealing cover	FPM	
4	Body	Stainless steel 1.4408	
5	U-H-ring	FPM	
6	Upper seat	Stainless steel 1.4408	
7	Sealing spacer	FPM	
8	Lower seat	Stainless steel 1.4408	
9	Diaphragm	FPM	
10	U-H-ring	FPM	
11	Washer	FPM	
12	Screw	Stainless steel 1.4301	
13	Spring	Spring steel	
14	Spring box	Stainless steel 1.4301	
15	Spring washer	Brass	
16	Adjusting screw	Stainless steel 1.4301	

Modifications reserved

STAINLESS STEEL OVERFLOW VALVE BPV ELITE

DIMENSIONS (mm)

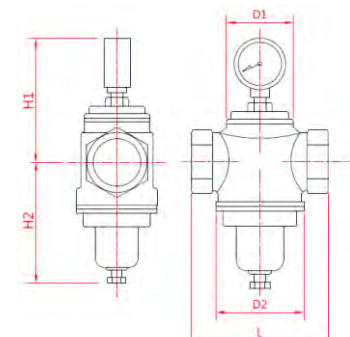
DN	L	H1	H2*	D1	D2	Gauge connection	Weight (kg)	Thread type
15	70	120	80	30	60	1/4" RC	1,0	
20	85	125	105	35	60		1,2	
25	90	130	105	42	60		1,4	
40	115	140	130	60	73		2,6	
50	120	140	130	65	85		2,8	

* Completely unscrewed reticule adjusting screw

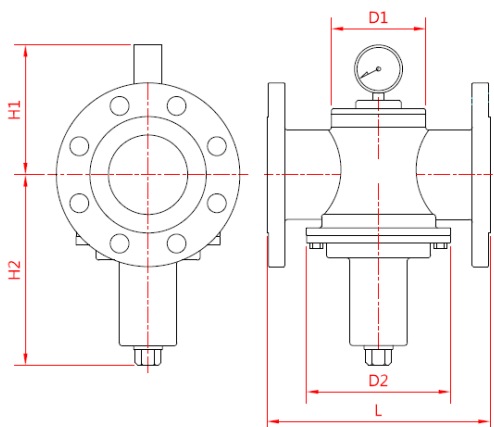
DN	L	H1	H2*	D1	D2	Gauge connection	Weight (kg)	Flange type
15	155	120	80	30	60	1/4" RC	2,6	
20	155	125	105	35	60		3	
25	155	130	105	42	60		3,7	
40	190	140	130	60	73		6,5	
50	195	140	130	65	85		7,8	
65	210	145	195	95	145		14,5	
80	225	145	195	95	145		15,4	
100	250	160	235	115	160		20,7	

* vis de réglage complètement dévissée

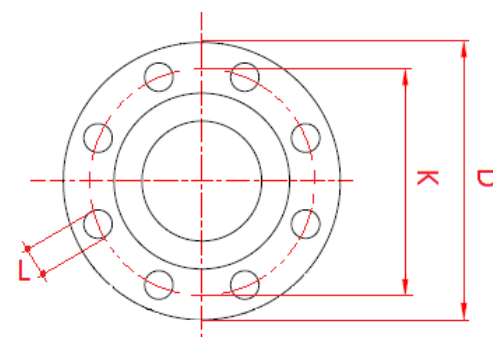
DN	D	K	L	Qty	ø	Flanges EN 1092-1 PN16 Dimensions
15	95	65	14	4	M12	
20	105	75	14	4	M12	
25	115	85	14	4	M12	
40	150	110	19	4	M16	
50	165	125	19	4	M16	
65	185	145	19	4	M16	
80	200	160	19	8	M16	
100	220	180	19	8	M16	

Modifications reserved

STAINLESS STEEL OVERFLOW VALVE BPV ELITE

SIZING

Selection of the size : You should not necessarily choose an overflow valve which a size equal to pipe's size. To set the BVP size, you must calculate it by using abacuses and formulae of calculation presented below.

Flow coefficients Kv (m³/h) of BPV :

DN	15	20	25	40	50	65	80	100
Kv	1,4	5,3	6,6	12,5	15	45	48	71

Formula of calculation for a liquid:

$$Kv = Q \times \sqrt{\frac{\rho}{\Delta P}}$$

Kv : flow coefficient in
m³/h.

Q : flow in
m³/h

ΔP : Difference of pressure
upstream-downstream in
bar

ρ : Volumic weight
kg/dm³

Formula of calculation for a gas :

$$\text{Si } P2 > P1/2 \quad Kv = \frac{Q}{445} \times \sqrt{\frac{d \times T}{\Delta P \times P2}}$$

Kv Flow coefficient m³/h

Q Flowrate in m³/h

d Volumic weight Kg / m³

T Absolute temperature °K (°C +273)

$$\text{Si } P2 < P1/2 \quad Kv = \frac{Q}{240 \times P1} \times \sqrt{d \times T}$$

P1 Upstream pressure bar

P2 Downstream pressure bar

FLOWRATE DIAGRAM FOR WATER

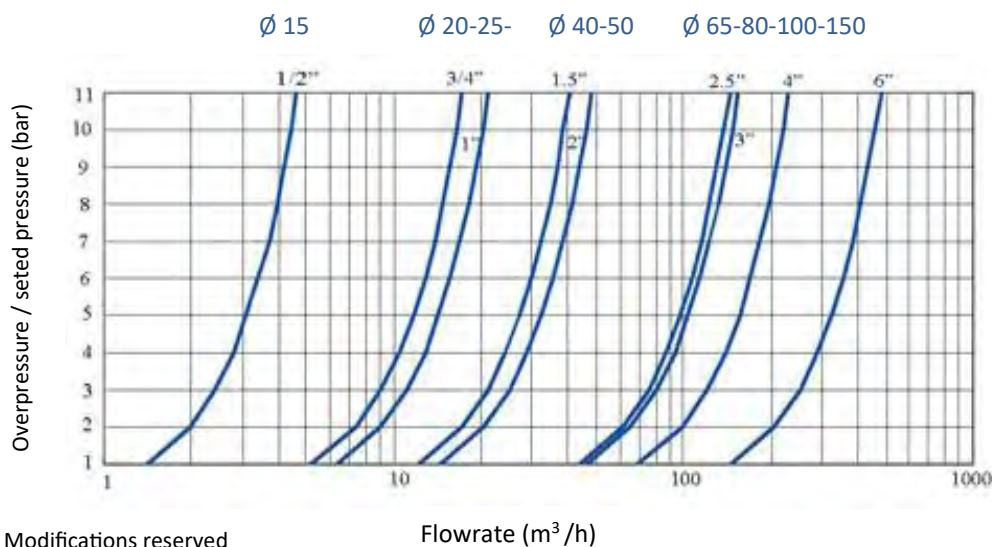

STAINLESS STEEL OVERFLOW VALVE BPV ELITE

INSTALLATION

Position of mounting: The usual position of mounting of the BPV is vertical on horizontal piping, manometer upward. Mounting on vertical piping : Although not recommended this mounting is possible for diameters DN 15 for DN 50, only on downward flow. For the BPV DN 65 to DN 100, this position of mounting is forbidden.

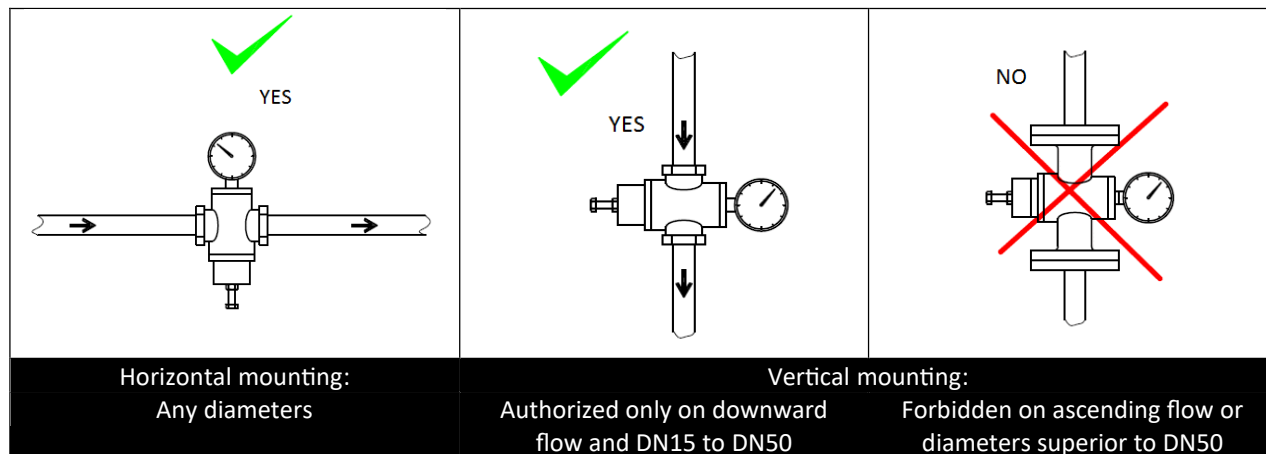

Convergent and divergent: If the diameter of the BPV is lower than the diameter of the piping (see § sizing), install upstream a convergent.

For a use on a gas, It is necessary to plan at the exit of the BPV a bigger sized pipe to that of the entrance and to link it by a divergent, The relaxed gas needing a bigger pipe's section.

Upstream pipe isolation: Plan a stop valve upstream to the overflow BPV. The BPV is necessarily tight when flow is equal to zero.

Upstream filtration: To protect the mechanism against impurities, plan a protection's strainer upstream to the BPV with a 5/10° screen.

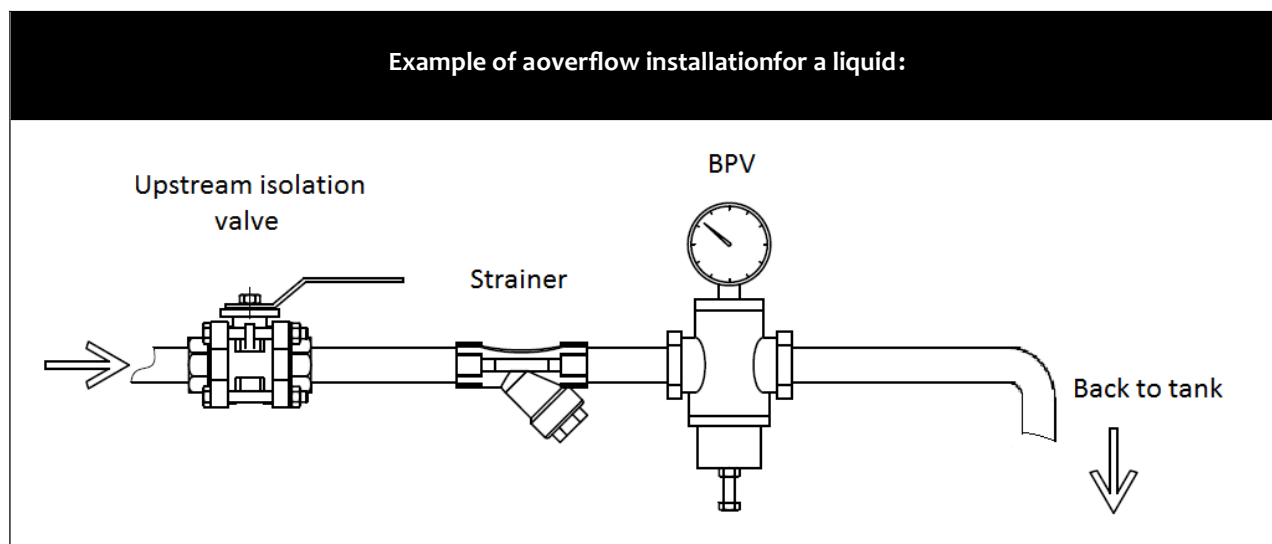

OPTIONS

Thread NPT according to ANSI B1.20

ANSI 150 flanges according to ANSI B16.5

Modifications reserved

STAINLESS STEEL OVERFLOW VALVE BPV ELITE

INSTRUCTIONS OF MOUNTING AND MAINTENANCE

1 - Mounting

Verify that the range of pressure indicated on the body is adequate with regard to the use. Before any installation, isolate the upstream pipe, depressurize the pipe and bring the installation at room temperature. Install a valve of isolation in the upstream. Install also a upstream strainer. Clean carefully the pipe of any particle by rinsing with water or a blowing with air. Install the overflow BPV by respecting the sense of the arrow indicated on the body and with the pressure gauge upward. Make the tightness of the grip of the pressure gauge. Open slowly the upstream valve. Use the adjusting screw item (13) or (16) and read the indication of the pressure on the manometer to adjust the upstream pressure looked for.

2 - Maintenance

Before any intervention, isolate the upstream piping by using the valve intended for that purpose. Depressurize the pipe and bring the installation at room temperature. Unscrew completely the adjusting screw item (13) or (16). Remove screen the cork of the upstream strainer and clean or replace it. For a complete visit of the device, unscrew the parts (2) and (12). Verify the state of sealing parts (3), (5), (8) and (9) or (3), (5), (7), (9) and (10). Replace them if needed. Verify also the state of the spring item (10) or (13). Replace it if it is broken or strongly corroded. Clean all the internal parts. Reassemble all the internal parts, in the inverse order of the dismantling. Put back the device in service by opening slowly the upstream valve. Adjust the upstream pressure by means of the screw item (13) or (16).

SPARE PARTS

DN	Kit of sealing FPM	Spring 1-5 bar	Spring 4-10 bar	Spring 8-13 bar
Thread type item	3, 5, 8, 9	10		
Flange type item	3, 5, 7, 9, 10	13		
15	981792	981760	981761	981762
20	981793	981763	981764	981765
25	981794	981766	981767	981768
40	981795	981769	981770	981771
50	981796	981772	981773	981774
65	981797	981810	981811	Please consult us
80	981798	981813	981814	Please consult us
100	981799	981816	981817	Please consult us

Spare pressure gauge item 1		
1-6 bar	4-10 bar	8-13 bar
M1616005	M1616006	M1616007

Modifications reserved