

STAINLESS STEEL NEEDLE VALVE PN 400 F/F



ISO 9001:2008
BUREAU VERITAS
Certification



- Size :** DN 1/4" to 1"
Ends : Female - Female BSP or NPT
Min Temperature : - 20°C
Max Temperature : + 180°C
Max Pressure : 400 Bars
Specifications : Rotating rising stem
1 piece type
Reduced bore
Materials : SS ASTM A351 CF8M

STAINLESS STEEL NEEDLE VALVE PN 400 F/F

SPECIFICATIONS :

Respect the flow direction (indicated by the arrow)
 Reduced bore
 Rising rotating stem
 1 piece type
 Stainless steel type
 6000 Psi type (PN400)

USE :

For common fluids of 2nd group
 Min and max Temperature Ts : - 20°C to + 180°C
 Max Pressure Ps : 400 bars (see graph)

PRESSURE / TEMPERATURE GRAPH (STEAM EXCLUDED) :

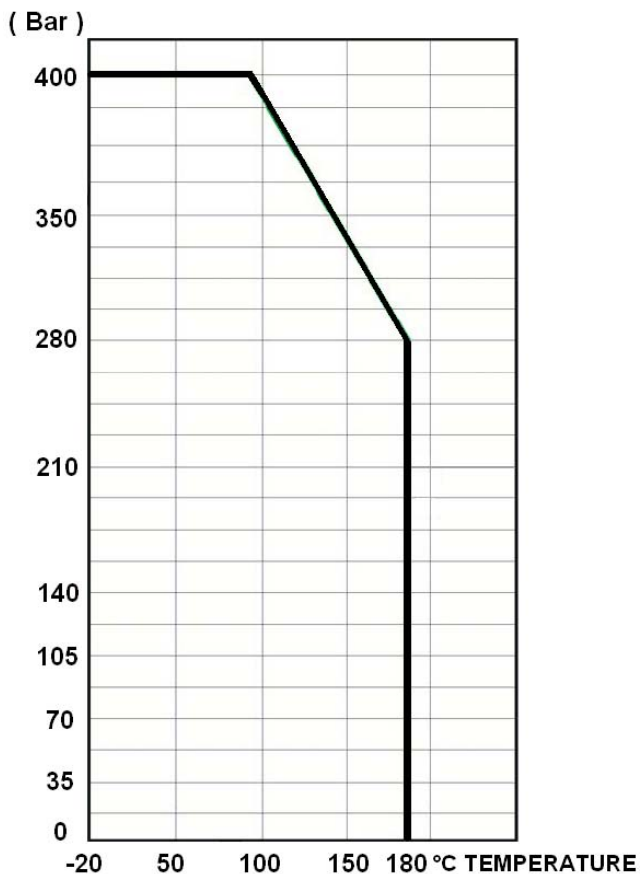

FLOW COEFFICIENT Kvs (m³ / h) :

| DN | 1/4" | 3/8" | 1/2" | 3/4" | 1" |
|----------------------------|------|------|------|------|------|
| Kvs (m ³ / h) | 0.7 | 0.78 | 1.04 | 1.12 | 1.55 |

STAINLESS STEEL NEEDLE VALVE PN 400 F/F

RANGE :

Stainless steel threaded female BSP cylindrical **Ref. 481** from DN 1/4" to DN 1"
Stainless steel threaded female NPT **Ref. 487** from DN 1/4" to DN 1"

MATERIALS :

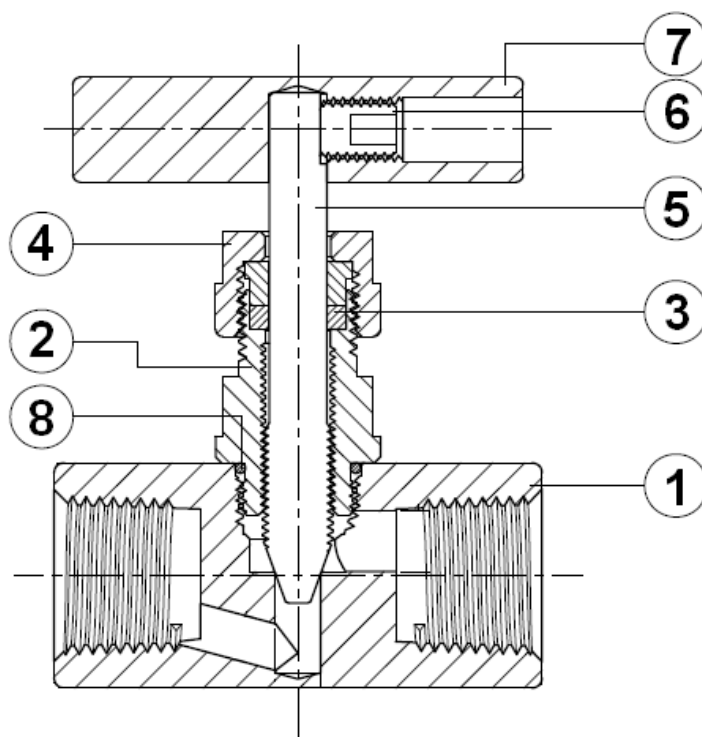

| Item | Designation | Materials |
|------|--------------|----------------|
| 1 | Body | ASTM A351 CF8M |
| 2 | Bonnet | ASTM A240-304 |
| 3 | Packing | PTFE |
| 4 | Packing nut | SS 304 |
| 5 | Stem | ASTM A240-304 |
| 6 | Handle screw | SS 304 |
| 7 | Handle | SS 304 |
| 8 | O ring | FKM |

STAINLESS STEEL NEEDLE VALVE PN 400 F/F

SIZE (in mm) :

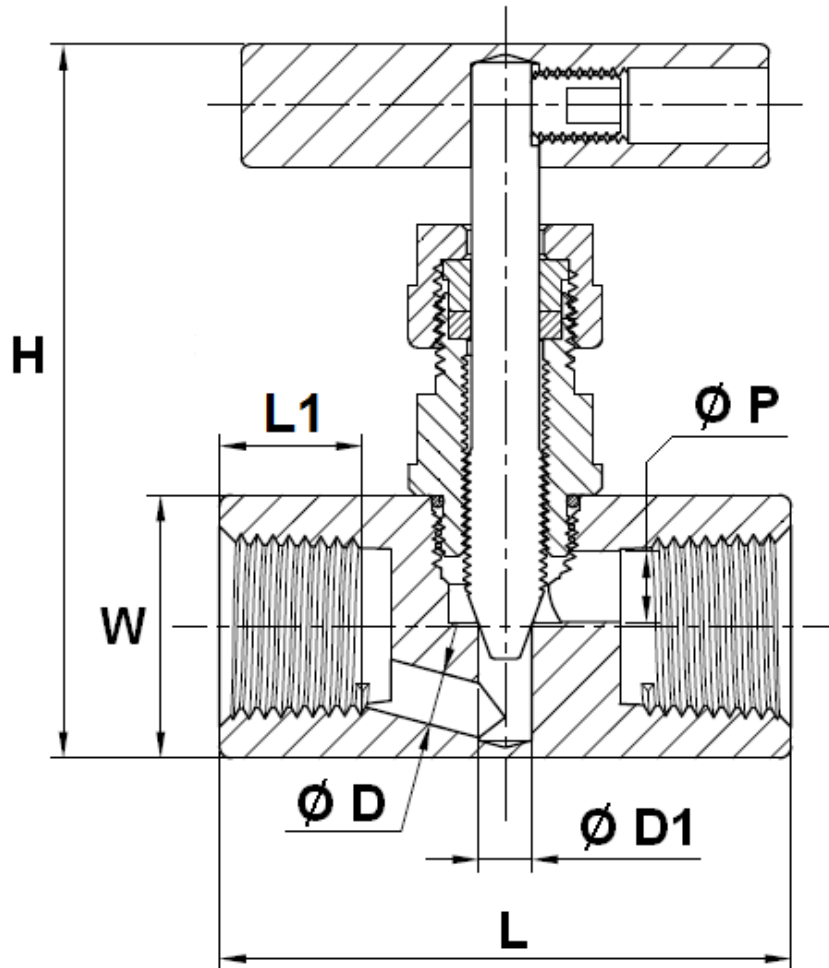

| Ref. | DN | 1/4" | 3/8" | 1/2" | 3/4" | 1" |
|---------|---------------|------|------|------|-------|-------|
| 481/487 | L | 45.5 | 59 | 65 | 70 | 80 |
| | L1 | 9.5 | 12 | 16.3 | 17 | 19 |
| | H (closed) | 76.5 | 78.2 | 79.7 | 115 | 116.2 |
| | H (opened) | 87.1 | 89.8 | 93.4 | 129.4 | 136.7 |
| | W on flat | 22 | 25 | 30 | 35 | 45 |
| | Ø D | 5 | 5 | 6 | 8 | 8 |
| | Ø D1 | 6 | 6 | 6 | 8 | 8 |
| | Ø P | 5 | 6.3 | 8 | 10 | 12 |
| | Weight (Kg) | 0.3 | 0.4 | 0.5 | 0.8 | 1.3 |

STAINLESS STEEL NEEDLE VALVE PN 400 F/F**NUMBER OF TURNS TO CLOSE OR OPEN THE VALVE :**

| DN | 1/4" | 3/8" | 1/2" | 3/4" | 1" |
|-------------|------|------|------|------|----|
| Nb of turns | 8 | 9 | 11 | 8 | 12 |

STANDARDS :

Fabrication according to ISO 9001 : 2008

Pressure tests according to API 598, table 6

Threaded female BSP cylindrical ends according to ISO 7/1 Rp

Threaded female NPT ends according to AMSE B1.20.1

DIRECTIVE 97/23/CE : Concerned by article 3, § 3

ATEX Group II Category 2 G/2D Zone 1 & 21 Zone 2 & 22 (optional marking)

ADVICE : Our opinion and our advice are not guaranteed and SFERACO shall not be liable for the consequences of damages.
The customer must check the right choice of the products with the real service conditions.

STAINLESS STEEL NEEDLE VALVE PN 400 F/F

INSTALLATION INSTRUCTIONS

GENERAL GUIDELINES :

Ensure that the valves to be used are appropriate for the conditions of the installation (type of fluid, pressure and temperature).

Be sure to have enough valves to be able to isolate the sections of piping as well as the appropriate equipment for maintenance and repair.

Ensure that the valves to be installed are of correct strength to be able to support the capacity of their usage.

Installation of all circuits should ensure that their function can be automatically tested on a regular basis (at least two times a year).

INSTALLATION INSTRUCTIONS :

Before installing the valves, clean and remove any objects from the pipes (in particular bits of sealing and metal) which could obstruct and block the valves.

Ensure that both connecting pipes either side of the valve (upstream and downstream) are aligned (if they're not, the valves may not work correctly).

Make sure that the two sections of the pipe (upstream and downstream) match, the valve unit will not absorb any gaps. Any distortions in the pipes may affect the tightness of the connection, the working of the valve and can even cause a rupture. To be sure, place the kit in position to ensure the assembling will work.

The theoretical lengths given by ISO/R7 for the tapping are typically longer than required, the length of the thread should be limited, and **check that the end of the tube does not press right up to the head of the thread.**

Never use a vice to tighten the fixings of the valve.

If sections of piping do not have their final support in place, they should be temporarily fixed. This is to avoid unnecessary strain on the valve.

It may be necessary to screw the packing gland during using according to the type of use.

Do not use a tool to shut the valve

Fluids in the valve must not contain solid objects (it could damaged the seat).

It's recommended to operate the valve (open and close) 1 to 2 times per year