

Lisovací tvarovky Inox Press

● trubky, kolena, T-kusy ...

● adaptéry, přechody, spojení ...

● ventily, těsnění ...

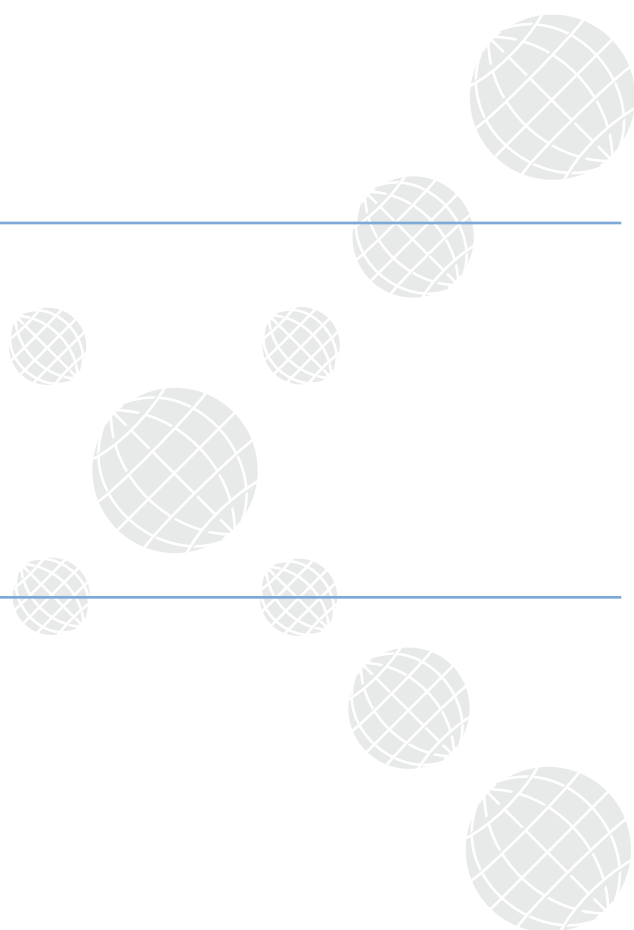

INOX PRESS

Výhody a možné použití:

- ☞ velmi rychlá a snadná instalace
- ☞ použití v průmyslových rozvodech teplé a studené vody
- ☞ pro průmyslové a jiné plyny
- ☞ rozvody - instalace stlačeného vzduchu
- ☞ nízkotlaké parní rozvody
- ☞ instalace rozvodů klimatizace
- ☞ pro sanitární zařízení
- ☞ Inox Press fitinky jsou vhodné jak pro viditelné instalace, tak i pro instalace pod omítku

Použité materiály:

- ☞ všechny fitinky Inox Press jsou vyrobeny výhradně z nerezové oceli AISI 316L
- ☞ materiál je velmi vhodný pro použití v potrubních systémech pro domácí použití
- ☞ je velmi odolný vůči korozivním látkám obsažených ve vodě
- ☞ tato nerezová ocel je celosvětově uznávána jako velmi vhodná pro použití ve styku s pitnou vodou
- ☞ trubky a tvarovky jsou dodávány žíhané při vysoké teplotě v inertní atmosféře, za účelem zlepšení jejich charakteristické odolnosti proti korozi a stárnutí

Vodo-těsnost a plyno-těsnost:

- ☞ O-kroužky EPDM, které jsou vkládány do fitinek Inox Press garantují vodo-těsnost spoje
- ☞ tyto O-kroužky vyrobeny z 70 Shore EPDM, jsou odolné proti stárnutí a působení běžných přísad používaných při úpravě pitné vody
- ☞ speciální O-kroužky pro použití na plyn jsou dostupné na přání

Technická charakteristika:

- ☞ maximální pracovní tlak: 16 bar
- ☞ maximální pracovní teplota: 95 °C

Návod - instalace:

- 1) uřízněte potrubí na požadovanou délku
- 2) odstraňte nečistoty po řezání (zabráňte tím možné poničení O kroužku)
- 3) zkontrolujte a ujistěte se, že O-kroužek je správně umístěn v Inox Press lisovací fitince
- 4) vtlačte potrubí do Inox Press fitinky (až po doraz)
- 5) pro kontrolu si označte potrubí před lisováním
- 6) vezměte správný průměr čelistí
- 7) otevřete čelisti lisovacích kleští a vložte lisovací fitinku se zasunutou trubkou
- 8) zalisujte fitinku lisovacími kleštěmi
- 9) zkontrolujte kompletní spoj



Potrubi
Inox Press - lisovací tvarovka
materiál: nerezová ocel DIN 1.4404 (AISI 316L)

I000



INOX PRESS - Tubes

Objednací kód	DN	rozměr	vnitřní Ø	kg
I000-015-316L	15	15 x 1	13	0,351
I000-018-316L	18	18 x 1	16	0,426
I000-022-316L	22	22 x 1,2	19,6	0,625
I000-028-316L	28	28 x 1,2	25,6	0,805
I000-035-316L	35	35 x 1,5	32	1,258
I000-042-316L	42	42 x 1,5	39	1,521
I000-054-316L	54	54 x 1,5	51	1,972
I000-076-316L	76,1	76,1 x 2	72,1	3,711
I000-088-316L	88,9	88,9 x 2	84,9	4,352
I000-108-316L	108	108 x 2	104	5,308

Těsnící O-kroužek
Inox Press
materiál: EPDM (černé) (materiál FKM, NBR na přání)

I39E



INOX PRESS - OR seal ring

Objednací kód	DN			
I39E-015-EPDM	15			
I39E-018-EPDM	18			
I39E-022-EPDM	22			
I39E-028-EPDM	28			
I39E-035-EPDM	35			
I39E-042-EPDM	42			
I39E-054-EPDM	54			
I39E-076-EPDM	76,1			
I39E-088-EPDM	88,9			
I39E-108-EPDM	108			

Adaptér - příruba PN 16 / F (lis.)
Inox Press - lisovací tvarovka
materiál: nerezová ocel DIN 1.4404 (AISI 316L)

I279



INOX PRESS - Adaptor flange PN 16 / F (press)

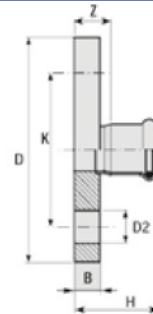

Objednací kód	DN (lis.)	DN (příruba)	Z	H	B	D	D2	Počet otvorů v přírubě	K
I279-015-015-316L	15	15	18	38	11	95	14	4	65
I279-018-015-316L	15	15	19	39	11	95	14	4	65
I279-022-020-316L	20	20	20	41	12	105	14	4	75
I279-028-025-316L	25	25	23	46	14	115	14	4	85
I279-035-032-316L	32	32	24	50	15	140	18	4	100
I279-042-040-316L	40	40	25	55	16	150	18	4	110
I279-054-050-316L	50	50	28	63	18	165	18	4	125
I279-076-065-316L	65	65	42	97	18	185	18	4	145
I279-088-080-316L	80	80	45	105	20	200	18	8	160
I279-108-100-316L	100	100	48	123	20	220	18	8	180

Spojení kónicky těsněné - F/F

Inox Press - lisovací tvarovka

materiál: nerezová ocel DIN 1.4404 (AISI 316L)

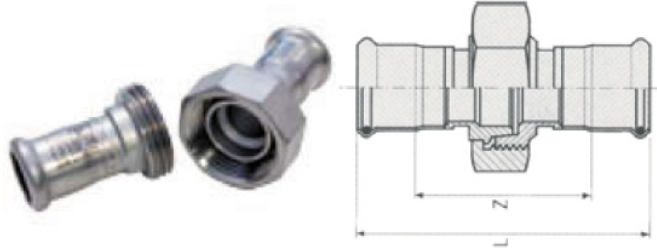
I020

INOX PRESS - Conical union - F/F

Objednací kód	DN	L	Z
I020-015-316L	15	96	56
I020-018-316L	18	97	57
I020-022-316L	22	99	57
I020-028-316L	28	116	70
I020-035-316L	35	123	71
I020-042-316L	42	138	78
I020-054-316L	54	154	84

Spojka - F/F

Inox Press - lisovací tvarovka

materiál: nerezová ocel DIN 1.4404 (AISI 316L)

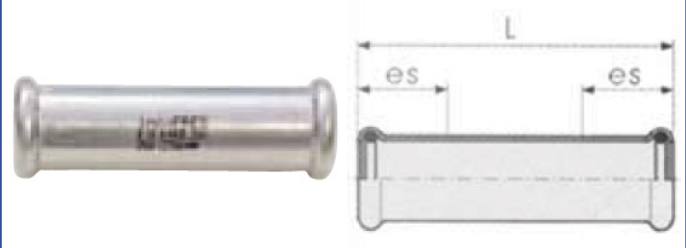
I022

INOX PRESS - Slip coupling - F/F

Objednací kód	DN	L	ES
I022-015-316L	15	80	25
I022-018-316L	18	80	25
I022-022-316L	22	84	25
I022-028-316L	28	91	30
I022-035-316L	35	102	30
I022-042-316L	42	120	40
I022-054-316L	54	140	40
I022-076-316L	76,1	230	60
I022-088-316L	88,9	260	70
I022-108-316L	108	310	80

Spojka - F/F

Inox Press - lisovací tvarovka

materiál: nerezová ocel DIN 1.4404 (AISI 316L)

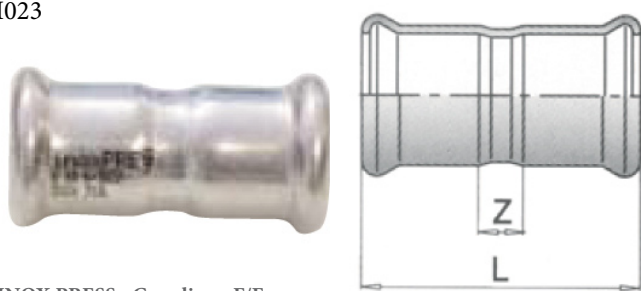
I023

INOX PRESS - Coupling - F/F

Objednací kód	DN	L	Z
I023-015-316L	15	49	9
I023-018-316L	18	50	10
I023-022-316L	22	53	11
I023-028-316L	28	56	10
I023-035-316L	35	63	10
I023-042-316L	42	72	12
I023-054-316L	54	83	13
I023-076-316L	76,1	142	32
I023-088-316L	88,9	166	46
I023-108-316L	108	203	41

Zátka - F

Inox Press - lisovací tvarovka

materiál: nerezová ocel DIN 1.4404 (AISI 316L)

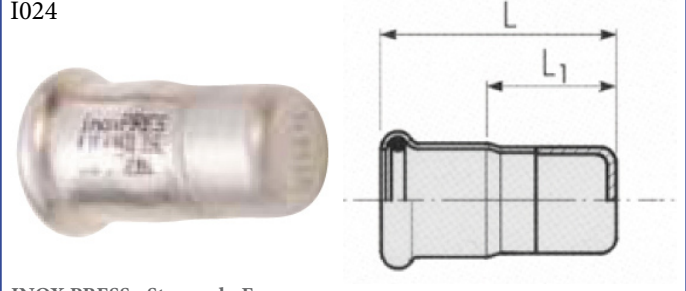
I024

INOX PRESS - Stop end - F

Objednací kód	DN	L	L1
I024-015-316L	15	44	24
I024-018-316L	18	44	24
I024-022-316L	22	45	24
I024-028-316L	28	48	25
I024-035-316L	35	52	26
I024-042-316L	42	56	26
I024-054-316L	54	62	27
I024-076-316L	76,1	93	38
I024-088-316L	88,9	99	39
I024-108-316L	108	117	42

Adaptér - konektor pro ventil F (lis.) / vnitřní závit BSP
Inox Press - lisovací tvarovka
materiál: nerezová ocel DIN 1.4404 (AISI 316L)

I025



INOX PRESS - Valve connector F (press) / female thread BSP

Adaptér - F (lis.) / vnitřní závit BSP
Inox Press - lisovací tvarovka
materiál: nerezová ocel DIN 1.4404 (AISI 316L)

I027

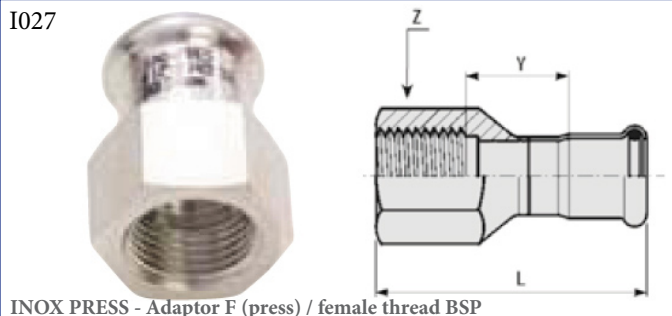

INOX PRESS - Adaptor F (press) / female thread BSP

Objednávací kód	DN	L	Z
I025-015-015-316L	15 x 1/2"	50	27
I025-015-020-316L	15 x 3/4"	56	30
I025-018-015-316L	18 x 1/2"	57	27
I025-018-020-316L	18 x 3/4"	50	30
I025-022-025-316L	22 x 1"	52	36
I025-028-032-316L	28 x 1 1/4"	57	46
I025-035-040-316L	35 x 1 1/2"	63	52
I025-042-050-316L	42 x 2"	68	64
I025-054-065-316L	54 x 2 1/2"	77	81

Objednávací kód	DN	L	Z	Y
I027-015-015-316L	15 x 1/2"	38	27	
I027-018-015-316L	18 x 1/2"	38	27	
I027-022-015-316L	22 x 1/2"	39	32	
I027-022-020-316L	22 x 3/4"	40	32	
I027-022-025-316L	22 x 1"	43	43	
I027-028-020-316L	28 x 3/4"	42	38	
I027-028-025-316L	28 x 1"	45	41	
I027-028-032-316L	28 x 1 1/4"	48	46	
I027-035-025-316L	35 x 1"	64	38	19
I027-035-032-316L	35 x 1 1/4"	75	46	27
I027-042-032-316L	42 x 1 1/4"	71	46	20
I027-042-040-316L	42 x 1 1/2"	79	55	27
I027-054-050-316L	54 x 2"	97	70	36

Adaptér - F (lis.) / vnější závit BSP
Inox Press - lisovací tvarovka
materiál: nerezová ocel DIN 1.4404 (AISI 316L)

I028



INOX PRESS - Adaptor F (press) / male thread BSP

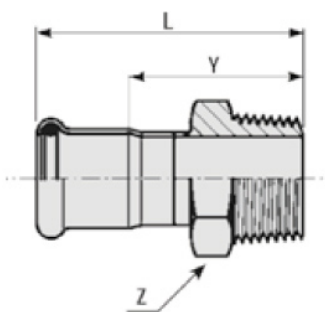

Objednávací kód	DN	L	Z	Y
I028-015-010-316L	15 x 3/8"	38	24	18
I028-015-015-316L	15 x 1/2"	41	24	21
I028-015-020-316L	15 x 3/4"	43	30	23
I028-018-015-316L	18 x 1/2"	41	27	21
I028-018-020-316L	18 x 3/4"	44	30	24
I028-022-015-316L	22 x 1/2"	42	32	21
I028-022-020-316L	22 x 3/4"	44	32	23
I028-022-025-316L	22 x 1"	46	36	25
I028-028-020-316L	28 x 3/4"	47	38	24
I028-028-025-316L	28 x 1"	48	38	25
I028-028-032-316L	28 x 1 1/4"	53	46	30
I028-035-025-316L	35 x 1"	68	41	42

Objednávací kód	DN	L	Z	Z
I028-035-032-316L	35 x 1 1/4"	72	46	46
I028-035-025-316L	35 x 1"	68	41	42
I028-035-032-316L	35 x 1 1/4"	72	46	46
I028-035-040-316L	35 x 1 1/2"	75	55	49
I028-042-032-316L	42 x 1 1/4"	77	50	47
I028-042-040-316L	42 x 1 1/2"	77	55	47
I028-054-040-316L	54 x 1 1/2"	85	65	50
I028-054-050-316L	54 x 2"	89	65	54
I028-076-065-316L	76,1x2 1/2"	124	80	69
I028-088-080-316L	88,9 x 3"	138	95	78
I028-108-100-316L	108 x 4"			

Redukce - M (lis.) / F (lis.)

Inox Press - lisovací tvarovka

materiál: nerezová ocel DIN 1.4404 (AISI 316L)

I029

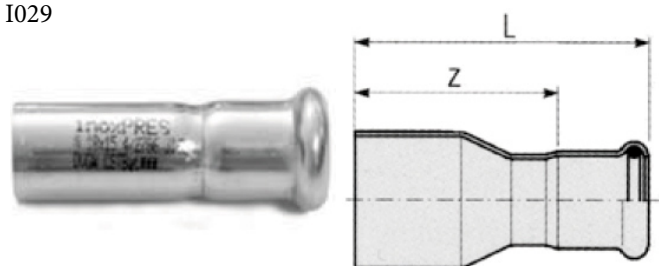

INOX PRESS - Reducer M/F

Objednáací kód	DN	L	Z
I029-018-015-316L	18 x 15	57	37
I029-022-015-316L	22 x 15	64	44
I029-022-018-316L	22 x 18	60	40
I029-028-015-316L	28 x 15	77	57
I029-028-018-316L	28 x 18	75	55
I029-028-022-316L	28 x 22	65	44
I029-035-015-316L	35 x 15	84	64
I029-035-018-316L	35 x 18	81	61
I029-035-022-316L	35 x 22	80	59
I029-035-028-316L	35 x 28	71	48
I029-042-015-316L	42 x 15	87	67
I029-042-018-316L	42 x 18	87	67
I029-042-022-316L	42 x 22	97	76
I029-042-028-316L	42 x 28	93	70
I029-042-035-316L	42 x 35	81	55
I029-054-015-316L	54 x 15	98	78
I029-054-018-316L	54 x 18	98	78
I029-054-022-316L	54 x 22	99	78
I029-054-028-316L	54 x 28	109	86
I029-054-035-316L	54 x 35	108	82
I029-054-042-316L	54 x 42	98	68
I029-076-054-316L	76 x 54	147	112
I029-088-054-316L	88 x 54	160	125
I029-088-076-316L	88 x 76	184	129
I029-108-054-316L	108 x 54	178	143
I029-108-076-316L	108 x 76	203	148
I029-108-088-316L	108 x 88	207	147

Most - M (lis.) / M (lis.)

Inox Press - lisovací tvarovka

materiál: nerezová ocel DIN 1.4404 (AISI 316L)

I030

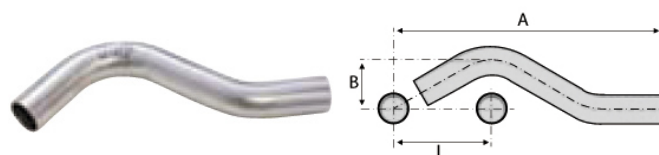

INOX PRESS - Bridge M (press) / M (press)

Objednáací kód	DN	L	A	B
I030-015-316L	15	57	158	42
I030-018-316L	18	60	166	44
I030-022-316L	22	76	189	48
I030-028-316L	28	74	201	54

T-kus - F/F/F (lis.)

Inox Press - lisovací tvarovka

materiál: nerezová ocel DIN 1.4404 (AISI 316L)

I032

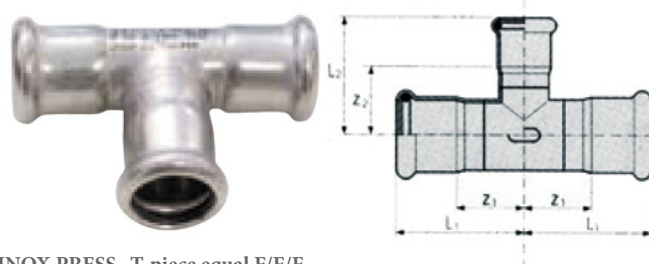

INOX PRESS T-piece equal F/F/F

Objednáací kód	DN	L1	L2	Z1	Z2
I032-015-316L	15	34	39	14	19
I032-018-316L	18	37	41	16	21
I032-022-316L	22	39	45	18	24
I032-028-316L	28	44	50	21	27
I032-035-316L	35	51	57	25	31
I032-042-316L	42	59	65	28	35
I032-054-316L	54	70	77	34	42
I032-076-316L	76,1	108	118	52	63
I032-088-316L	88,9	132	131	72	71
I032-108-316L	108	155	159	74	84

T-kus adaptér - F (lis.) / F (BSP) / F (lis.)

Inox Press - lisovací tvarovka

materiál: nerezová ocel DIN 1.4404 (AISI 316L)

I033

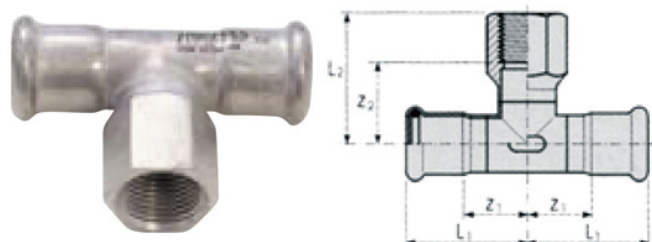

INOX PRESS T-piece adaptor F (press) / F (BSP) / F (press)

T-kus redukovaný - F/F/F (lis.)

Inox Press - lisovací tvarovka

materiál: nerezová ocel DIN 1.4404 (AISI 316L)

I034



INOX PRESS T-piece reducing F/F/F

Objednáací kód	DN	L1	L2	Z1	Z2
I033-015-015-316L	15 x 1/2" x 15	34	40	13	25
I033-018-015-316L	18 x 1/2" x 18	37	42	16	27
I033-018-020-316L	18 x 3/4" x 18	37	45	16	28
I033-022-015-316L	22 x 1/2" x 22	39	44	18	29
I033-022-020-316L	22 x 3/4" x 22	39	47	18	31
I033-028-015-316L	28 x 1/2" x 28	44	47	21	32
I033-028-020-316L	28 x 3/4" x 28	44	50	21	33
I033-028-025-316L	28 x 1" x 28	44	53	21	34
I033-035-015-316L	35 x 1/2" x 35	51	51	25	36
I033-035-020-316L	35 x 3/4" x 35	51	54	25	37
I033-035-025-316L	35 x 1" x 35	51	47	22	28
I033-042-015-316L	42 x 1/2" x 42	59	54	28	39
I033-042-020-316L	42 x 3/4" x 42	59	57	28	41
I033-054-015-316L	54 x 1/2" x 54	70	61	34	46
I033-054-020-316L	54 x 3/4" x 54	70	64	34	48
I033-054-050-316L	54 x 2" x 54	70	81	34	55
I033-076-020-316L	76,1 x 3/4" x 76,1	108	77	52	60
I033-076-050-316L	76,1 x 2" x 76,1	108	93	52	67
I033-088-020-316L	88,9 x 3/4" x 88,9	132	84	72	67
I033-088-050-316L	88,9 x 2" x 88,9	132	100	72	74
I033-108-020-316L	108 x 3/4" x 108	155	94	74	77
I033-108-050-316L	108 x 2" x 108	155	110	74	84

Objednáací kód	DN	L1	L2	Z1	Z2
I034-018-015-316L	18 x 15 x 18	37	41	16	21
I034-022-015-316L	22 x 15 x 22	39	43	18	23
I034-022-018-316L	22 x 18 x 22	39	44	18	23
I034-028-015-316L	28 x 15 x 28	44	46	21	26
I034-028-018-316L	28 x 18 x 28	44	46	21	26
I034-028-022-316L	28 x 22 x 28	44	47	21	26
I034-035-015-316L	35 x 15 x 35	51	49	25	29
I034-035-018-316L	35 x 18 x 35	51	50	25	30
I034-035-022-316L	35 x 22 x 35	51	51	25	30
I034-035-028-316L	35 x 28 x 35	51	54	25	31
I034-042-022-316L	42 x 22 x 42	59	54	28	33
I034-042-028-316L	42 x 28 x 42	59	57	28	34
I034-042-035-316L	42 x 35 x 42	59	61	28	35
I034-054-022-316L	54 x 22 x 54	70	62	34	41
I034-054-028-316L	54 x 28 x 54	70	65	34	42
I034-054-035-316L	54 x 35 x 54	70	68	34	42
I034-054-042-316L	54 x 42 x 54	70	72	34	42
I034-076-022-316L	76,1 x 22 x 76,1	108	74	52	53
I034-076-028-316L	76,1 x 28 x 76,1	108	77	52	54
I034-076-035-316L	76,1 x 35 x 76,1	108	80	52	54
I034-076-042-316L	76,1 x 42 x 76,1	108	84	52	54
I034-076-054-316L	76,1 x 54 x 76,1	108	90	52	55
I034-088-022-316L	88,9 x 22 x 88,9	132	81	72	60
I034-088-028-316L	88,9 x 28 x 88,9	132	84	72	61
I034-088-035-316L	88,9 x 35 x 88,9	132	88	72	62
I034-088-042-316L	88,9 x 42 x 88,9	132	91	72	61
I034-088-054-316L	88,9 x 54 x 88,9	132	97	72	62
I034-088-076-316L	88,9 x 76,1 x 88,9	132	125	72	70
I034-108-022-316L	108 x 22 x 108	155	91	74	70
I034-108-028-316L	108 x 28 x 108	155	94	74	71
I034-108-035-316L	108 x 35 x 108	155	97	74	71
I034-108-042-316L	108 x 42 x 108	155	101	74	71
I034-108-054-316L	108 x 54 x 108	155	107	74	72
I034-108-076-316L	108 x 76,1 x 108	155	135	74	80
I034-108-088-316L	108 x 88,9 x 108	155	141	74	81

Koleno 45° F/ F

Inox Press - lisovací tvarovka

materiál: nerezová ocel DIN 1.4404 (AISI 316L)

I045

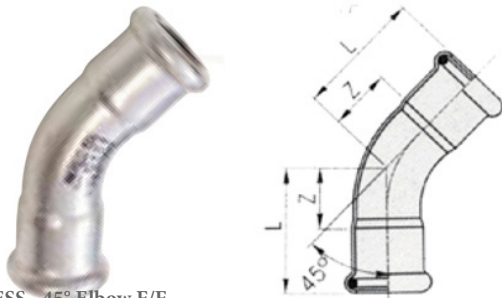

INOX PRESS - 45° Elbow F/F

Objednáací kód	D	L	Z
I045-015-316L	15	36	16
I045-018-316L	18	37	17
I045-022-316L	22	41	20
I045-028-316L	28	47	24
I045-035-316L	35	54	28
I045-042-316L	42	75	45
I045-054-316L	54	91	56
I045-076-316L	76,1	133	78
I045-088-316L	88,9	144	84
I045-108-316L	108	169	94

Koleno 45° M/F

Inox Press - lisovací tvarovka

materiál: nerezová ocel DIN 1.4404 (AISI 316L)

I046

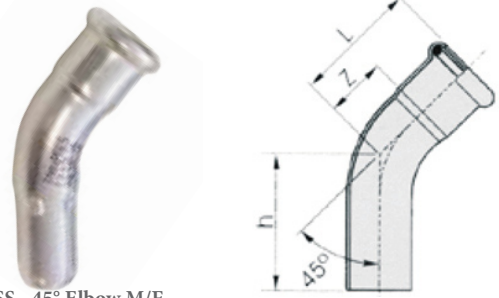

INOX PRESS - 45° Elbow M/F

Objednáací kód	D	L	H	Z
I046-015-316L	15	36	49	16
I046-018-316L	18	37	43	17
I046-022-316L	22	41	48	20
I046-028-316L	28	48	55	24
I046-035-316L	35	55	68	29
I046-042-316L	42	75	96	45
I046-054-316L	54	91	107	56
I046-076-316L	76,1	133	143	78
I046-088-316L	88,9	144	160	84
I046-108-316L	108	169	186	94

Koleno 90° F/ F

Inox Press - lisovací tvarovka

materiál: nerezová ocel DIN 1.4404 (AISI 316L)

I090

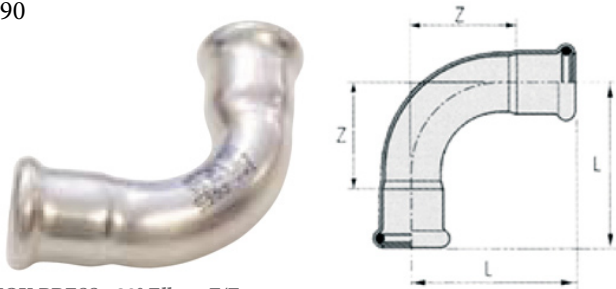

INOX PRESS - 90° Elbow F/F

Objednáací kód	D	L	Z
I090-015-316L	15	50	30
I090-018-316L	18	54	34
I090-022-316L	22	60	39
I090-028-316L	28	73	50
I090-035-316L	35	86	60
I090-042-316L	42	112	82
I090-054-316L	54	138	103
I090-076-316L	76,1	160	105
I090-088-316L	88,9	182	122
I090-108-316L	108	220	145

Koleno 90° M/F

Inox Press - lisovací tvarovka

materiál: nerezová ocel DIN 1.4404 (AISI 316L)

I091

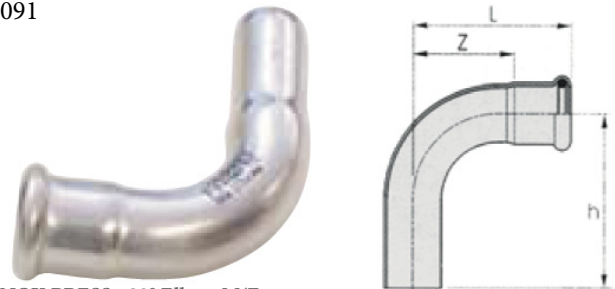

INOX PRESS - 90° Elbow M/F

Objednáací kód	D	L	H	Z
I091-015-316L	15	50	63	30
I091-018-316L	18	54	63	34
I091-022-316L	22	60	71	39
I091-028-316L	28	73	81	50
I091-035-316L	35	86	100	60
I091-042-316L	42	112	133	82
I091-054-316L	54	138	152	103
I091-076-316L	76,1	160	180	105
I091-088-316L	88,9	182	197	122
I091-108-316L	108	220	236	145

Adaptér - koleno 90° - F (lis.) / vnitřní závit BSP
 Inox Press - lisovací tvarovka
 materiál: nerezová ocel DIN 1.4404 (AISI 316L)

I092

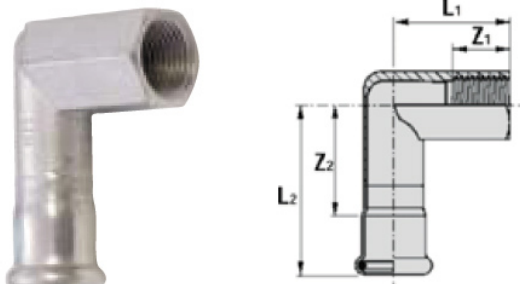

INOX PRESS - 90° Elbow F (press) / female thread BSP

Objednávací kód	DN	L1	L2	Z1	Z2
I092-015-015-316L	15 x 1/2"	28	57	15	37
I092-015-020-316L	15 x 3/4"	34	38	15	18
I092-018-015-316L	18 x 1/2"	39	58	15	38
I092-022-020-316L	22 x 3/4"	46	61	19	40
I092-028-015-316L	28 x 1/2"	44	62	15	39
I092-028-025-316L	28 x 1"	54	68	19	45
I092-035-032-316L	35 x 1 1/4"	63	75	21	49

Adaptér - koleno 90° F (lis.) / vnější závit BSP
 Inox Press - lisovací tvarovka
 materiál: nerezová ocel DIN 1.4404 (AISI 316L)

I093

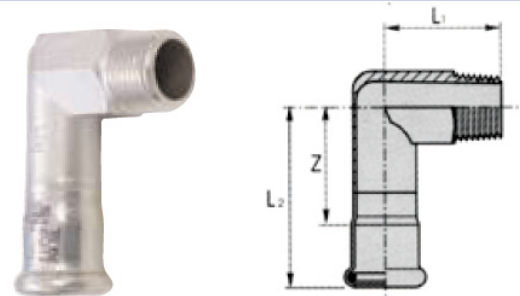

INOX PRESS - 90° Elbow F (press) / male thread BSP

Objednávací kód	DN	L1	L2	Z
I093-015-015-316L	15 x 1/2"	37	57	37
I093-018-015-316L	18 x 1/2"	37	57	38
I093-022-020-316L	22 x 3/4"	39	61	40
I093-028-025-316L	28 x 1"	44	68	45
I093-035-032-316L	35 x 1 1/4"	49	75	49
I093-042-040-316L	42 x 1 1/2"	54	84	54
I093-054-050-316L	54 x 2"	60	95	60

Adaptér - koleno 90° - F (lis.) / vnitřní závit BSP
 Inox Press - lisovací tvarovka (s držákem na stěnu)
 materiál: nerezová ocel DIN 1.4404 (AISI 316L)

I094

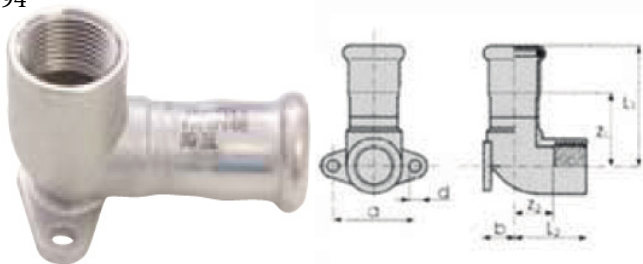

INOX PRESS - 90° Elbow F (press) / female thread BSP with wall plate

Objednávací kód	DN	L1	L2	Z1	Z2	A	B	D
I092-015-015-316L	15 x 1/2"	50	30	30	17	34	13	5
I092-015-020-316L	18 x 1/2"	51	30	31	17	34	13	5
I092-035-032-316L	22 x 3/4"	55	34	34	19	40	17	6