

Koleno 45° DIN  
závit / kužel. hrdlo s maticí  
AISI 304/L, AISI 316/L

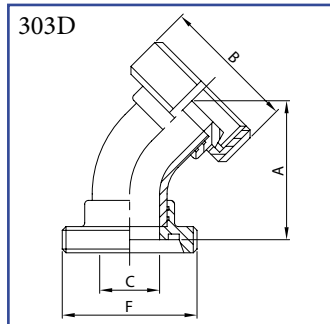

DN	A	B	C	F	kg
25	91,0	63,5	25,0	52-6	0,44
32	100,3	70,0	31,0	58-6	0,56
40	104,5	78,0	37,0	65-6	0,71
50	118,5	92,0	49,0	78-6	0,99
65	124,5	112,0	66,0	95-6	1,61
80	140,7	127,0	81,0	110-4	2,22
100	173,7	148,0	100,0	130-4	3,70

Koleno 45° DIN  
se závitovými konci  
AISI 304/L, AISI 316/L

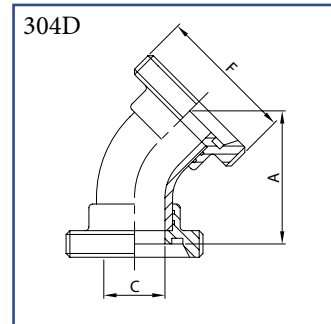

DN	A	C	F	kg
25	96,0	25,0	52-6	0,33
32	105,6	31,0	58-6	0,43
40	110,0	37,0	65-6	0,54
50	124,0	49,0	78-6	0,75
65	130,5	66,0	95-6	1,15
80	146,0	81,0	110-4	1,67
100	180,0	100,0	130-4	2,93

Koleno 90° DIN  
závit / kužel. hrdlo s maticí  
AISI 304/L, AISI 316/L

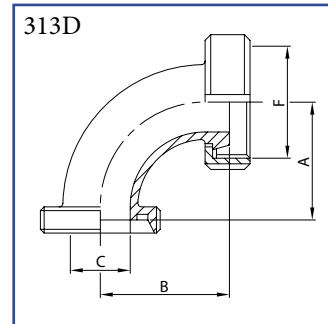

DN	A	B	C	F	kg
25	77,0	77,0	25,0	52-6	0,465
32	85,0	85,0	31,0	58-6	0,615
40	92,0	92,0	37,0	65-6	0,790
50	103,0	103,0	49,0	78-6	1,096
65	117,0	117,0	66,0	95-6	1,730
80	132,0	132,0	81,0	110-4	2,470
100	149,0	149,0	100,0	130-4	3,950

Koleno 90° DIN  
se závitovými konci  
AISI 304/L, AISI 316/L

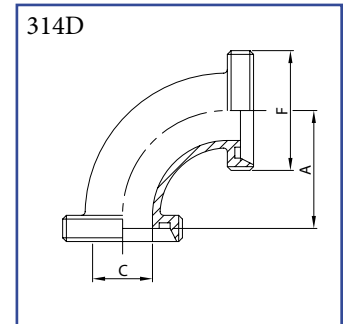

DN	A	C	F	kg
25	77,0	25,0	52-6	0,35
32	85,0	31,0	58-6	0,46
40	92,0	37,0	65-6	0,63
50	103,0	49,0	78-6	0,91
65	117,0	66,0	95-6	1,25
80	132,0	81,0	110-4	1,87
100	149,0	100,0	130-4	3,29

Koleno 90° dlouhé DIN  
závit / kužel. hrdlo s maticí  
AISI 304/L, AISI 316/L

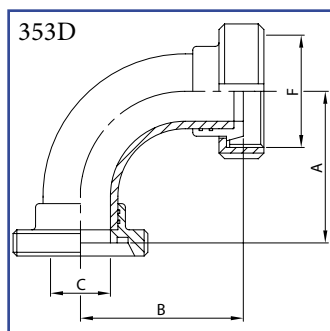

DN	A	B	C	F	kg
25	77,0	77,0	25,0	52-6	0,49
32	85,0	85,0	31,0	58-6	0,63
40	91,0	91,0	37,0	65-6	0,80
50	103,0	103,0	49,0	78-6	1,10
65	117,0	117,0	66,0	95-6	1,785
80	132,0	132,0	81,0	110-4	2,53
100	149,0	149,0	100,0	130-4	3,97

Koleno 90° dlouhé DIN  
se závitovými konci  
AISI 304/L, AISI 316/L

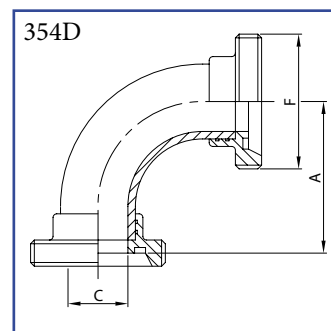

DN	A	C	F	kg
25	77,0	25,0	52-6	0,38
32	85,0	31,0	58-6	0,50
40	91,0	37,0	65-6	0,63
50	103,0	49,0	78-6	0,86
65	117,0	66,0	95-6	1,33
80	132,0	81,0	110-4	1,98
100	149,0	100,0	130-4	3,20

Koleno 180° DIN  
se závitovými konci  
AISI 304/L, AISI 316/L

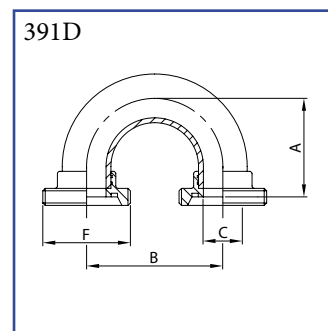

DN	A	B	C	F	kg
25	77,0	100,0	25,0	52-6	0,45
32	85,0	110,0	31,0	58-6	0,58
40	91,0	120,0	37,0	65-6	0,77
50	103,0	140,0	49,0	78-6	0,97
65	117,0	160,0	66,0	95-6	1,73
80	132,0	180,0	81,0	110-4	2,70
100	149,0	220,0	100,0	130-4	4,40

Koleno 180° DIN  
závit / kužel. hrdlo s maticí  
AISI 304/L, AISI 316/L

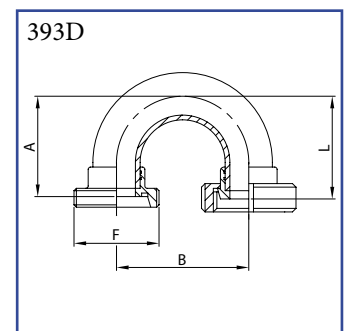

DN	A	B	F	L	kg
25	77,0	100,0	52-6	77,0	0,56
32	85,0	110,0	58-6	85,0	0,71
40	91,0	120,0	65-6	91,0	1,00
50	103,0	140,0	78-6	103,0	1,21
65	117,0	160,0	95-6	117,0	2,19
80	132,0	180,0	110-4	132,0	3,25
100	149,0	220,0	130-4	149,0	5,17