

**METAL/METAL WAFER BUTTERFLY VALVE ( NO TIGHTNESS )  
EXCELLENCE RANGE**

**armat**  
spol. s r.o.  
MADE OF STAINLESS ...



- Size :** DN 40 to 1400 mm
- Ends :** Between flanges PN10/16 and Class 150 (PN20)
- Min Temperature :** - 20°C for carbon steel and -30°C for S.S. type
- Max Temperature :** + 350°C
- Max Pressure :** 16 Bars up to DN300
- Specifications :** Long neck for isolation  
Wafer type  
Crossing stem  
ISO 5211 mounting pad

**Materials :** Carbon or stainless steel body

\*the installation defects and wear defects are not covered by the guarantee

**METAL/METAL WAFER BUTTERFLY VALVE ( NO TIGHTNESS )  
EXCELLENCE RANGE**

**SPECIFICATIONS :**

Long neck for isolation  
 ISO 5211 mounting pad  
 Wafer type  
 Between flanges PN10/16 and Class 150 (PN20) up to DN400 included ( over on request )  
 Between flanges PN10 from DN450 to DN1400  
 Crossing stem  
**No tightness , loss factor : 2% of Kvs**  
 Stainless steel disc up to DN100 included  
 Ductile iron +/- 40 µ epoxy coated disc from DN125 to 300, ductile iron disc rilsan coated +/- 300 µ over for Ref. 1111  
 9 positions lever, with locking device up to DN200 , stop in all positions but non lockable from DN250 to 300  
 Stem extension 75 mm length ( option )  
 Square lever 30x30 mm for special key ( option )

**USE :**

High temperature smokes, powders  
 Min and max Temperature Ts : - 20°C to + 350°C for carbon steel type **Ref.1111**  
 Min and max Temperature Ts : - 30°C to + 350°C\* for stainless steel type **Ref.1112**  
 (\* : higher temperature on request )  
 Max Pressure Ps : 16 bars up to DN300 , 10 bars over  
**Not for steam**

**RANGE :**

With lever from DN 40 to DN 300  
 Naked stem from DN 350 to DN1400  
 IP65 Gear box possible ( **Ref. 1197** ) from DN 40 to DN 1400  
 IP65 chain gear box possible ( **Ref. 1194** ) from DN 40 to DN 500  
 On request, stem extension with special length ( **Ref. 98665** )  
 On request, stainless steel lever and bolting ( **Ref. 9831250-9831264** )

**ENDS :**

Between flanges PN10-PN16 and Class 150 (PN20) up to DN400  
 Between flanges PN10 from DN450 to DN 1400

**TORQUE VALUES ( in Nm without safety coefficient ) at 10 Bars :**

DN	40	50	65	80	100	125	150	200	250	300	350	400
Torque ( Nm )	5	5	10	15	25	45	60	80	110	120	140	160

DN	450	500	600	700	750	800	900	1000	1100	1200	1300	1400
Torque ( Nm )	250	300	450	950	1050	1100	1150	1200	1300	1800	1900	2000

**FLOW COEFFICIENT Kvs ( m3 / h ) :**

DN	40	50	65	80	100	125	150	200	250	300	350	400
Kvs ( m3/h )	70	109	200	334	551	901	1427	2383	3825	5659	8177	10659

DN	450	500	600	700	800	900	1000	1200	1300	1400
Kvs ( m3/h )	12562	16021	22737	32443	43263	53873	64407	97341	119770	129808

**METAL/METAL WAFER BUTTERFLY VALVE ( NO TIGHTNESS )  
EXCELLENCE RANGE**

**HEAD LOSS GRAPH :**

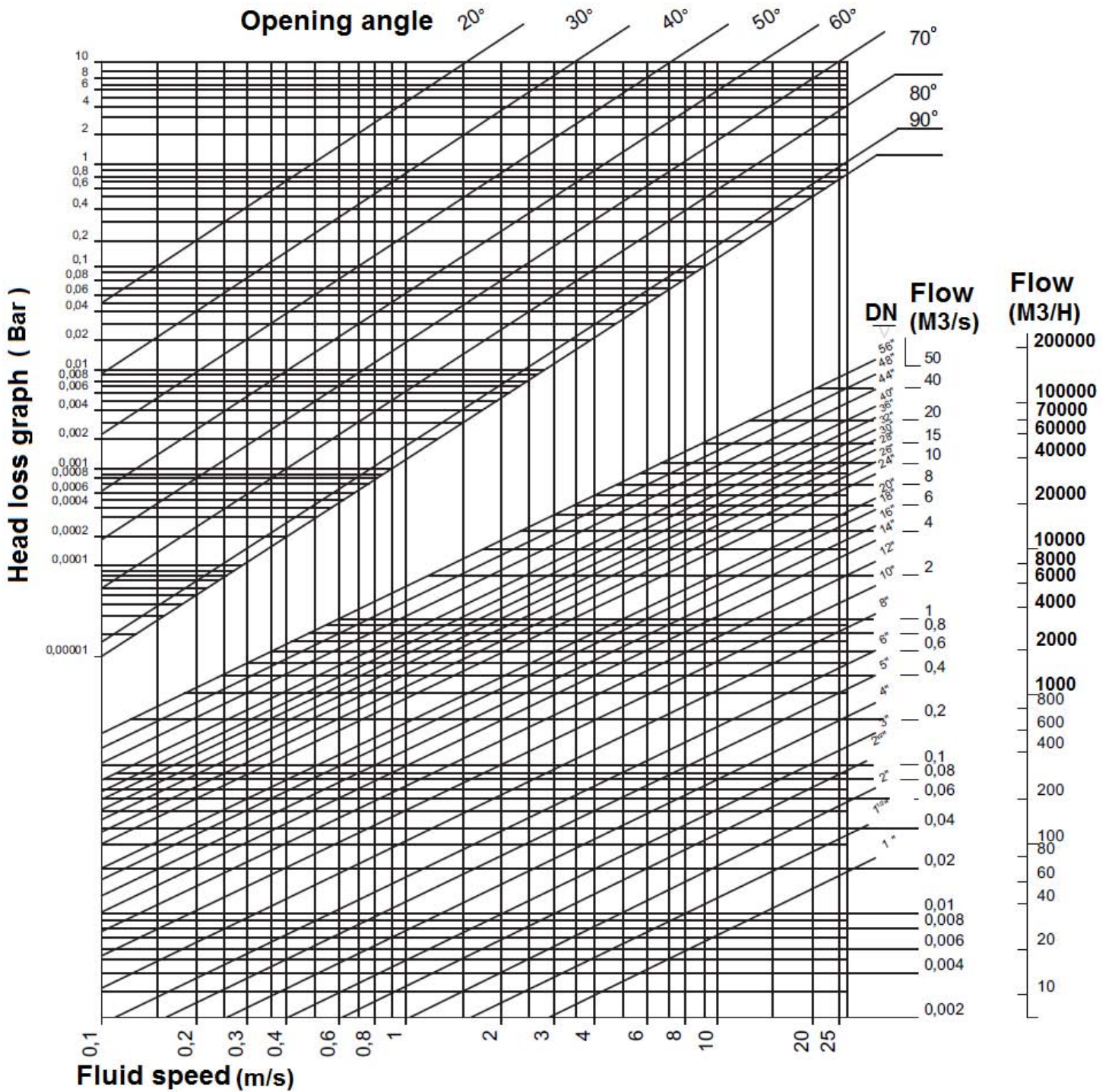

**METAL/METAL WAFER BUTTERFLY VALVE ( NO TIGHTNESS )  
EXCELLENCE RANGE**

MATERIALS DN 40 - 200 :

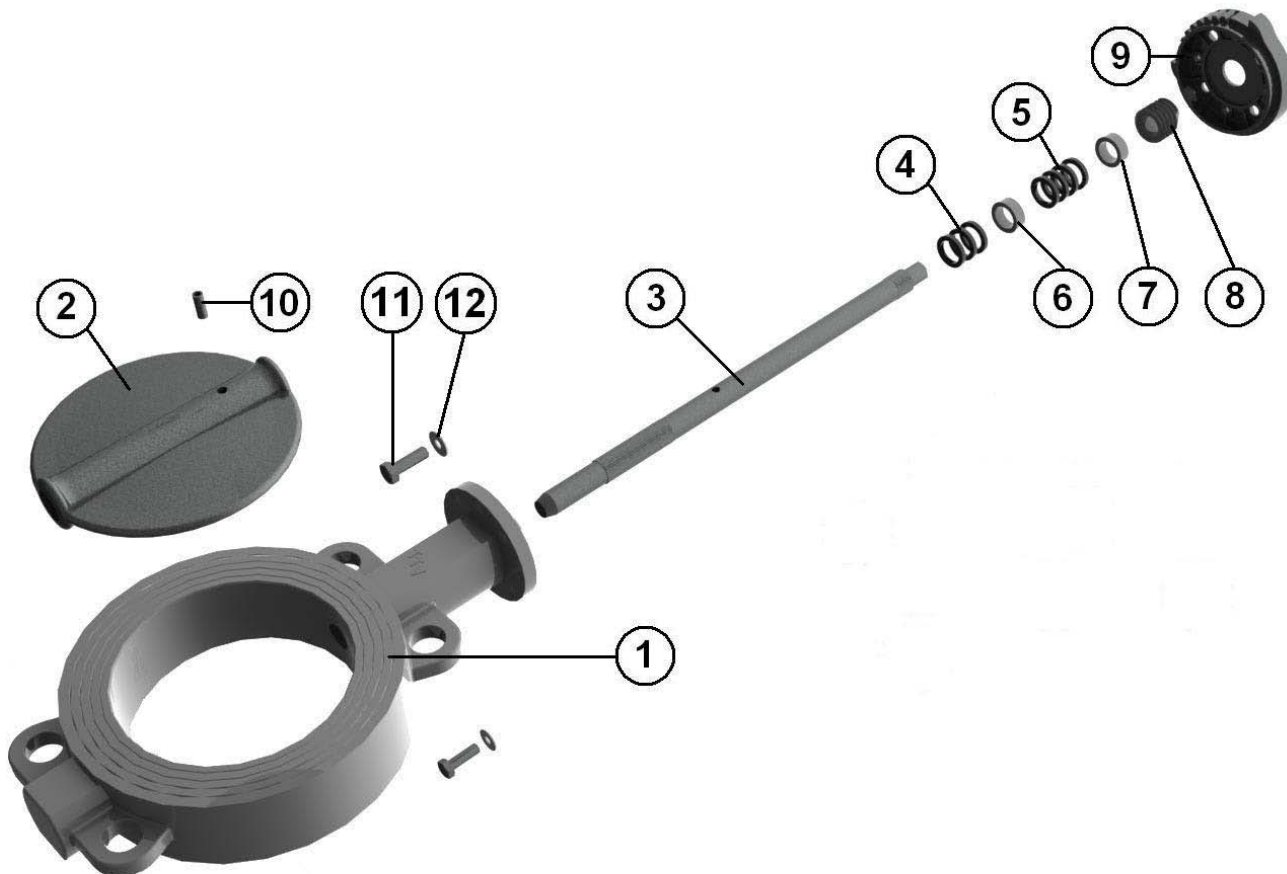

Item	Designation	Materials	
		1111	1112
1	Body	A216 WCB	ASTM A351 CF8M
2	Disc DN40-100	ASTM A351 CF8M	ASTM A351 CF8M
2	Disc DN125-200	Ductile iron EN GJS 500-7	ASTM A351 CF8M
3	Stem	SS 420	SS 316
4	Gasket	FILAM. GRAPHITE	FILAM. GRAPHITE
5	Gasket	FILAM. GRAPHITE	FILAM. GRAPHITE
6	Ring	BRONZE	SS 316
7	Ring	BRONZE	SS 316
8	Socket	5.6	SS 316
9	Plate	ALUMINIUM	ASTM A351 CF8M
10	Pin	ST-34	SS 316
11	Screw	5.6	A4
12	Washer	Steel	SS 316
	Lever	Aluminium ADC10 with epoxy painting 50µ thickness	

**METAL/METAL WAFER BUTTERFLY VALVE ( NO TIGHTNESS )  
EXCELLENCE RANGE**

MATERIALS DN 250 - 400 :

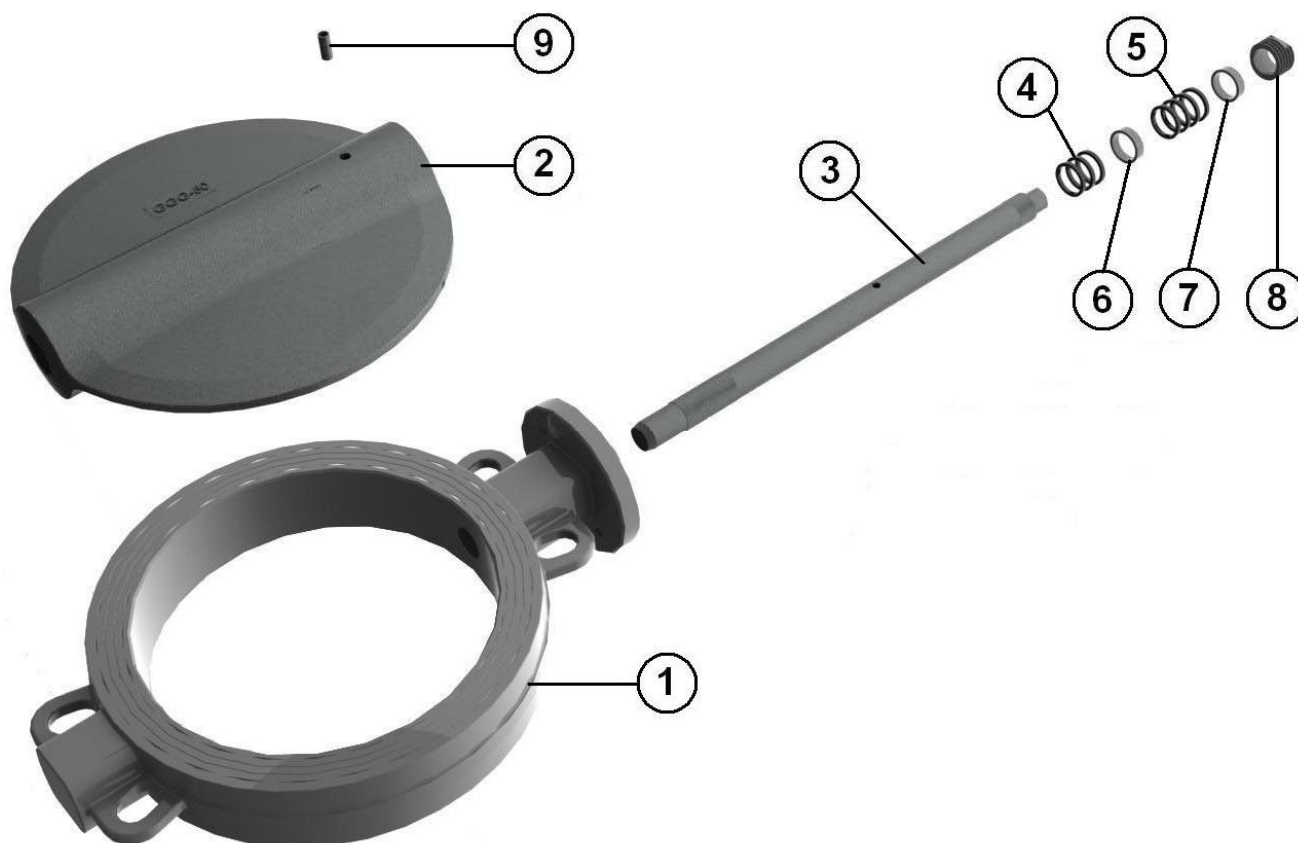

Item	Designation	Materials	
		1111	1112
1	Body	A216 WCB	ASTM A351 CF8M
2	Disc	EN GJS 500-7	ASTM A351 CF8M
3	Stem	SS 420	SS 316
4	Gasket	FILAM. GRAPHITE	FILAM. GRAPHITE
5	Gasket	FILAM. GRAPHITE	FILAM. GRAPHITE
6	Ring	BRONZE	SS 316
7	Ring	BRONZE	SS 316
8	Socket	5.6	SS 316
9	Pin	ST-34	SS 316
Lever ( up to DN300 )		Ductile iron EN GJS-500-7 with epoxy painting 50μ thickness	

**METAL/METAL WAFER BUTTERFLY VALVE ( NO TIGHTNESS )  
EXCELLENCE RANGE**

MATERIALS DN 450 - 1400 :

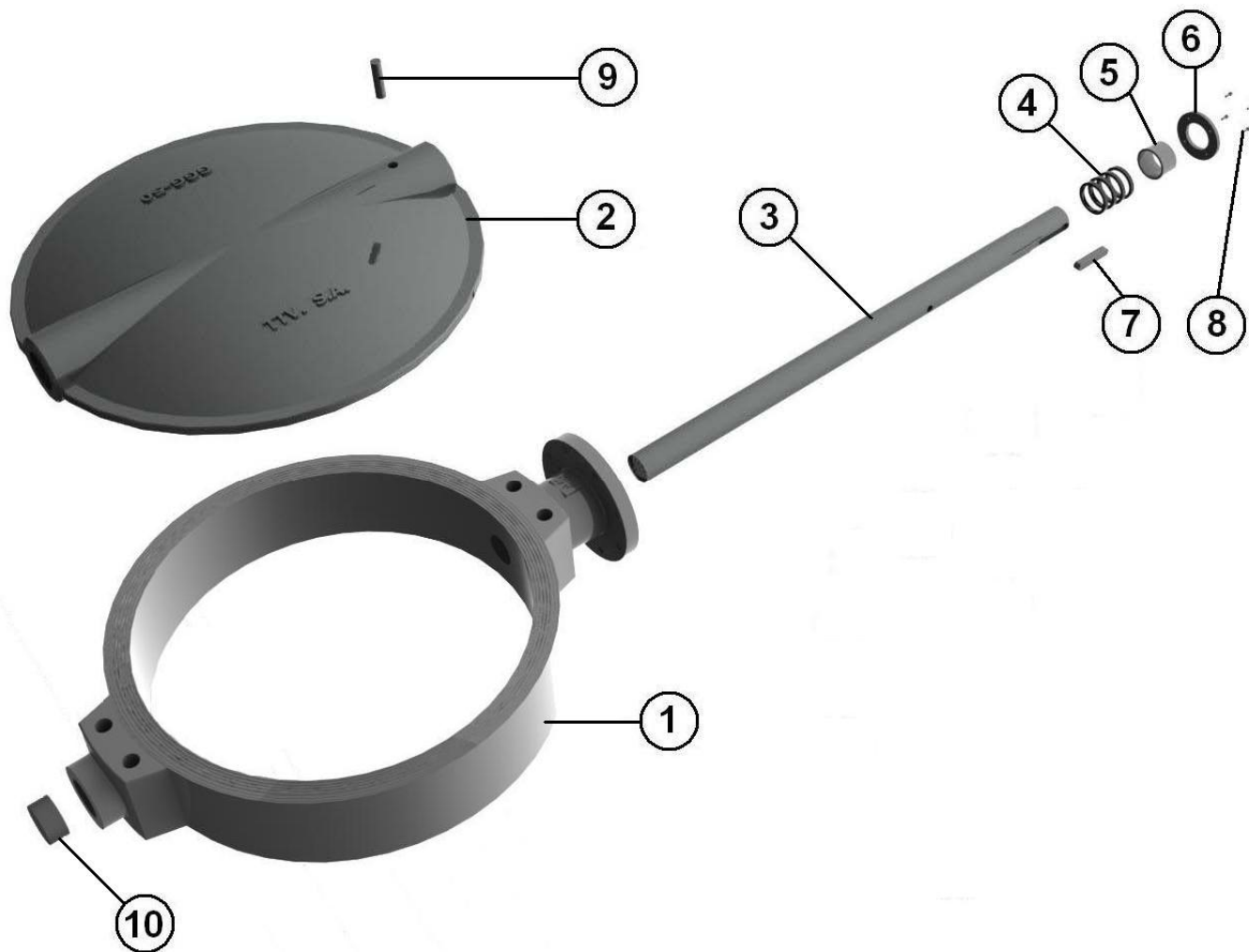

Item	Designation	Materials	
		1111	1112
1	Body	A216 WCB	ASTM A351 CF8M
2	Disc	EN GJS 500-7	ASTM A351 CF8M
3	Stem	SS 420	SS 316
4	Gasket	FILAM. GRAPHITE	FILAM. GRAPHITE
5	Ring	BRONZE	SS 316
6	Ring	BRONZE	SS 316
7	Pin	SS 420	SS 316
8	Screw	5.6	SS 316
9	Pin	ST-34	SS 316
10	Ring	A216 WCB	SS 316

**METAL/METAL WAFER BUTTERFLY VALVE ( NO TIGHTNESS )  
EXCELLENCE RANGE**

GEARBOX MATERIALS REF. 1197 :

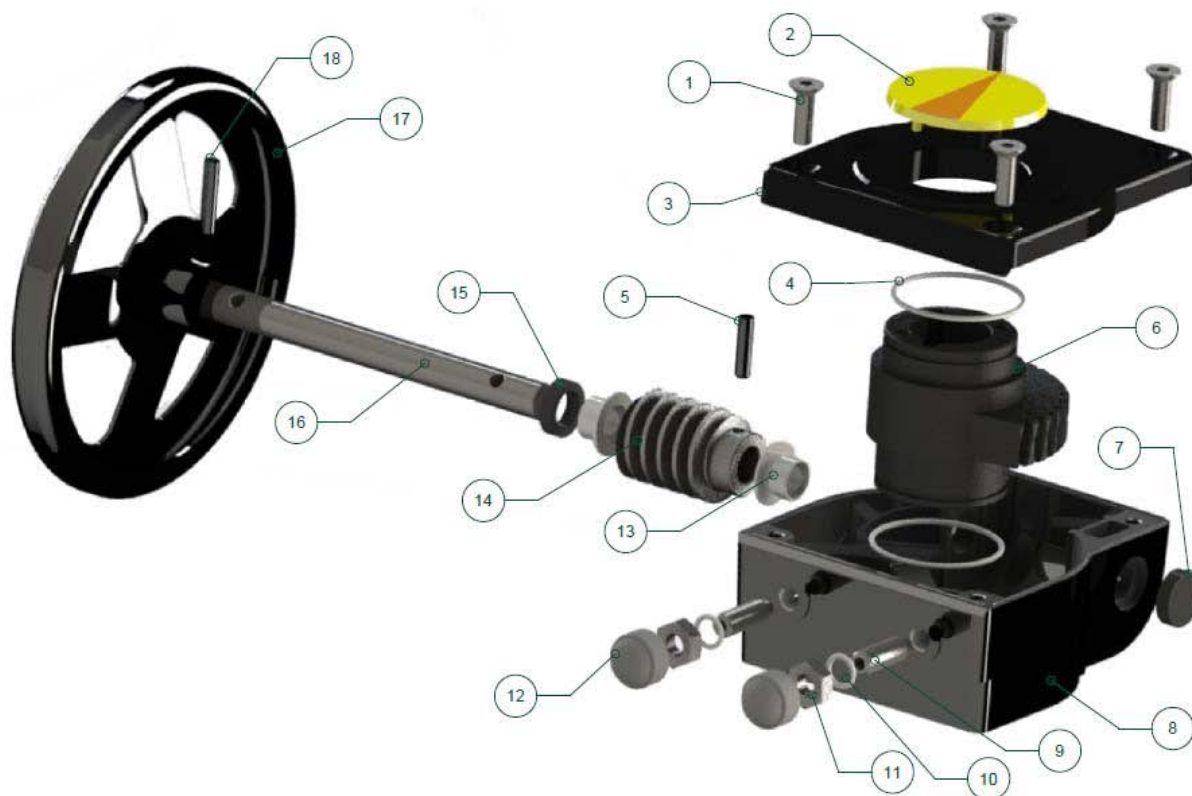

Item	Designation	Materials Ref. 1197
1	Screw	SS 304
2	Indicator	Polypropylene
3	Cover	Aluminium
4	O ring	NBR
5	Pin	Carbon steel
6	Quadrant	Ductile iron EN GJS-400-15
7	Gasket	NBR
8	Body	Aluminium
9	Adjusting bolt	Carbon steel
10	Washer	Galvanized steel
11	Nut	Galvanized steel
12	Cap	NBR 70
13	Bushing	Bronze
14	Worm	Carbon steel 45
15	Gasket	NBR
16	Shaft	Carbon steel 45
17	Handwheel	Carbon steel
18	Pin	Carbon steel

**METAL/METAL WAFER BUTTERFLY VALVE ( NO TIGHTNESS )  
EXCELLENCE RANGE**

SIZE PN10 ( in mm ) :

Valves DN 40 - 200 :

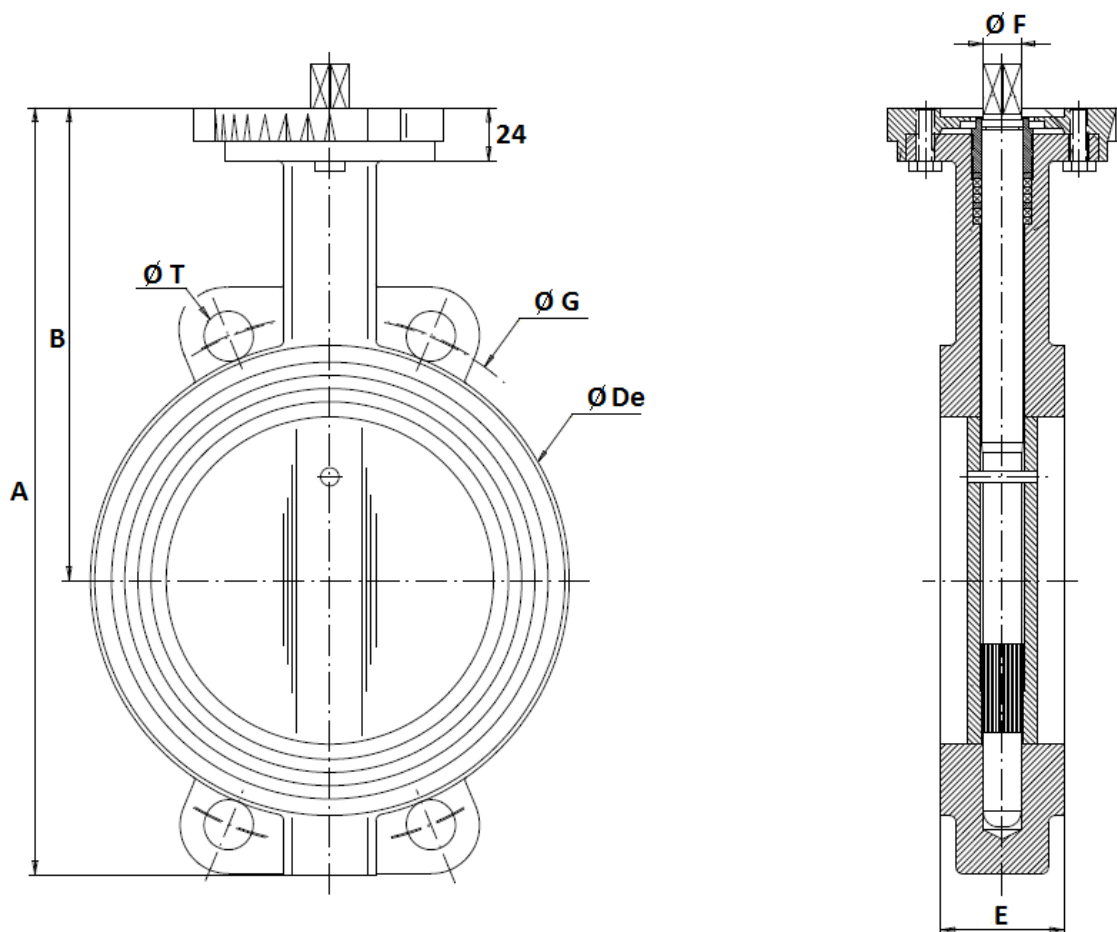

Ref.	DN	40	50	65	80	100	125	150	200
1111 1112	A	205	228	248	265	298	331	349	430
	B	140	156	161	169	187	206	215	255
	Ø De	82	102	119	135	155	185	208	270
	E	33	43	46	46	52	56	56	60
	Ø F	9.5	9.5	12	14	14	17	17	21
	Ø G	110	125	145	160	180	210	240	295
	Ø T	18	18	18	18	18	18	18	23
1111	Weight (Kg)	3.1	4.27	5.27	5.78	7.4	10.15	11.74	19.6
1112	Weight (Kg)	3.07	4.57	4.89	5.95	7.58	10.22	12.23	19



**METAL/METAL WAFER BUTTERFLY VALVE ( NO TIGHTNESS )  
EXCELLENCE RANGE**

SIZE PN10 ( in mm ) :

Valves DN 250 -400 :

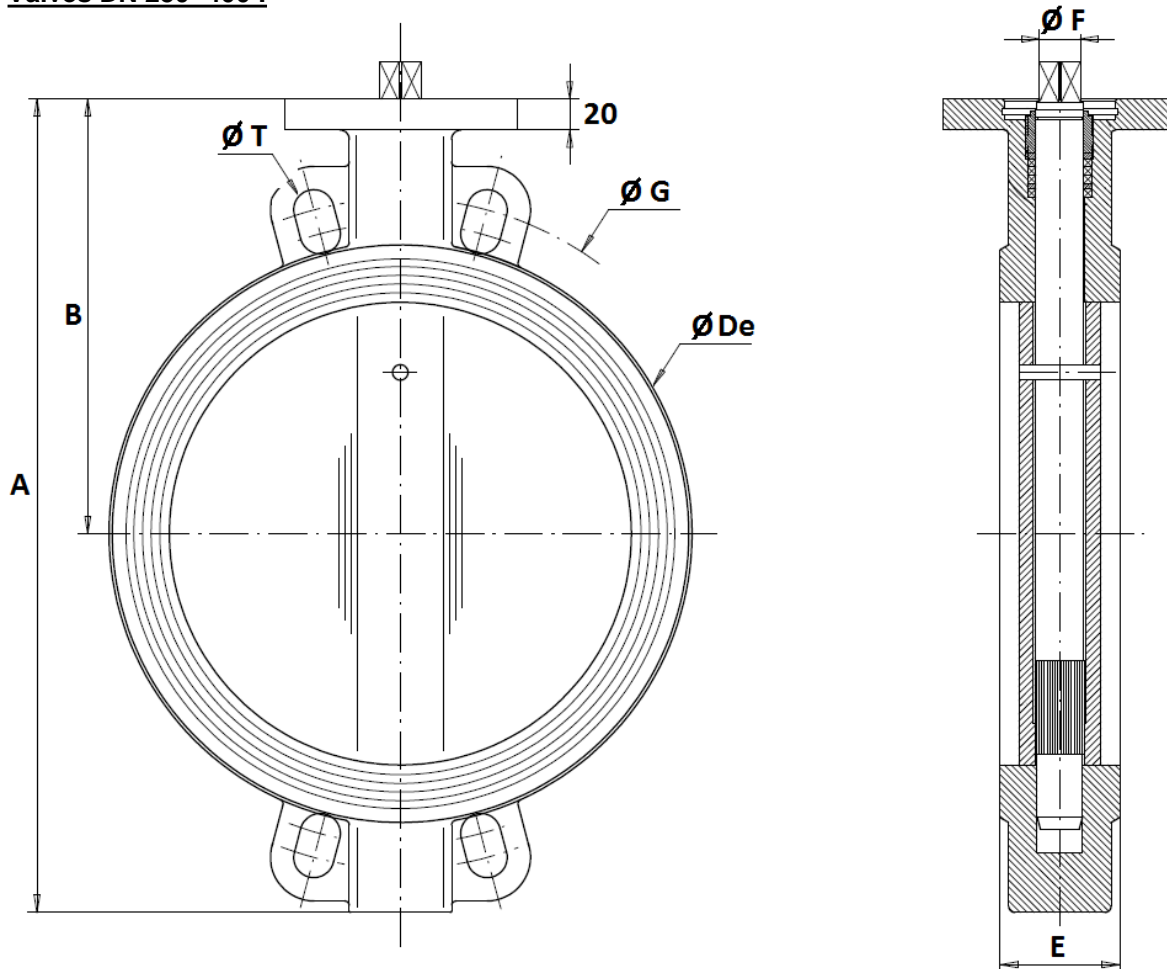

Ref.	DN	250	300	350	400
1111	A	461	524	570	644
	B	248	280	300	340
1112	Ø De	328	381	437	486
	E	68	78	78	102
	Ø F	23	26.5	26.5	33
	Ø G	350	400	460	515
	Ø T	23	23	23	27
1111	Weight (Kg)	30	40	54	75
1112	Weight (Kg)	30	40	54	75

**METAL/METAL WAFER BUTTERFLY VALVE ( NO TIGHTNESS )  
EXCELLENCE RANGE**

STANDARD LEVERS SIZE ( in mm ) :

DN 32 – 200 :

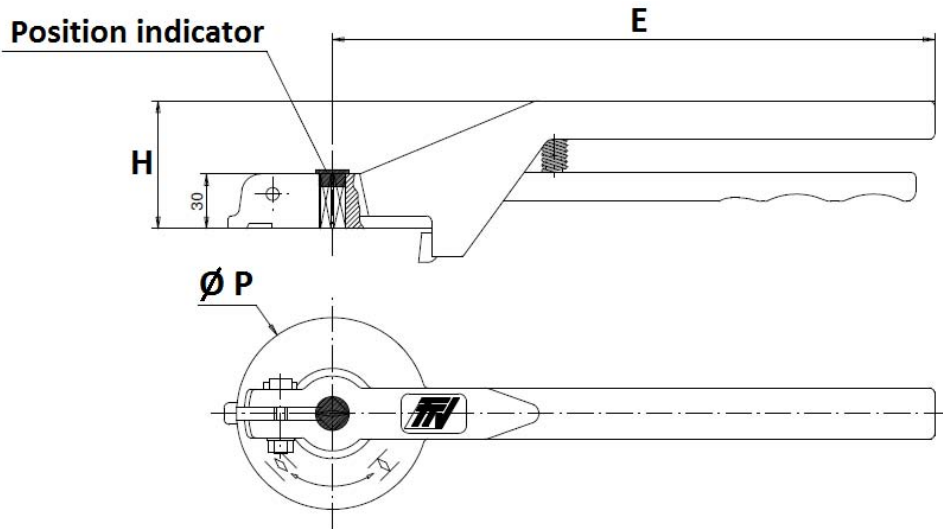

DN	32-100	125-200
E	205	330
H	57	70
Ø P	88	105

DN 250 – 300 :

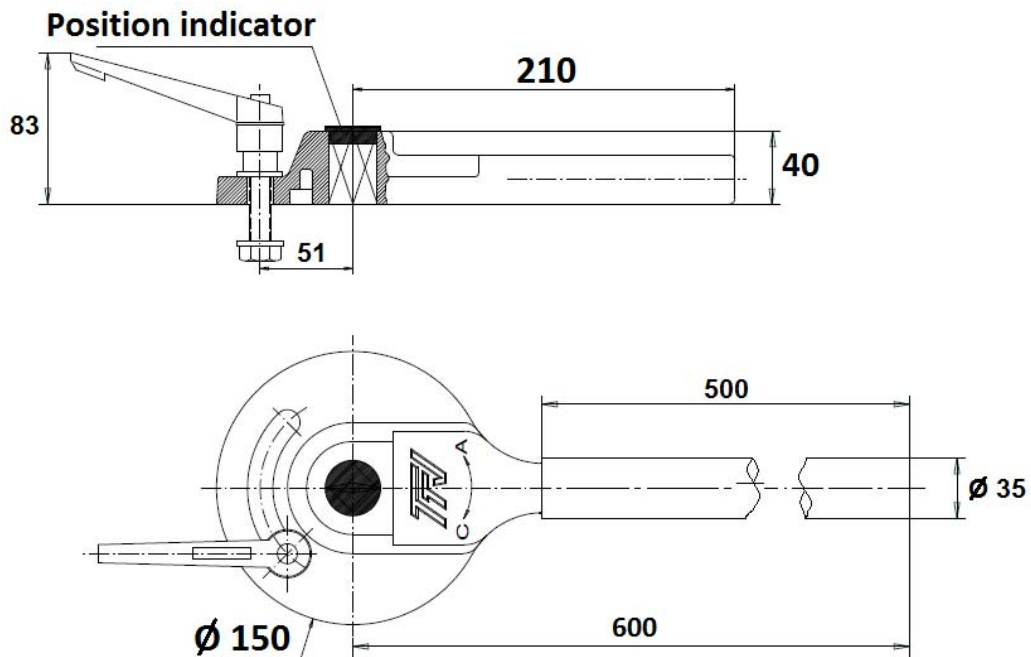

**METAL/METAL WAFER BUTTERFLY VALVE ( NO TIGHTNESS )  
EXCELLENCE RANGE**

**ASTM A351 CF8M STAINLESS STEEL LEVERS SIZE ( in mm ) ( ON REQUEST ) :**

**DN 40 - 100**

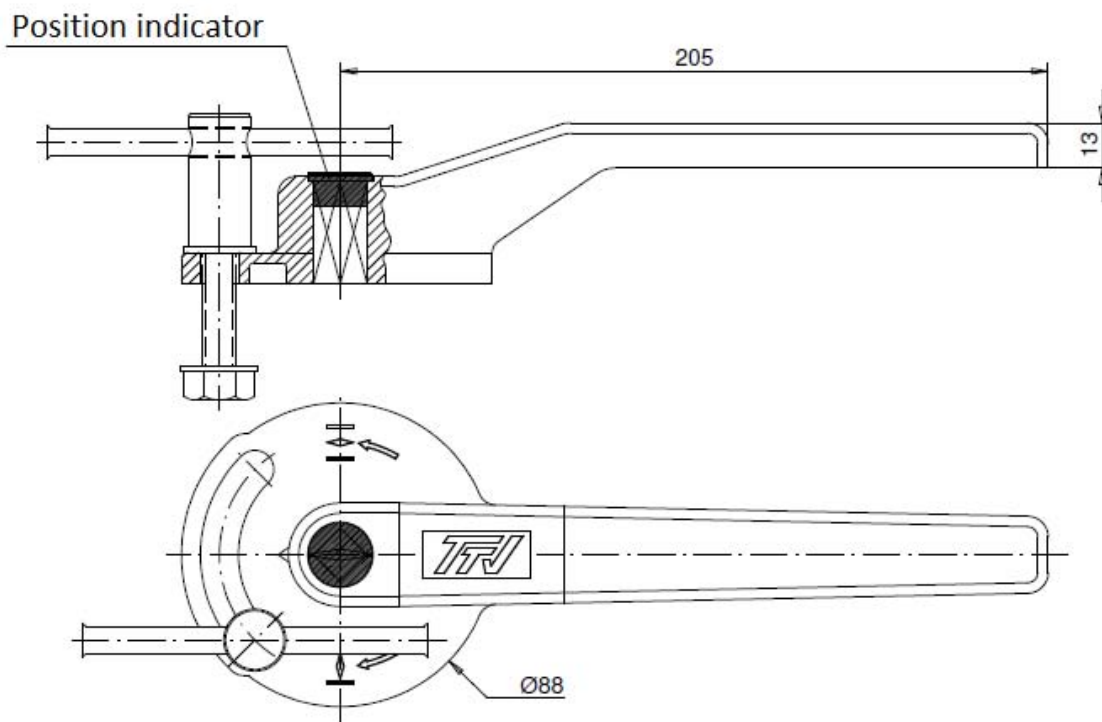

**DN 125 - 200**

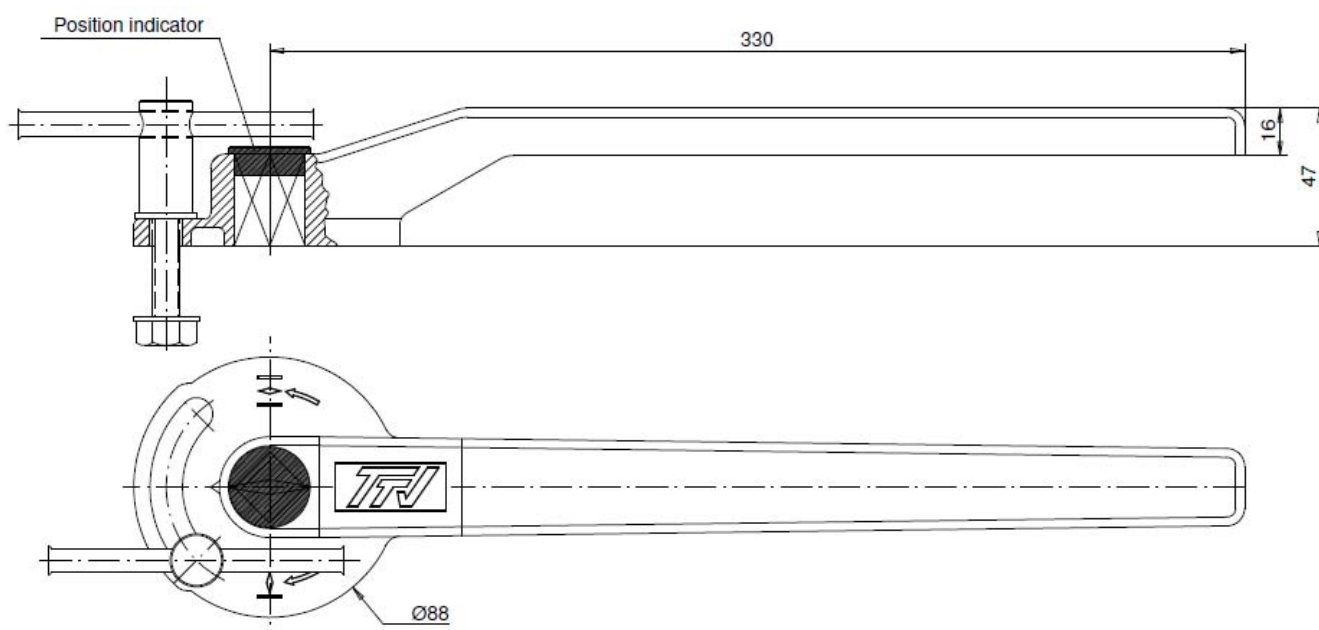



**METAL/METAL WAFER BUTTERFLY VALVE ( NO TIGHTNESS )  
EXCELLENCE RANGE**

SIZE PN10 ( in mm ) :

Valves with gear box DN 40 - 400 :

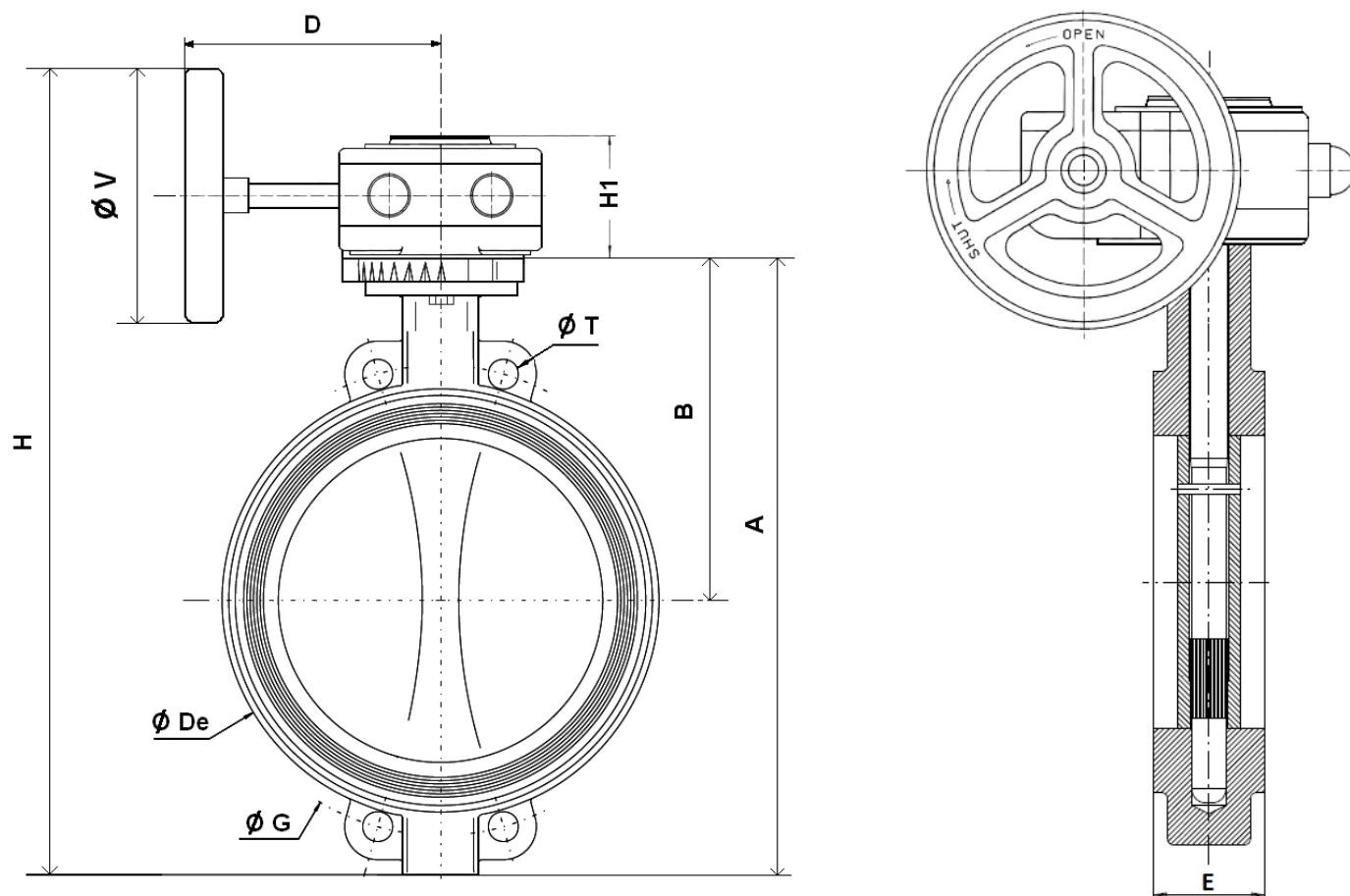

Ref	DN	40	50	65	80	100	125	150	200	250	300	350	400
1111	A	205	228	248	265	298	331	349	430	461	524	570	644
	B	140	156	161	169	187	206	215	255	248	280	300	340
	Ø De	82	102	119	135	155	185	208	270	328	381	437	486
	D	120	120	120	120	120	136	136	136	223	223	345	345
	E	33	43	46	46	52	56	56	60	68	78	78	102
1112	H	304	326	341	364	392	452	477	566	647	709	831	894
	H1	58	58	58	58	58	58	58	58	74	74	98	98
	Ø G	110	125	145	160	180	210	240	295	350	400	460	515
	Ø T	18	18	18	18	18	18	23	23	23	23	23	27
	Ø V	140	140	140	140	140	200	200	200	300	300	400	400
1111	Weight ( Kg )	4.45	5.62	6.62	7.13	8.75	11.9	13.49	21.35	34	44	63.5	84.5
1112	Weight ( Kg )	4.42	6.92	6.24	7.3	8.93	11.97	13.98	20.75	34	44	63.5	84.5

**METAL/METAL WAFER BUTTERFLY VALVE ( NO TIGHTNESS )  
EXCELLENCE RANGE**

SIZE PN10 ( in mm ) :

Valves with gear box DN 450 - 1400 :

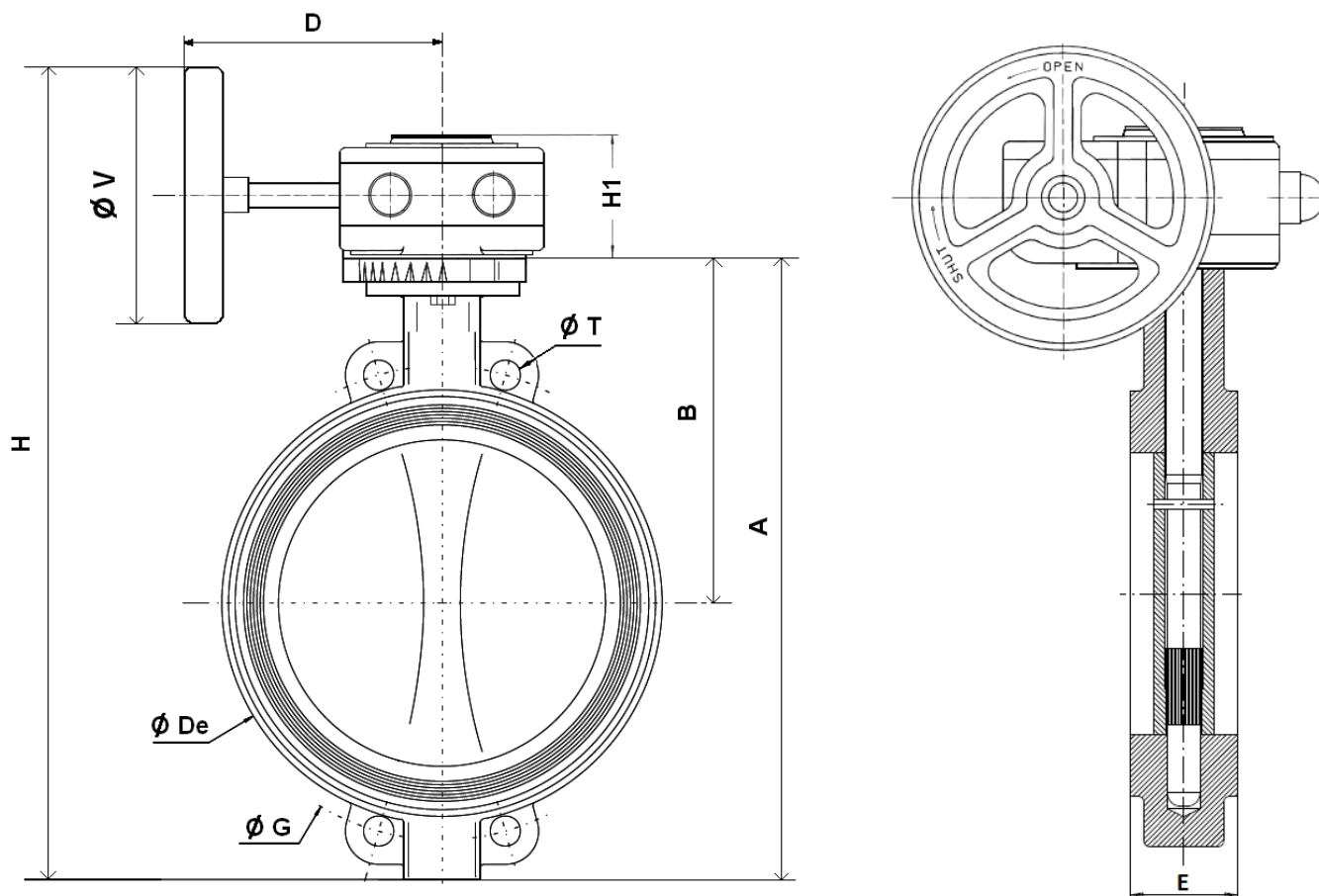

DN	450	500	600	700	750	800	900	1000	1100	1200	1300	1400
A	721	810	950	1085	1135	1233	1310	1442	1565	1706	1895	1975
B	390	440	507	575	600	655	685	754	815	873	1005	1025
Ø De	538	595	695	804	860	911	1010	1124	1225	1330	1460	1530
D	364	386	421	440	440	438	492	492	492	550	605	605
E	114	127	154	165	190	190	203	216	216	254	360	360
H	1083	1171	1376	1409	1459	1657	1688	1820	1943	2178	2260	2429
H1	90	98	122	117	117	117	125	125	125	115	178	178
Ø G	565	620	725	840	900	950	1050	1160	1270	1380	-	1590
Ø T	M24	M24	M27	M27	M30	M30	M30	M33	M33	M36	-	M39
Ø V	600	600	700	500	500	700	600	600	600	800	700	700
Weight ( Kg )	135.8	179.8	278.3	376	430	480.3	710.8	909.8	1124.8	1391.5	2243	2552

**METAL/METAL WAFER BUTTERFLY VALVE ( NO TIGHTNESS )  
EXCELLENCE RANGE**

SIZE PN10 ( in mm ) :

Valves with chain gear box :

Chain size :

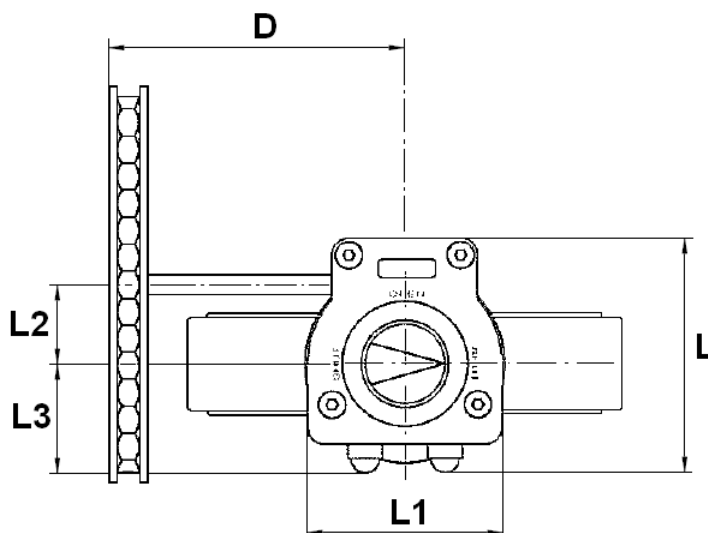
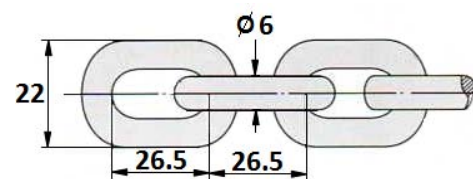
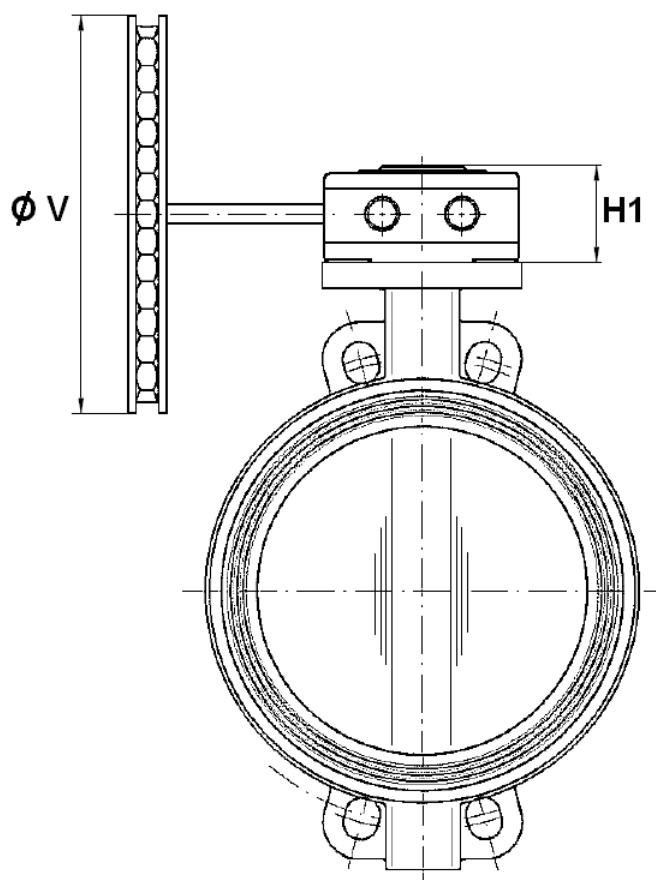

Ref	DN	40	50	65	80	100	125	150	200	250	300	350	400	450	500
1111	D	120	120	120	120	120	126	126	126	214	214	331	331	350	365
	H1	58	58	58	58	58	58	58	58	74	74	98	98	90	98
	L	128	128	128	128	128	128	128	128	175	175	224	224	232	267
	L1	100	100	100	100	100	100	100	100	142	142	185	185	204	227
1112	L2	50	50	50	50	50	50	50	50	61	61	80	80	86	104.5
	L3	56	56	56	56	56	56	56	56	80	80	98	98	100	110
	ø V	160	160	160	160	160	210	210	210	300	300	400	400	500	500
1111	Weight ( Kg )	5.45	6.62	7.62	8.13	9.75	12.9	14.49	22.35	36.8	46.8	68.3	89.3	143.2	186.7
1112	Weight ( Kg )	5.42	6.92	7.24	8.3	9.93	12.97	14.98	21.75	36.8	46.8	68.3	89.3	143.2	186.7

**METAL/METAL WAFER BUTTERFLY VALVE ( NO TIGHTNESS )  
 EXCELLENCE RANGE**

**GEARBOX SPECIFICATIONS :**

DN	32/50	65	80/100	125/150	200	250	300	350
Ref.	1197050	1197065	1197100	1197150	1197200	1197250	1197300	1197350
Ratio factor	37 : 1	37 : 1	37 : 1	37 : 1	37 : 1	36 : 1	36 : 1	50 : 1
Number of cycles for opening or closing	9.25	9.25	9.25	9.25	9.25	9	9	12.5
Input torque ( Nm )	12.5	12.5	12.5	12.5	12.5	23	23	50
Output torque ( Nm )	300	300	300	300	300	675	675	1310

DN	400	450	500	600	700	800	900	1000
Ref.	1197400	1197451	1197501	1197601	1197700	1197800	-	-
Ratio factor	50 : 1	38 : 1	55 : 1	52 : 1	208 : 1	208 : 1	312 : 1	312 : 1
Number of cycles for opening or closing	12.5	9.5	13.75	13	52	52	78	78
Input torque ( Nm )	50	86	96	160	65	65	80	80
Output torque ( Nm )	1310	1620	2640	4160	6800	6800	12500	12500

DN	1200	1300	1400
Ratio factor	702 : 1	720 : 1	720 : 1
Number of cycles for opening or closing	175.5	180	180
Input torque ( Nm )	50	91	91
Output torque ( Nm )	17000	32000	32000



**METAL/METAL WAFER BUTTERFLY VALVE ( NO TIGHTNESS )  
EXCELLENCE RANGE**

**NECK AND DISC SIZE ( in mm ) :**

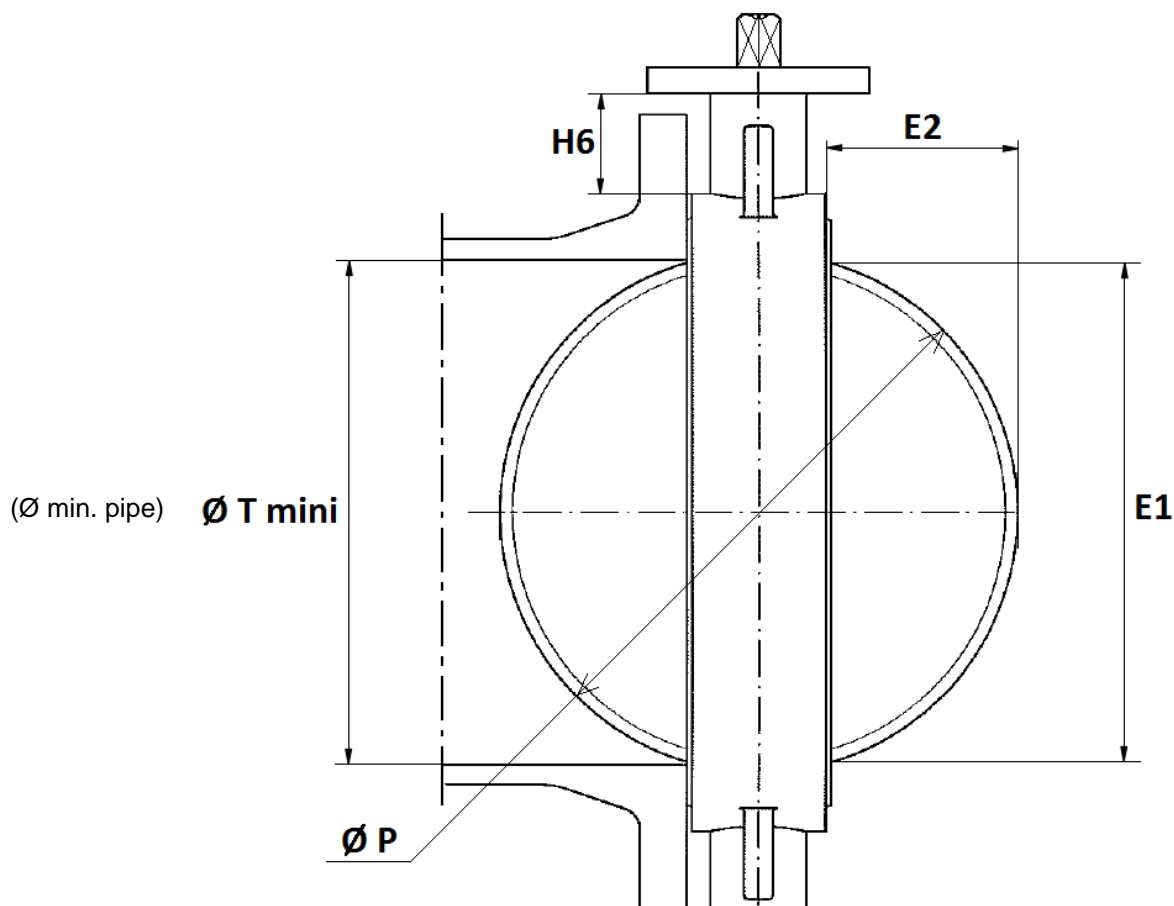

DN	32/40	50	65	80	100	125	150	200	250	300	350	400	450	500	600
E1	23	24.5	46	65	85	109	136	188	238	289	331	385	424	479	575
E2	3.5	3.5	9.5	17	24	33.5	45.5	69	90	110.5	131	148	162.5	184	221
H6	76	82	80	80	88	93	89	99	71	76	69	80	96	119	127
Ø T mini	26	27.5	49	68	88	112	139	191	241	292	334	388	427	482	578
Ø P	40	50	65	80	100	123	147	198	248	299	340	398	439	495	596

DN	700	750	800	900	1000	1100	1200	1300	1400
E1	680	721	777	850	957	1052	1146	1261	1368
E2	267.5	278	305	335.5	382.5	429	460	475.5	527.5
H6	148	140	170	150	162	175	176	240	228
Ø T mini	683	724	780	853	960	1055	1149	1264	1371
Ø P	700	746	800	874	981	1074	1174	1311	1415

**METAL/METAL WAFER BUTTERFLY VALVE ( NO TIGHTNESS )  
EXCELLENCE RANGE**

SIZE ( in mm ) :

Square lever for special key ( 30x30 mm ) :

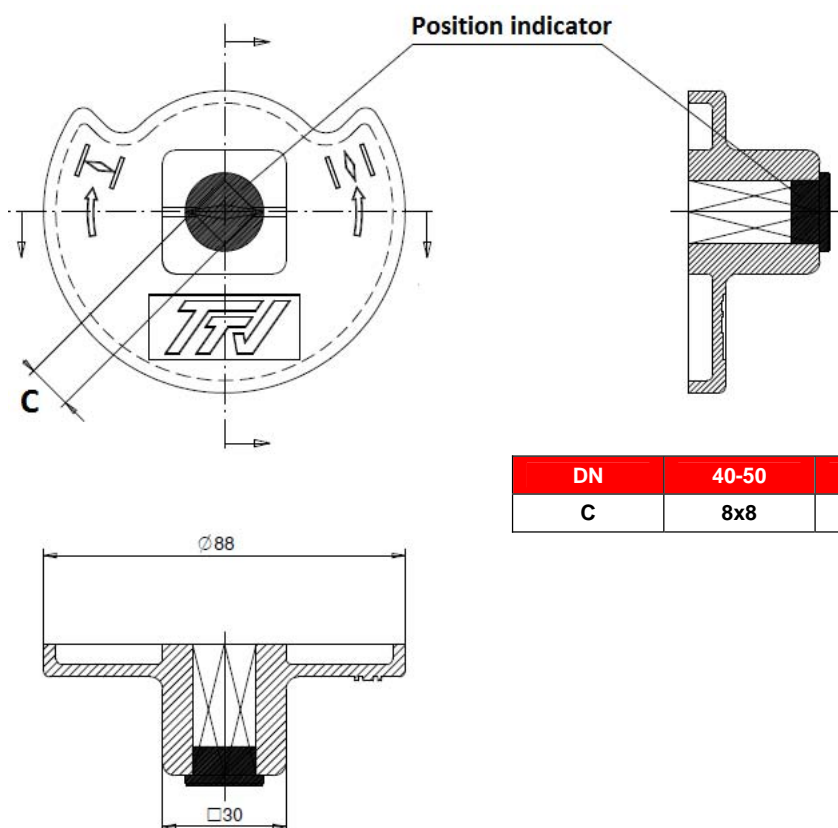

DN	40-50	65	80-100	125-150	200
C	8x8	9x9	11x11	14x14	17x17

**METAL/METAL WAFER BUTTERFLY VALVE ( NO TIGHTNESS )  
EXCELLENCE RANGE**

**ISO MOUNTING PAD AND STEM SIZE DN 40 - 400 ( in mm ) :**

**DN 40 – 200**

**DN250 - 400**

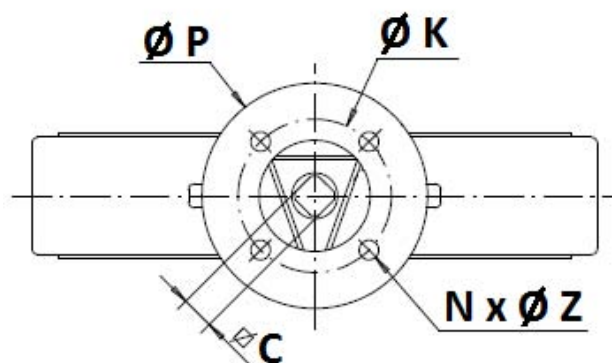
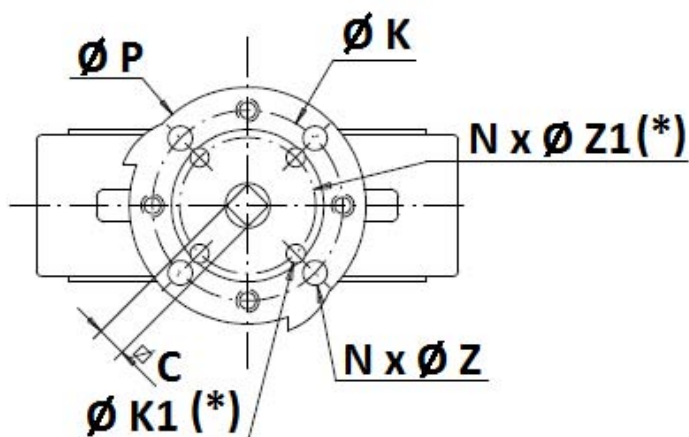
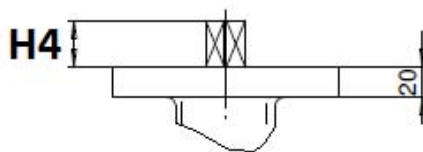
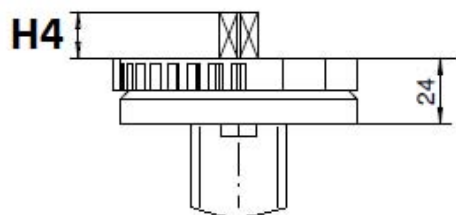

(\*) : Only from DN32 to DN100

DN	40	50	65	80	100	125	150	200	250	300	350	400
H4	14	14	16	16	20	20	20	24	24	24	29	29
C	8	8	9	11	11	14	14	17	19	22	22	27
Ø K	70	70	70	70	70	70	70	70	102	102	140	140
ISO	F07	F07	F07	F07	F07	F07	F07	F07	F10	F10	F14	F14
N x Ø Z	4 x 9	4 x 9	4 x 9	4 x 9	4 x 9	4 x 9	4 x 9	4 x 9	4 x 11	4 x 11	4 x 18	4 x 18
Ø K1	50	50	50	50	50	-	-	-	-	-	-	-
ISO 1	F05	F05	F05	F05	F05	-	-	-	-	-	-	-
N x Ø Z1	4 x 7	4 x 7	4 x 7	4 x 7	4 x 7	-	-	-	-	-	-	-

**METAL/METAL WAFER BUTTERFLY VALVE ( NO TIGHTNESS )  
EXCELLENCE RANGE**

ISO MOUNTING PAD AND STEM SIZE DN450-1400 ( in mm ) :

**DN 450 - 1400**

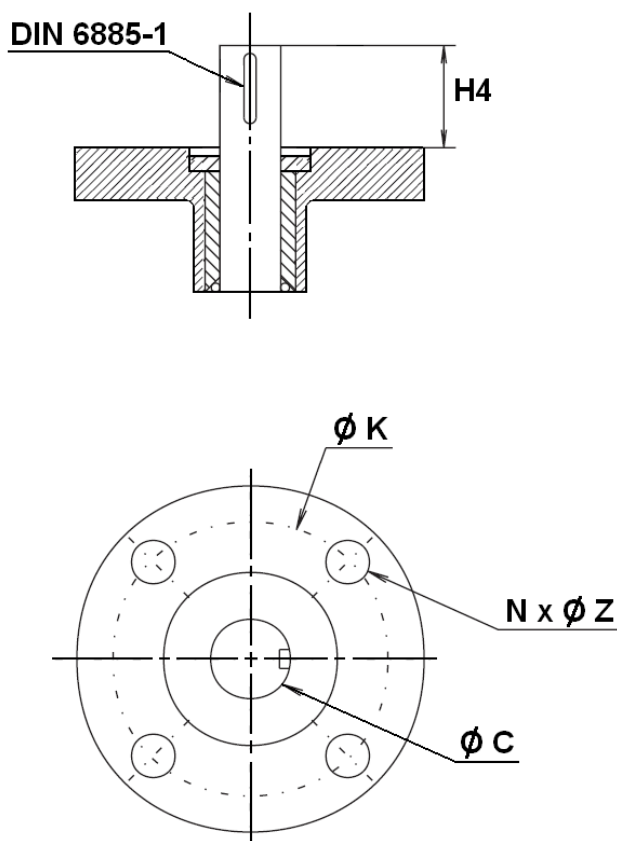

DN	450	500	600	700	750	800	900	1000	1100	1200	1300	1400
H4	80	80	90	90	110	110	110	110	110	110	120	120
Ø C	50	50	60	60	65	65	80	80	80	100	120	120
Ø K	140	140	165	254	254	254	254	254	254	254	298	298
ISO	F14	F14	F16	F25	F25	F25	F25	F25	F25	F25	F30	F30
N x Ø Z	4 x 18	4 x 18	4 x 22	8 x 18	8 x 18	8 x 18	8 x 18	8 x 18	8 x 18	8 x 18	8 x 22	8 x 22

**METAL/METAL WAFER BUTTERFLY VALVE ( NO TIGHTNESS )  
EXCELLENCE RANGE**

**STANDARDS :**

Fabrication according to ISO 9001:2008

Designing according to ISO 10631

DIRECTIVE 97/23/CE : CE N° 0038  
Risk Category III module H

**Body tests** according to ISO 5208, range A

Between flanges according to EN 1092-1 PN10/16

ISO 5211 mounting pad

Length according to ISO 5752 short series 20, EN 558 series 20 ( NF 29305 ), BS 5155 Wafer short/medium, DIN 3202 part 3, series K1

ATEX Group II Category 2 G/2D Zone 1 & 21 Zone 2 & 22 ( optional marking )

OTAN agreement ( N° 286B )

**ADVICE :** Our opinion and our advice are not guaranteed and SFERACO shall not be liable for the consequences of damages.  
The customer must check the right choice of the products with the real service conditions.

**METAL/METAL WAFER BUTTERFLY VALVE ( NO TIGHTNESS )  
EXCELLENCE RANGE****INSTALLATION INSTRUCTIONS****GENERAL GUIDELINES :**

Ensure that the valves to be used are appropriate for the conditions of the installation (type of fluid, pressure and temperature).

Be sure to have enough valves to be able to isolate the sections of piping as well as the appropriate equipment for maintenance and repair.

Ensure that the valves to be installed are of correct strength to be able to support the capacity of their usage.

**Installation of all circuits should ensure that their function can be automatically tested on a regular basis (at least two times a year).**

**INSTALLATION INSTRUCTIONS :**

**Before installing the valves, clean and remove any objects from the pipes** (in particular bits of sealing and metal) which could obstruct and block the valves.

**Ensure that both connecting pipes either side of the valve (upstream and downstream) are aligned (if they're not, the valves may not work correctly).**

**Make sure that the two sections of the pipe (upstream and downstream) match, the valve unit will not absorb any gaps. Any distortions in the pipes may affect the tightness of the connection, the working of the valve and can even cause a rupture.** To be sure, place the kit in position to ensure the assembling will work.

**If sections of piping do not have their final support in place, they should be temporarily fixed. This is to avoid unnecessary strain on the valve.**

Tighten the bolts in cross.

The disc must move easily inside the pipe.

Valves must be opened during cleaning operation.

Tests must be done with a cleaned pipe.

Tests must be done with opened valve. Test pressure must not be higher than the valve specification according to EN 12266-1.

Then open slowly the valve.

**Do not mount butterfly valves with stainless steel pressed collars and turning flanges without strias.**

**And not on flat face flanges without strias ( example : painted cast iron fittings )**

**MAINTENANCE :**

We recommend to operate fully the valve 1 to 2 times per year.

During maintenance operation, ensure that the pipe isn't under pressure, that there's no fluid in the pipe and that the valve is isolated. If there's a fluid in the pipe, evacuate it. Ensure that there are no risks due to the temperature or the fluid ( like acids ). If the fluid is corrosive, inert the installation before maintenance operation.