

**WAFER BUTTERFLY VALVE EXCELLENCE RANGE  
STAINLESS STEEL BODY AND DISC WITH EPDM SEAT**

**armat**  
spol. s r.o.  
MADE OF STAINLESS...



**Lloyd's Register**

PED 97/23/CE



- Size :** DN 32 to 600 mm  
**Ends :** Between flanges PN10/16 and Class 150 (PN20)  
**Min Temperature :** - 10°C  
**Max Temperature :** + 110°C  
**Max Pressure :** 16 Bars up to DN300  
**Specifications :** Long neck for isolation  
Stainless steel disc  
Full crossing stem  
EPDM elastic ring  
ISO 5211 mounting pad

**Materials :** ASTM A351 CF8M body

\*the installation defects and wear defects are not covered by the guarantee

## WAFER BUTTERFLY VALVE EXCELLENCE RANGE STAINLESS STEEL BODY AND DISC WITH EPDM SEAT

### SPECIFICATIONS :

Long neck for isolation  
 ISO 5211 mounting pad  
 Wafer type  
 Between flanges PN10/16 from DN32/40 to 400 and Class 150 (PN20) from DN40 to 400 (over on request )  
 Between flanges PN10 from DN450 to DN 600  
 Full crossing stem  
 Removable EPDM seat  
 Stainless steel disc  
 9 positions lever with locking device up to DN200 , stop in all positions but non lockable from DN250 to 300  
 Stem extension 75 mm length ( option )  
 Square lever 30x30 mm for special key ( option )

### USE :

Cold and hot water, sea water, alcohol, hydroxyd of soda, demineralized water, mercury, alcalins  
 Min and max Temperature Ts : - 10°C to + 110°C  
 Max Pressure Ps : 16 bars up to DN300, 10 bars over (see graph page 4)

### RANGE :

With lever from DN 32 to DN 300  
 IP65 gear box possible ( **Ref. 1197** ) from DN 32 to DN 600  
 IP65 chain gear box ( **Ref. 1194** ) from DN 32 to DN 500  
 On request, stem extension with special length ( **Ref. 98665** )  
 On request, CF8M stainless steel handle and bolting **Ref. 9831250-9831264**

### ENDS :

Between flanges PN10/16 from DN32/40 to 400 and Class 150 (PN20) from DN40 to 400  
 Between flanges PN10 from DN450 to DN 600

### TORQUE VALUES ( in Nm with safety coefficient of 30 % included ) at 16 Bars :

DN	32/40	50	65	80	100	125	150	200	250	300
Torque ( Nm )	9	11	20	29	47	82	130	210	360	475

### TORQUE VALUES ( in Nm with safety coefficient of 30 % included ) at 10 Bars :

DN	350	400	450	500	600
Torque ( Nm )	640	1176	1450	2150	2850

### FLOW COEFFICIENT Kvs ( m<sup>3</sup> / h ) :

DN	32/40	50	65	80	100	125	150	200	250	300	350	400
Kvs ( m <sup>3</sup> /h )	70	109	200	334	551	901	1427	2383	3825	5659	8177	10659

DN	450	500	600
Kvs ( m <sup>3</sup> /h )	12562	16021	22737

**WAFER BUTTERFLY VALVE EXCELLENCE RANGE  
STAINLESS STEEL BODY AND DISC WITH EPDM SEAT**

**HEAD LOSS GRAPH :**

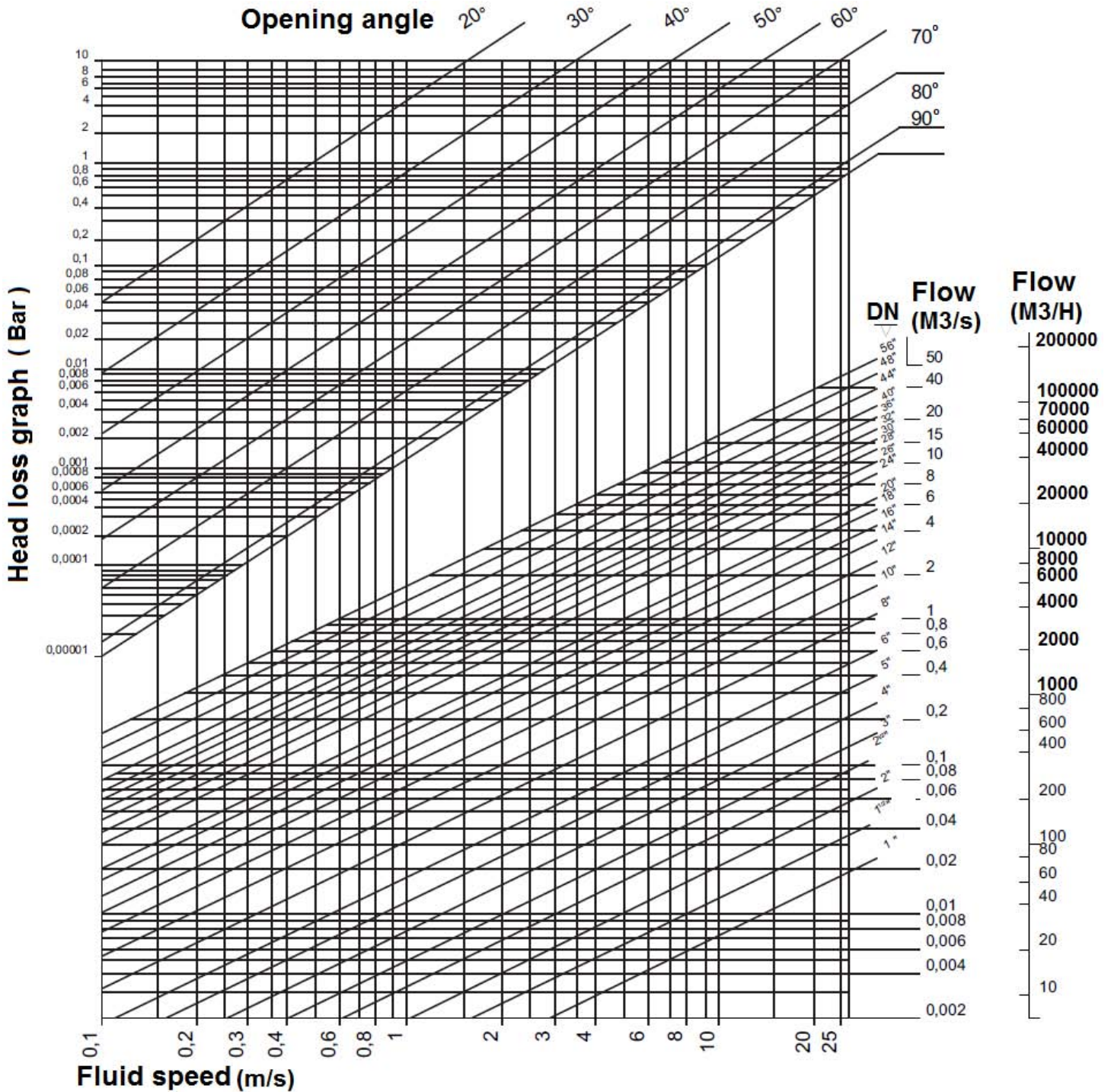

**WAFER BUTTERFLY VALVE EXCELLENCE RANGE  
STAINLESS STEEL BODY AND DISC WITH EPDM SEAT**

PRESSURE / TEMPERATURE GRAPH (STEAM EXCLUDED):

? EPDM seat for Ps 16 BAR DN40-300 :

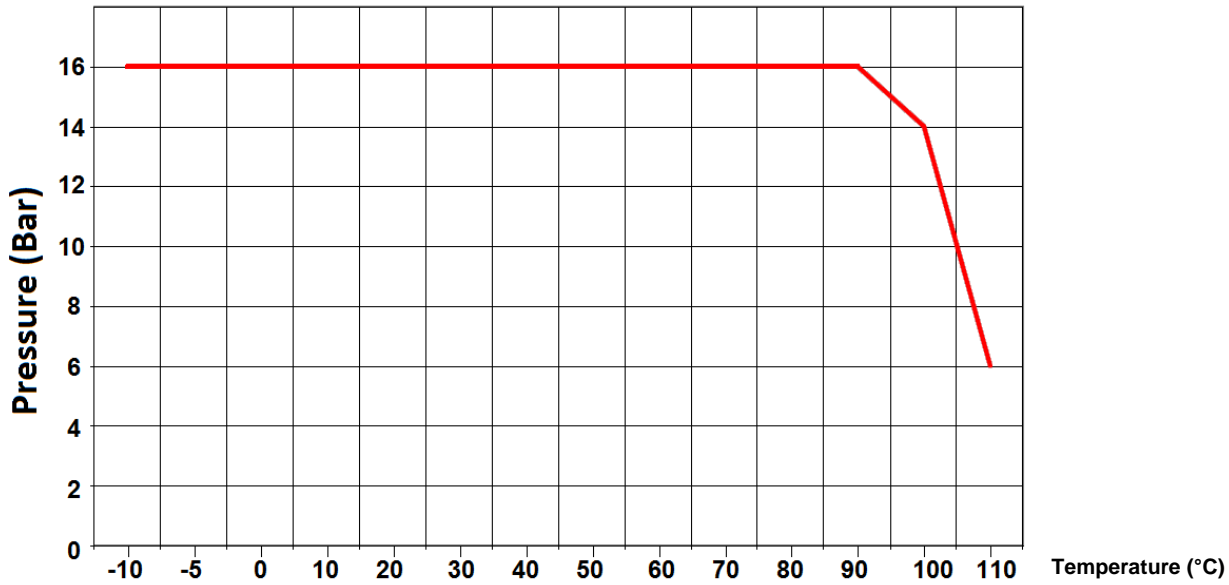

? EPDM seat for Ps 10 BAR DN350-1200 :

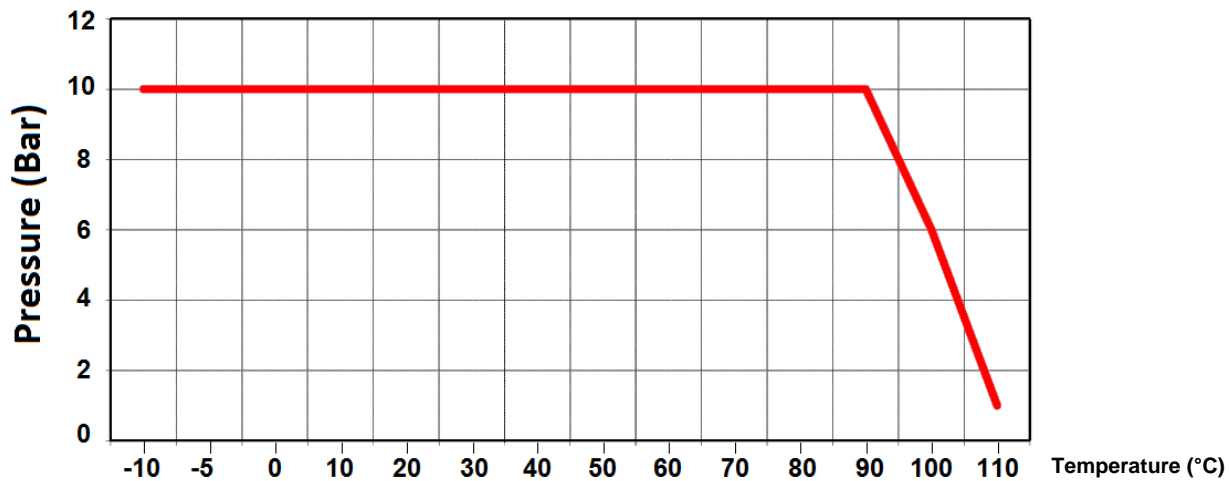

**WAFER BUTTERFLY VALVE EXCELLENCE RANGE  
STAINLESS STEEL BODY AND DISC WITH EPDM SEAT**

MATERIALS DN 32 - 200 :

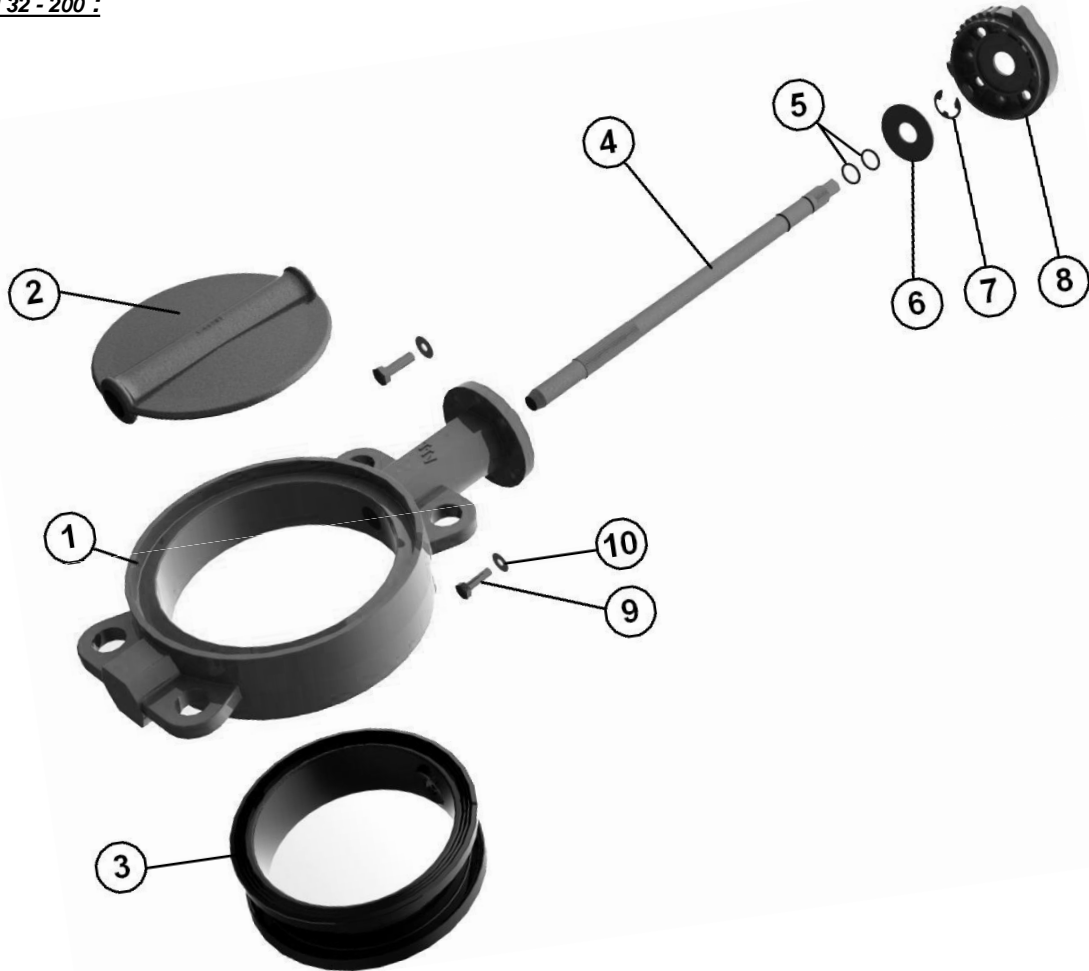

Item	Designation	Materials
1	Body	ASTM A351 CF8M
2	Disc	ASTM A351 C8FM
3	Seat	EPDM
4	Stem	SS 316
5	O ring	NBR
6	Ring	SS 316
7	Circlips	SS 316
8	Plate	ASTM A351 CF8M
9	Plate screw	A4
10	Washer	SS 316
	Lever	Aluminium ADC10 with epoxy painting 50μ thickness

**WAFER BUTTERFLY VALVE EXCELLENCE RANGE  
STAINLESS STEEL BODY AND DISC WITH EPDM SEAT**

MATERIALS DN 250 - 400 :



Item	Designation	Materials
1	Body	ASTM A351 CF8M
2	Disc	ASTM A351 C8FM
3	Seat	EPDM
4	Stem	SS 316
5	O ring	NBR
6	Circlips	SS 316
7	Ring	SS 316
8	Spring	SS 316
Lever ( up to DN300 )		Ductile iron EN GJS-500-7 with epoxy painting 50μ thickness

**WAFER BUTTERFLY VALVE EXCELLENCE RANGE  
STAINLESS STEEL BODY AND DISC WITH EPDM SEAT**

MATERIALS DN 450 - 600 :

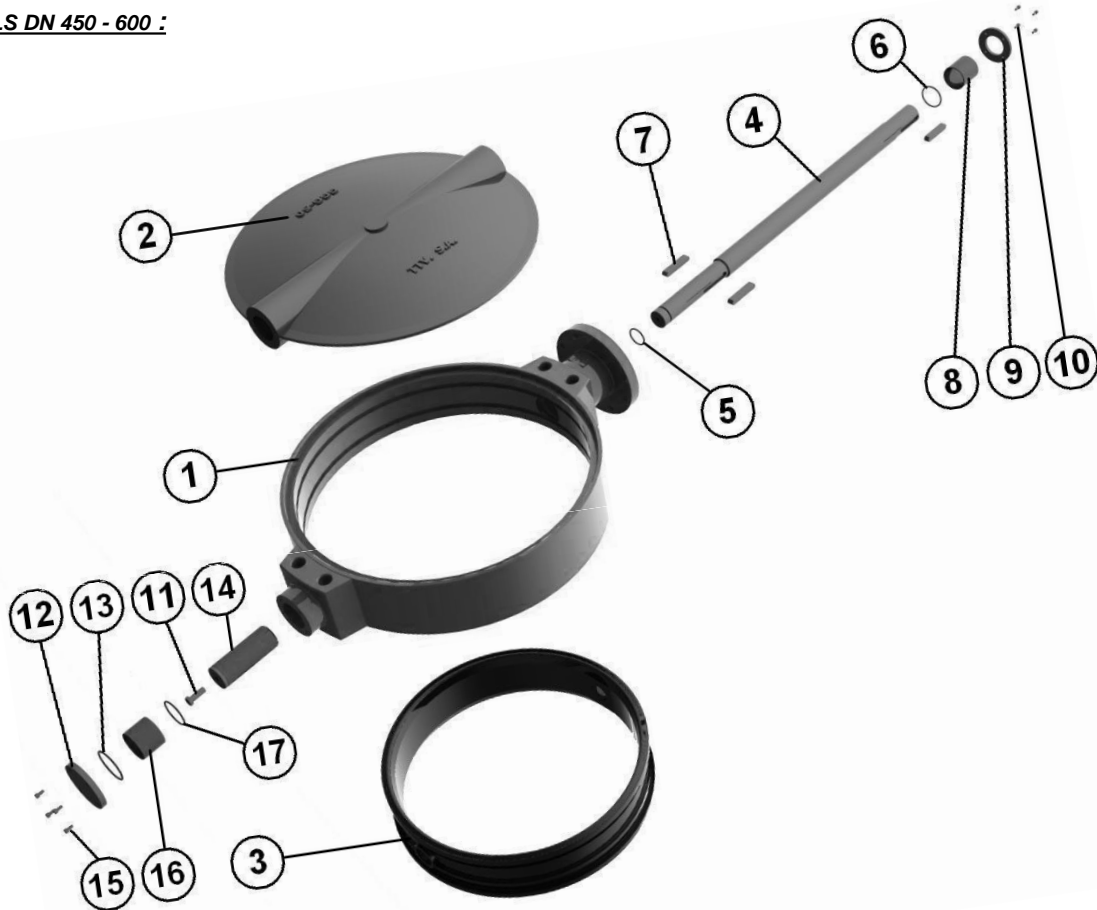

Item	Designation	Materials
1	Body	ASTM A351 CF8M
2	Disc	ASTM A351 C8FM
3	Seat	EPDM
4	Stem	SS 316
5	O ring	NBR
6	O ring	NBR
7	Pin	SS 316
8	Bushing	BRONZE
9	Ring	SS 316
10	Screw	A4
11	Screw	A4
12	Cap	SS 316
13	O ring	NBR
14	Bushing	SS 316
15	Screw	A4
16	Bushing	BRONZE
17	O ring	NBR

**WAFER BUTTERFLY VALVE EXCELLENCE RANGE  
STAINLESS STEEL BODY AND DISC WITH EPDM SEAT**

GEARBOX MATERIALS REF. 1197 :

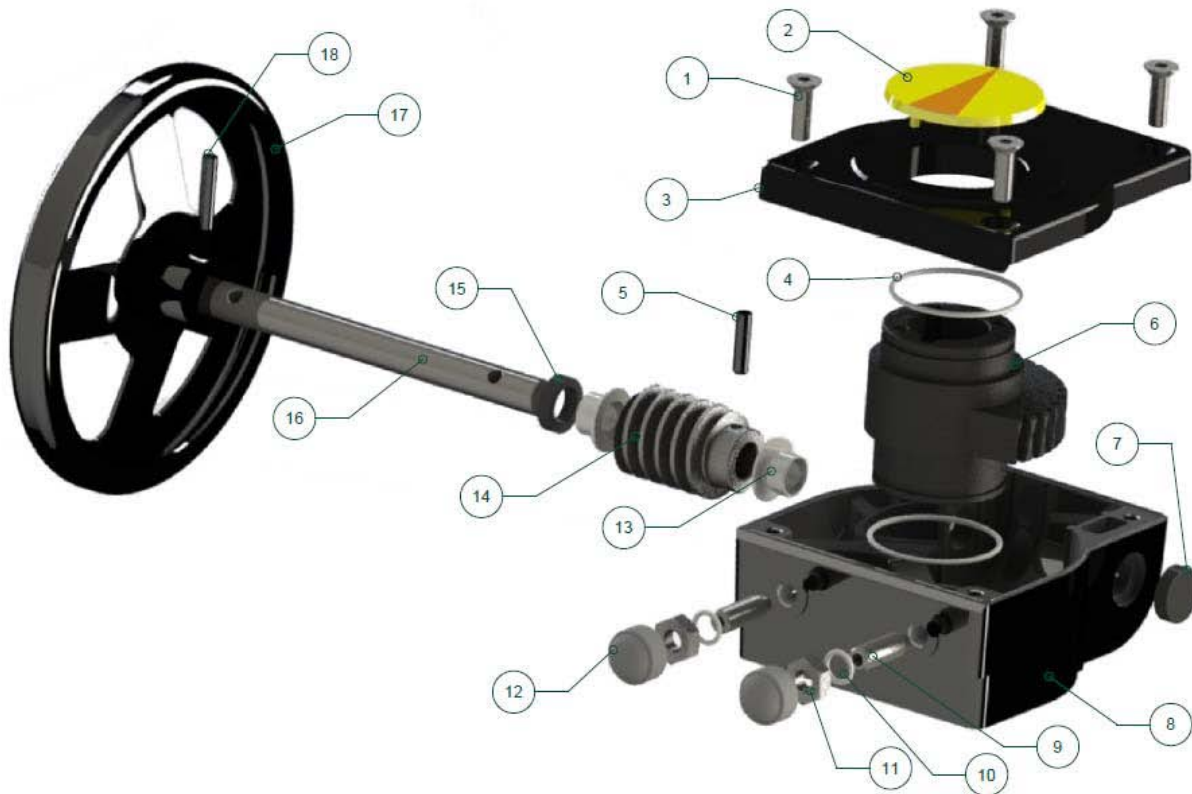

Item	Designation	Materials Ref. 1197
1	Screw	SS 304
2	Pointer	Polypropylene
3	Bonnet	Aluminium
4	O ring	NBR
5	Pin	Carbon steel
6	Quadrant	Ductile iron EN GJS-400-15
7	Gasket	NBR
8	Body	Aluminium
9	Adjusting bolt	Carbon steel
10	Washer	Galvanized steel
11	Nut	Galvanized steel
12	Cap	NBR 70
13	Bushing	Bronze
14	Worm	Carbon steel 45
15	Gasket	NBR
16	Stem	Carbon steel 45
17	Handwheel	Carbon steel
18	Pin	Carbon steel



**WAFER BUTTERFLY VALVE EXCELLENCE RANGE  
STAINLESS STEEL BODY AND DISC WITH EPDM SEAT**

SIZE PN10 ( in mm ) :

Valves DN 32 - 200 :

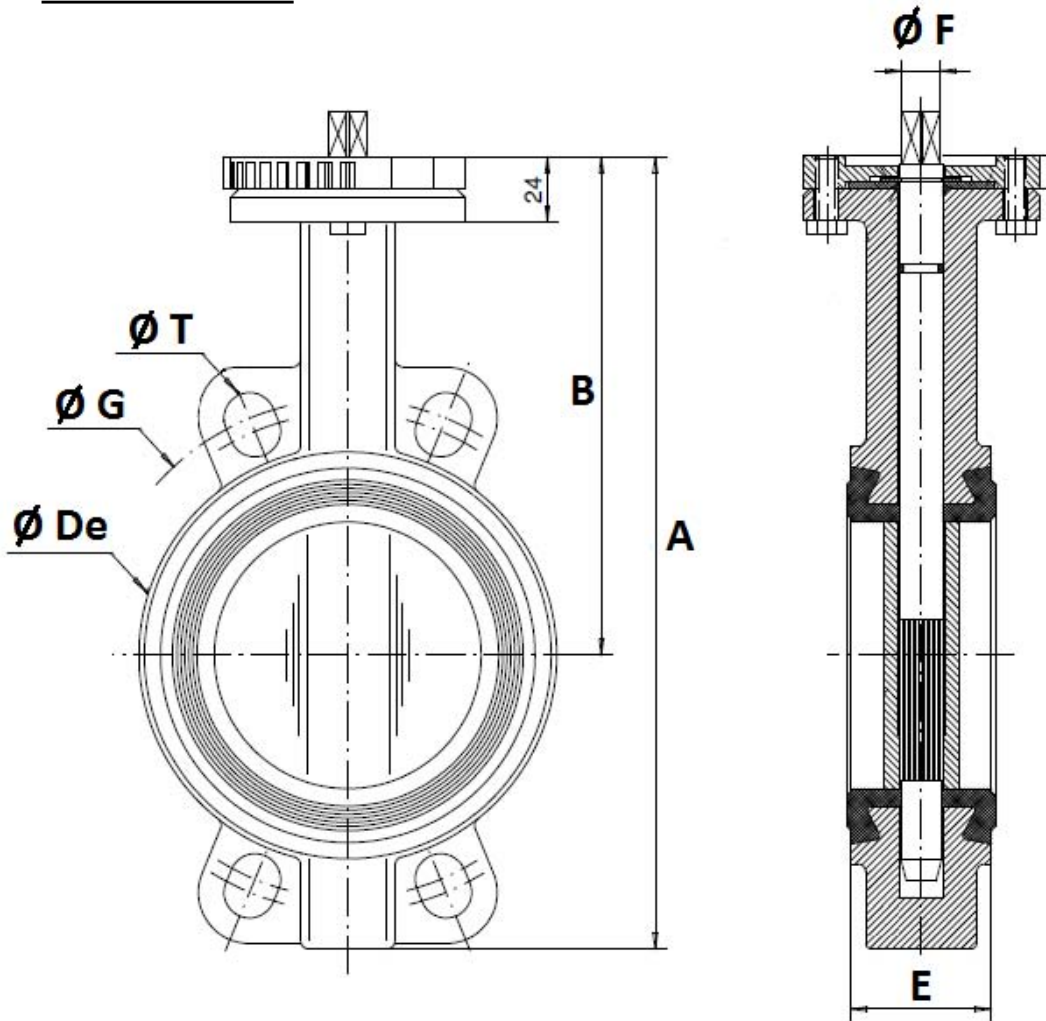

DN	32/40	50	65	80	100	125	150	200
A	206	228	248	265	298	331	349	430
B	140	156	161	169	187	206	215	255
Ø De	82	102	119	135	155	185	208	270
E	33	43	46	46	52	56	56	60
Ø F	9.5	9.5	12	14	14	17	17	21
Ø G	110	125	145	160	180	210	240	295
Ø T	18	18	18	18	18	18	23	23
Weight (Kg)	2.46	3.66	4.4	4.6	6	7.6	9.2	14.7

**WAFER BUTTERFLY VALVE EXCELLENCE RANGE  
STAINLESS STEEL BODY AND DISC WITH EPDM SEAT**

SIZE PN10 ( in mm ) :

Valves DN 250 -400 :

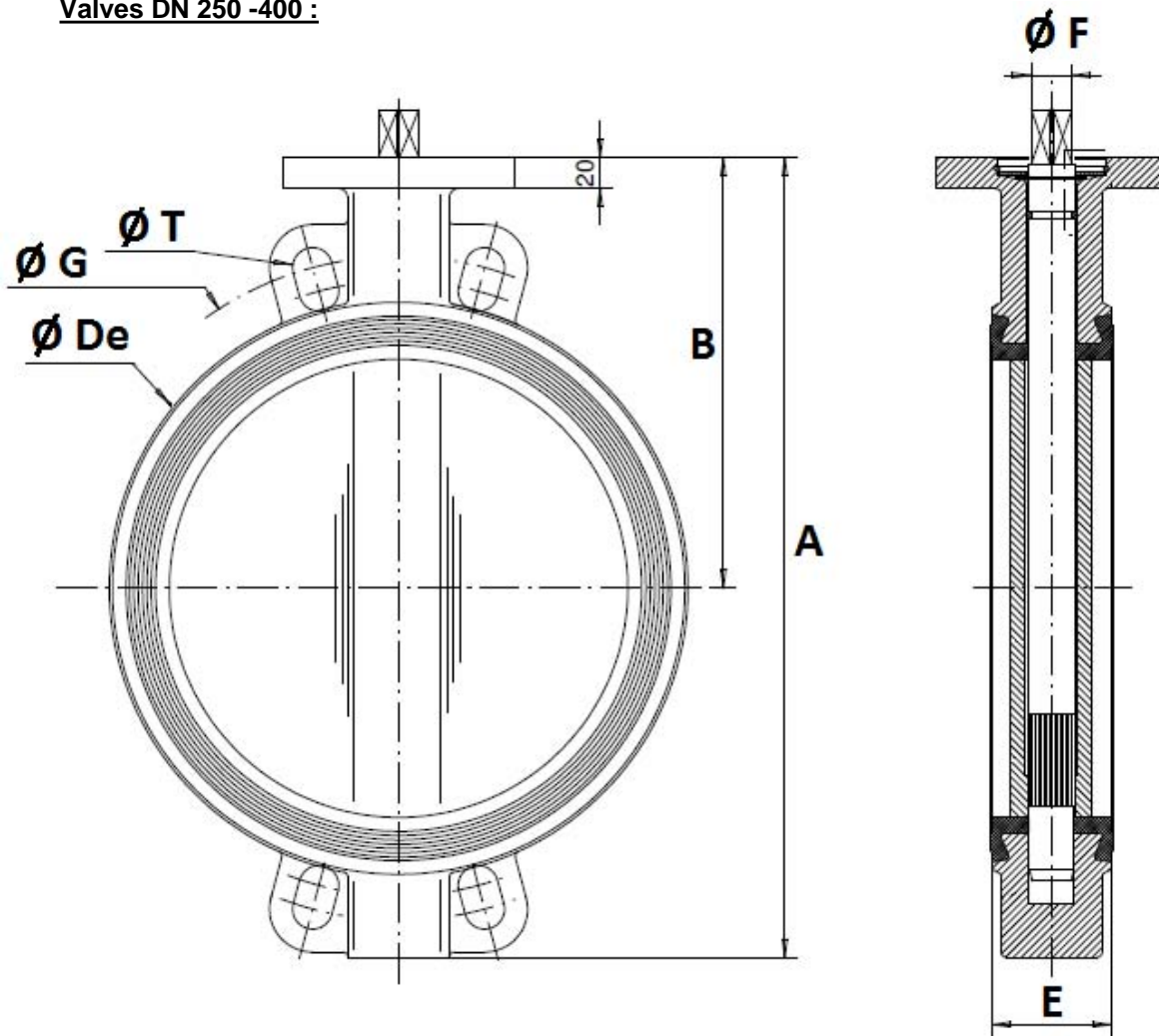

DN	250	300	350	400
A	461	524	570	644
B	248	280	300	340
$\varnothing De$	328	381	437	486
E	68	78	78	102
$\varnothing F$	23	26.5	26.5	33
$\varnothing G$	350	400	460	515
$\varnothing T$	23	23	23	27
Weight (Kg)	24.7	33	39	52

**WAFER BUTTERFLY VALVE EXCELLENCE RANGE  
STAINLESS STEEL BODY AND DISC WITH EPDM SEAT**

STANDARD LEVERS SIZE ( in mm ) :

**DN 32 – 200 :**

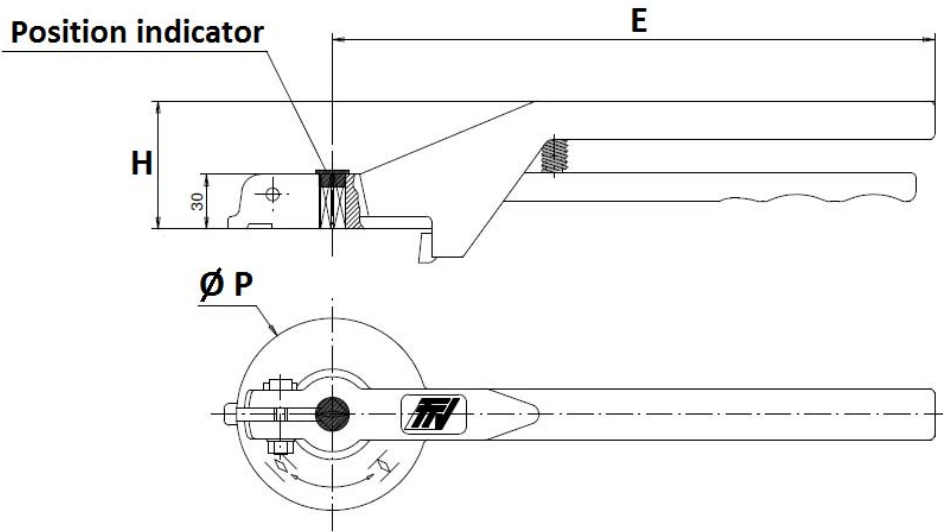

DN	32-100	125-200
E	205	330
H	57	70
Ø P	88	105

**DN 250 – 300 :**

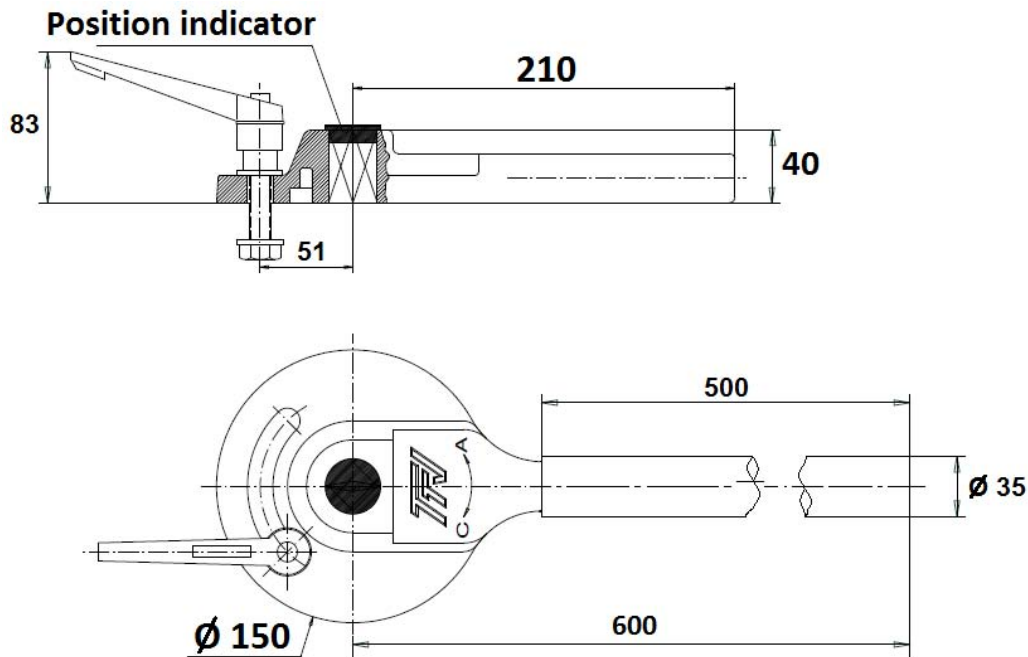

**WAFER BUTTERFLY VALVE EXCELLENCE RANGE  
STAINLESS STEEL BODY AND DISC WITH EPDM SEAT**

**ASTM A351 CF8M STAINLESS STEEL LEVERS SIZE ( in mm ) ( ON REQUEST ) :**

**DN 40 - 100**

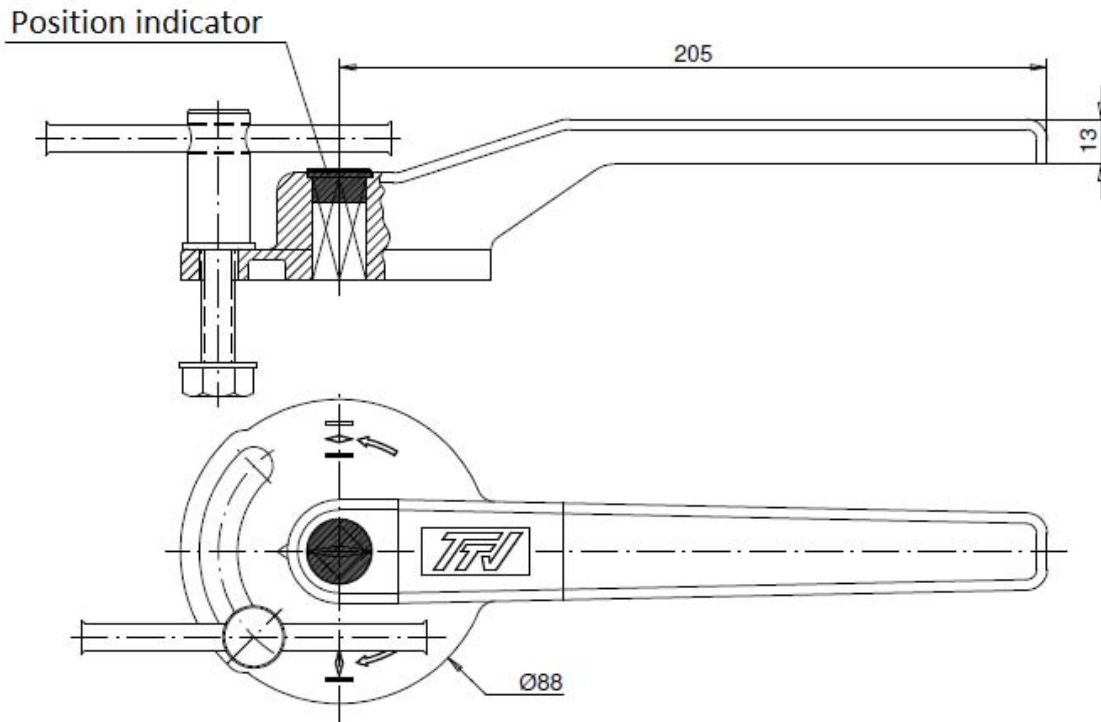

**DN 125 - 200**

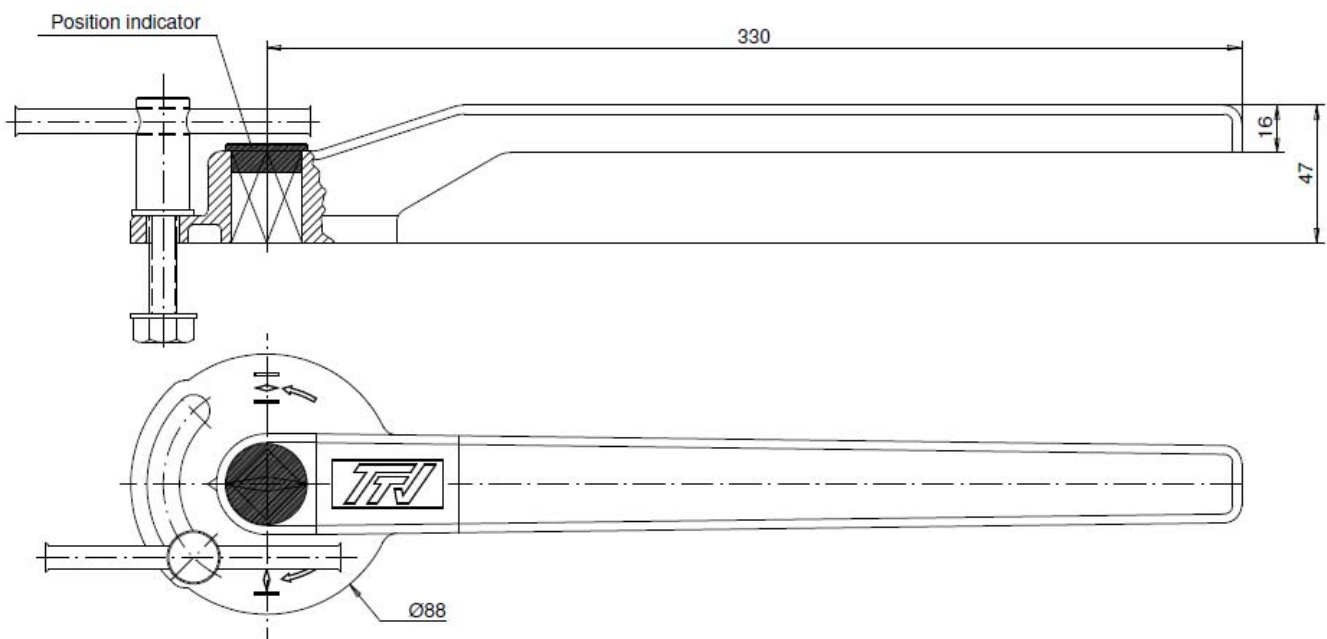

**WAFER BUTTERFLY VALVE EXCELLENCE RANGE  
STAINLESS STEEL BODY AND DISC WITH EPDM SEAT**

SIZE PN10 ( in mm ) :

Valves DN 450 - 600 :

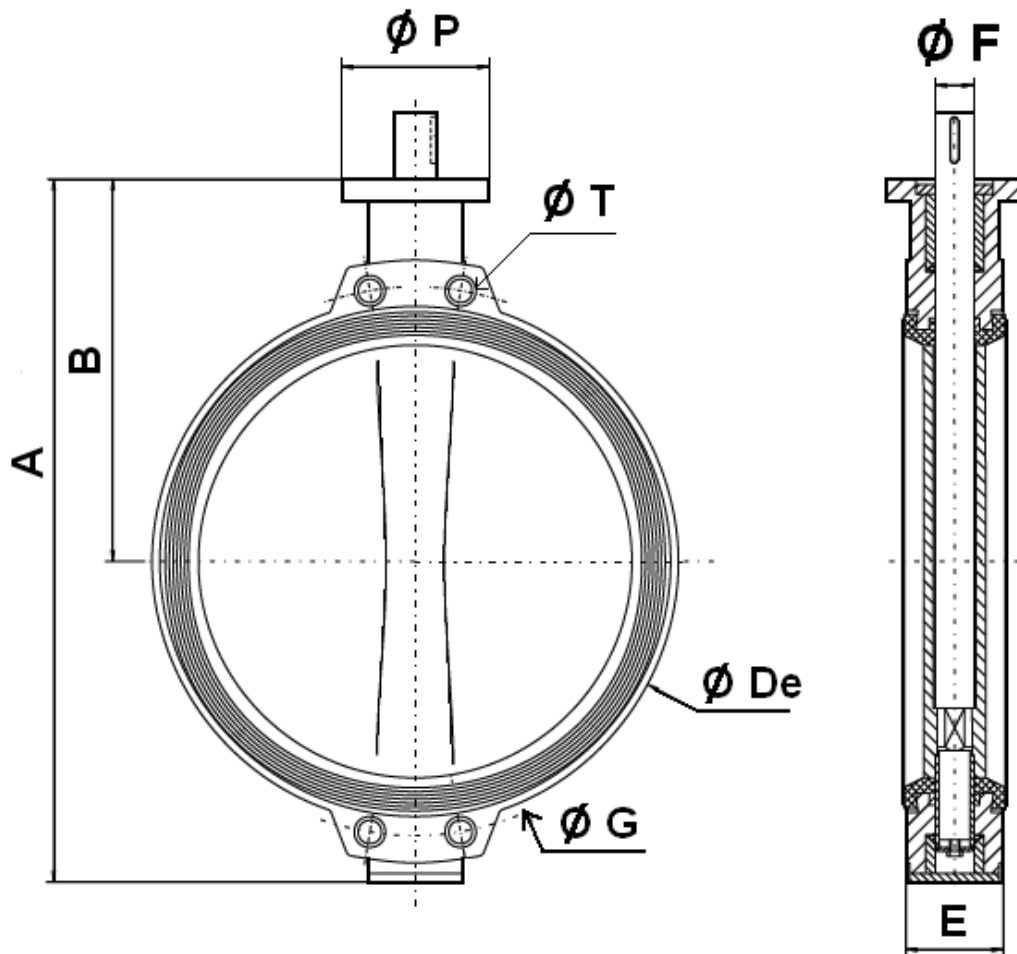

DN	450	500	600
A	738	822	965
B	394	440	507
Ø De	538	595	695
E	114	127	154
Ø F	50	50	60
Ø G	565	620	725
Ø P	175	175	250
Ø T	M24	M24	M27
Weight (Kg)	87	117	177

**WAFER BUTTERFLY VALVE EXCELLENCE RANGE  
STAINLESS STEEL BODY AND DISC WITH EPDM SEAT**

SIZE PN10 ( in mm ) :

Valves with gearbox DN 32 - 400 :

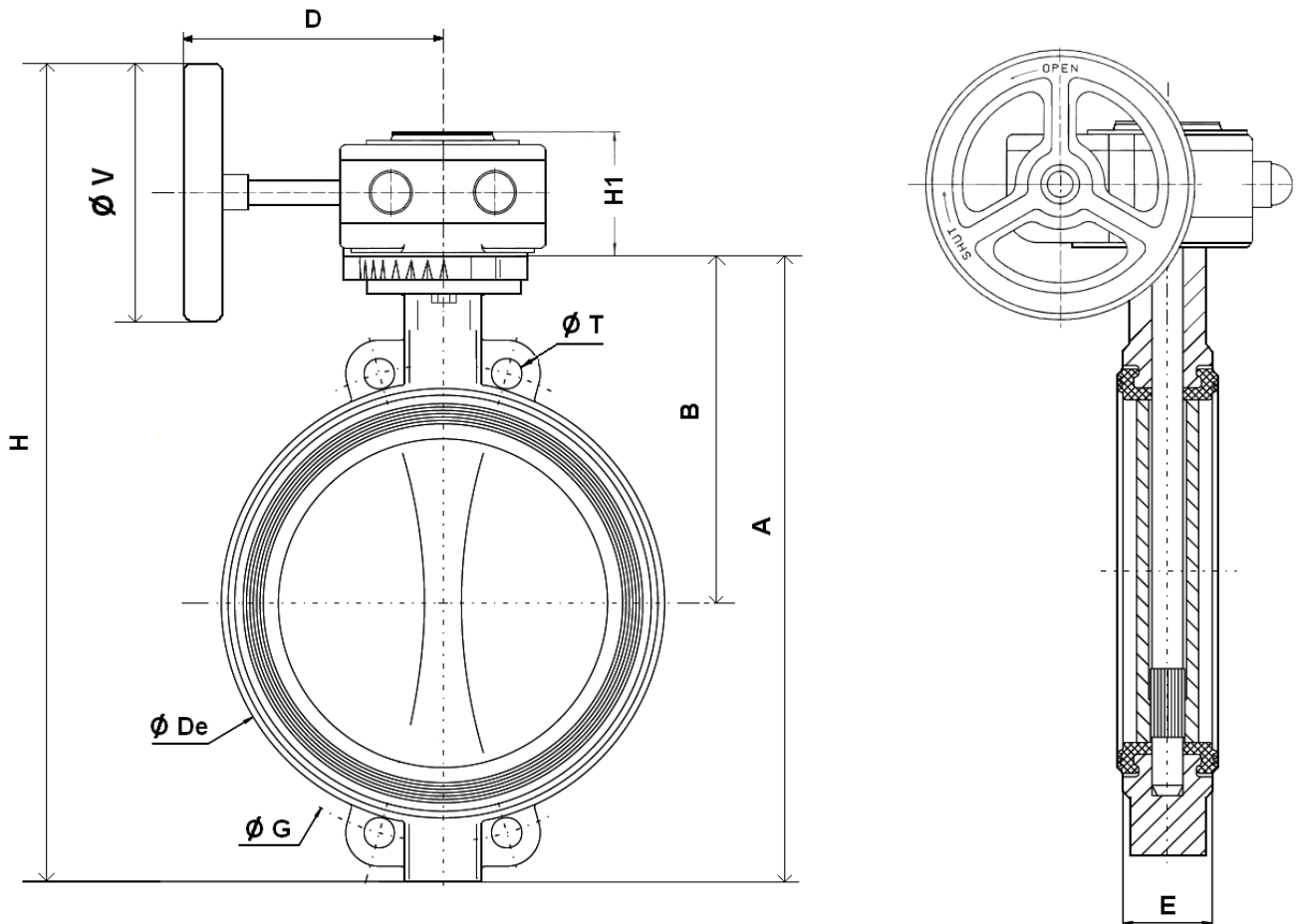

DN	32/40	50	65	80	100	125	150	200	250	300	350	400
A	206	228	248	265	298	331	349	430	461	524	570	644
B	140	156	161	169	187	206	215	255	248	280	300	340
Ø De	82	102	119	135	155	185	208	270	328	381	437	486
D	120	120	120	120	120	136	136	136	223	223	345	345
E	33	43	46	46	52	56	56	60	68	78	78	102
H	304	326	341	364	392	452	477	566	647	709	831	894
H1	58	58	58	58	58	58	58	58	74	74	98	98
Ø G	110	125	145	160	180	210	240	295	350	400	460	515
Ø T	18	18	18	18	18	18	23	23	23	23	23	27
Ø V	140	140	140	140	140	200	200	200	300	300	400	400
Weight (Kg)	3.81	5.01	5.75	5.95	7.35	9.35	10.95	16.45	28.7	37	48.5	61.5

**WAFER BUTTERFLY VALVE EXCELLENCE RANGE  
STAINLESS STEEL BODY AND DISC WITH EPDM SEAT**

SIZE PN10 ( in mm ) :

Valves with gearbox DN 450 - 600 :

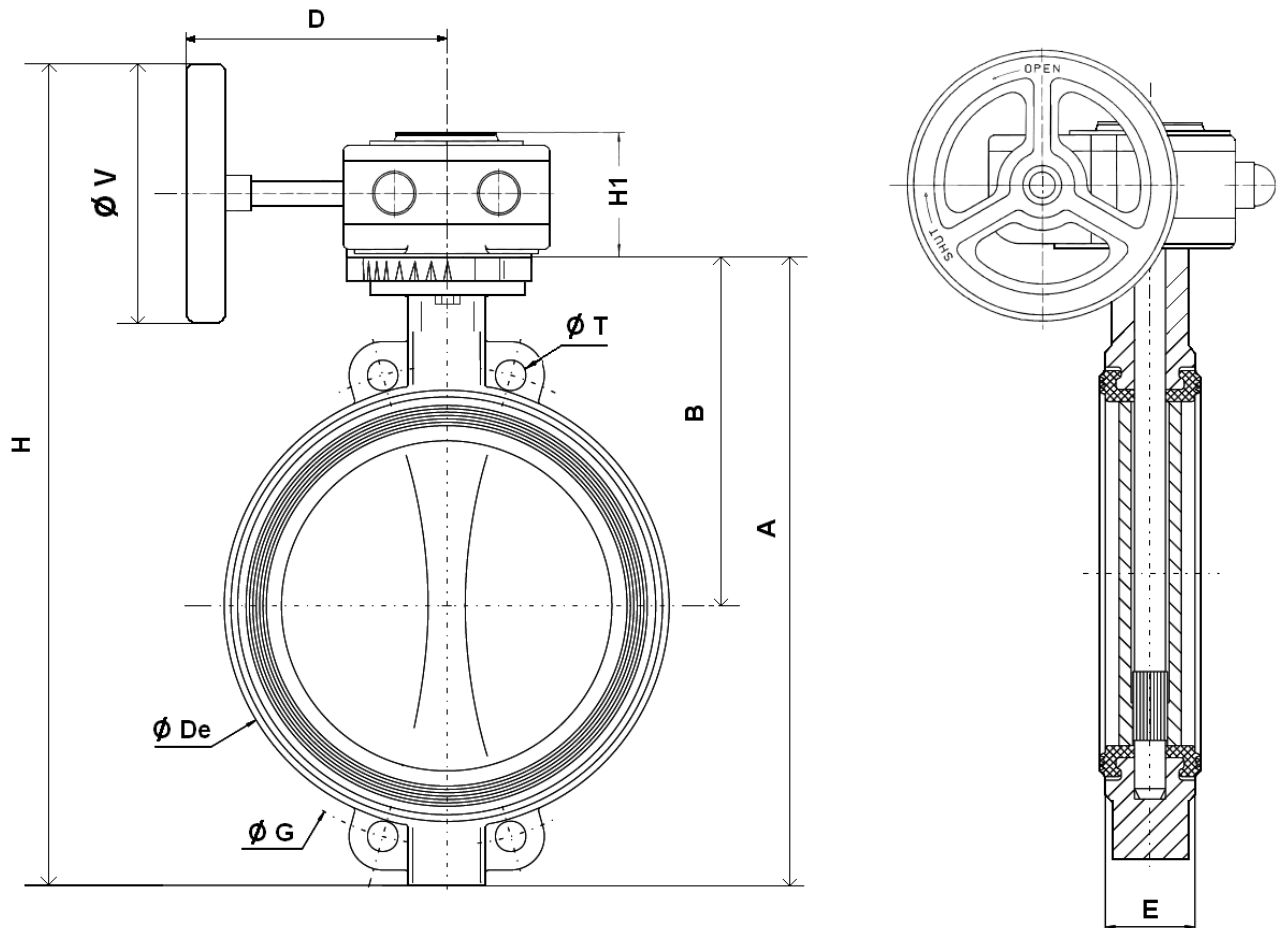

DN	450	500	600
A	738	822	965
B	394	440	507
Ø De	538	595	695
D	364	386	421
E	114	127	154
H	1083	1171	1376
H1	90	98	122
Ø G	565	620	725
Ø T	M24	M24	M27
Ø V	600	600	700
Weight ( Kg )	105.8	143.8	215.3

**WAFER BUTTERFLY VALVE EXCELLENCE RANGE  
STAINLESS STEEL BODY AND DISC WITH EPDM SEAT**

SIZE PN10 ( in mm ) :

Valves with chain gearbox :

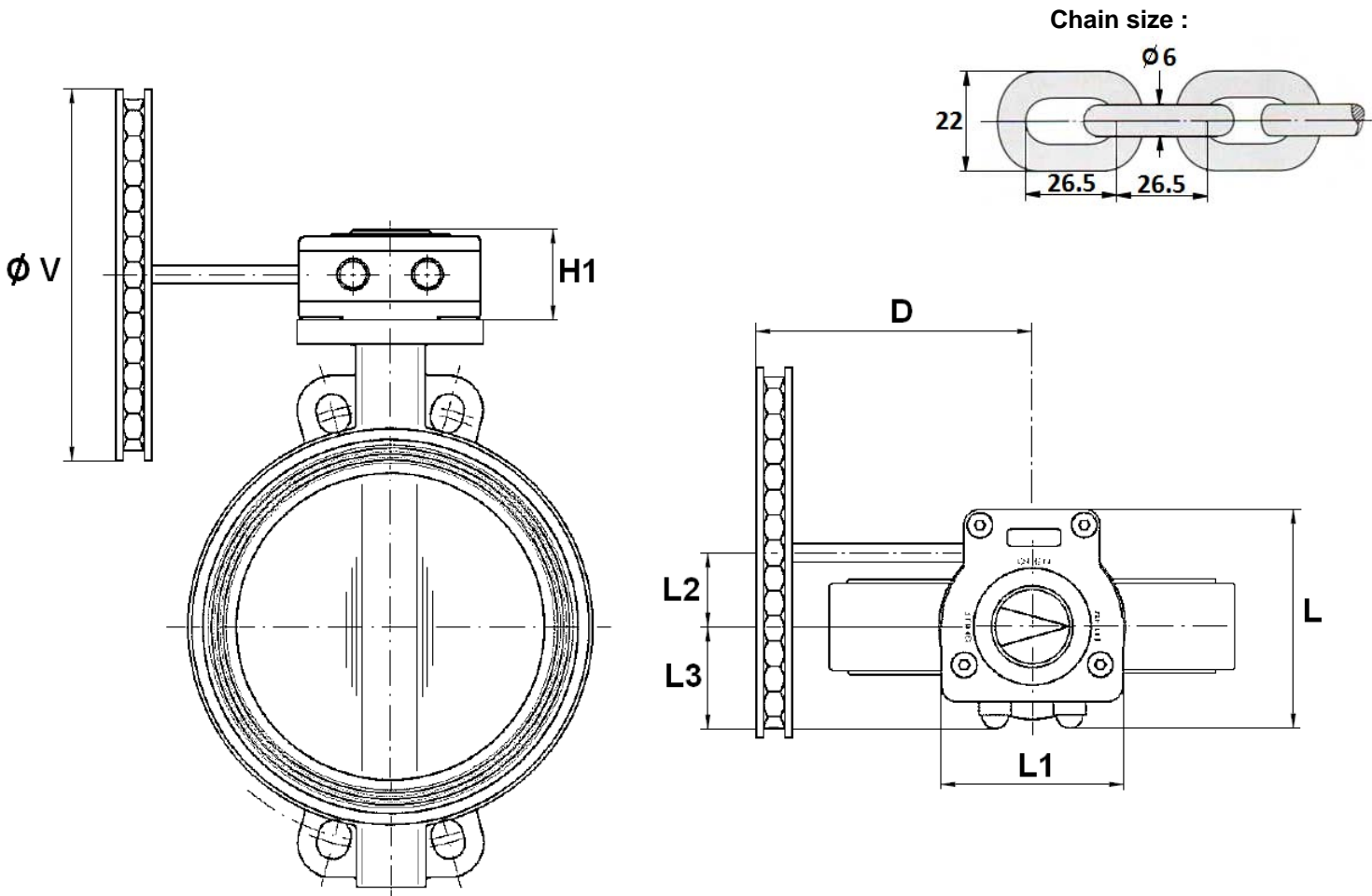

DN	32/40	50	65	80	100	125	150	200	250	300	350	400	450	500
D	120	120	120	120	120	126	126	126	214	214	331	331	350	365
H1	58	58	58	58	58	58	58	58	74	74	98	98	90	98
L	128	128	128	128	128	128	128	128	175	175	224	224	232	267
L1	100	100	100	100	100	100	100	100	142	142	185	185	204	227
L2	50	50	50	50	50	50	50	50	61	61	80	80	86	104.5
L3	56	56	56	56	56	56	56	56	80	80	98	98	100	110
$\phi V$	160	160	160	160	160	210	210	210	300	300	400	400	500	500
Weight ( Kg )	4.81	6.01	6.75	6.95	8.35	10.35	11.95	17.45	31.5	39.8	53.3	66.3	113.2	150.7



**WAFER BUTTERFLY VALVE EXCELLENCE RANGE  
 STAINLESS STEEL BODY AND DISC WITH EPDM SEAT**

**GEARBOX SPECIFICATIONS :**

DN	32/50	65	80/100	125/150	200	250	300	350
Ref.	1197050	1197065	1197100	1197150	1197200	1197250	1197300	1197350
Ratio factor	37 : 1	37 : 1	37 : 1	37 : 1	37 : 1	36 : 1	36 : 1	50 : 1
Turns number for closing / opening	9.25	9.25	9.25	9.25	9.25	9	9	12.5
Input torque (Nm)	12.5	12.5	12.5	12.5	12.5	23	23	50
Output torque (Nm)	300	300	300	300	300	675	675	1310

DN	400	450	500	600
Ref.	1197400	1197451	1197501	1197601
Ratio factor	50 : 1	38 : 1	55 : 1	52 : 1
Turns number for closing / opening	12.5	9.5	13.75	13
Input torque (Nm)	50	86	96	160
Output torque (Nm)	1310	1620	2640	4160

**WAFER BUTTERFLY VALVE EXCELLENCE RANGE  
STAINLESS STEEL BODY AND DISC WITH EPDM SEAT**

NECK AND DISC SIZE ( in mm ) :

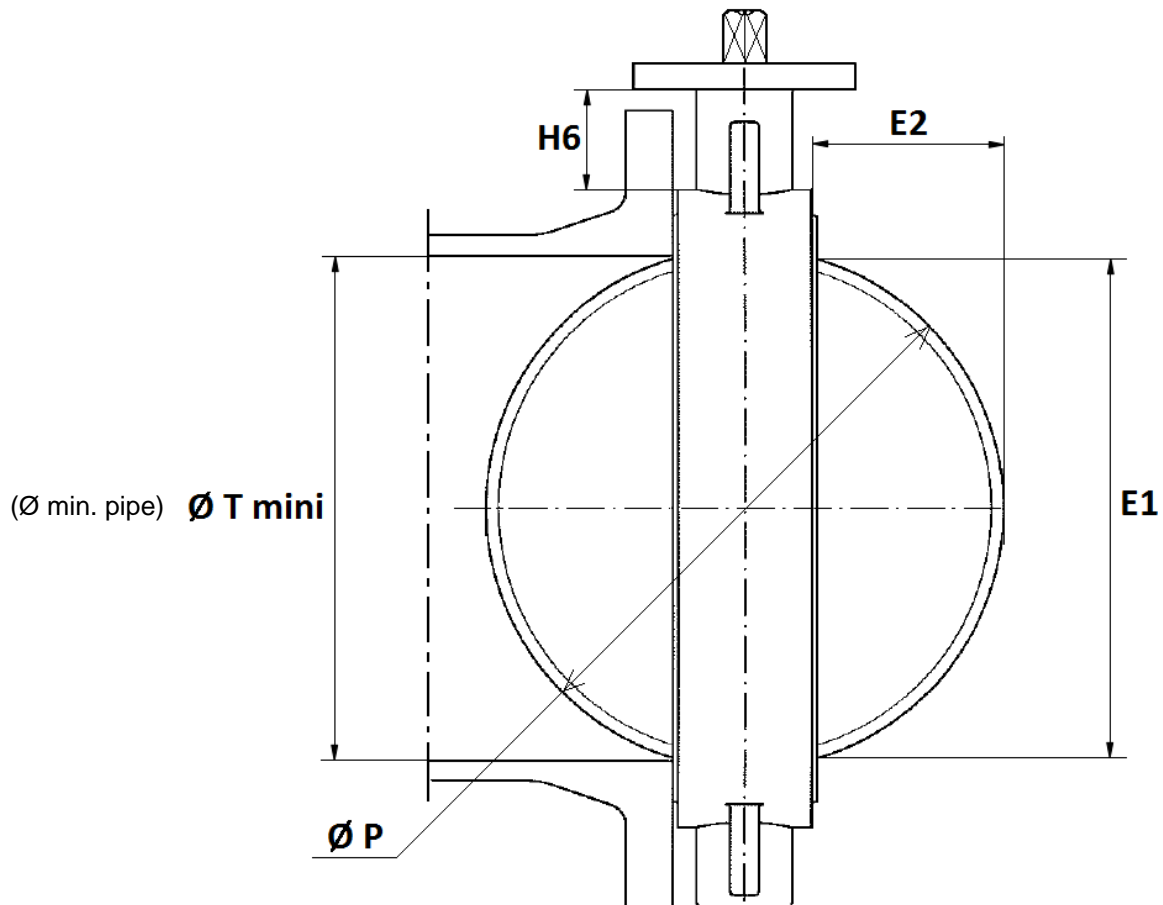

DN	32/40	50	65	80	100	125	150	200	250	300	350	400	450	500	600
E1	23	24.5	46	65	85	109	136	188	238	289	331	385	424	479	575
E2	3.5	3.5	9.5	17	24	33.5	45.5	69	90	110.5	131	148	162.5	184	221
H6	76	82	80	80	88	93	89	99	71	76	69	80	96	119	127
Ø T mini	26	27.5	49	68	88	112	139	191	241	292	334	388	427	482	578
Ø P	40	50	65	80	100	123	147	198	248	299	340	398	439	495	596

**WAFER BUTTERFLY VALVE EXCELLENCE RANGE  
STAINLESS STEEL BODY AND DISC WITH EPDM SEAT**

SIZE ( in mm ) :

Square lever for special key ( 30x30 mm ) :

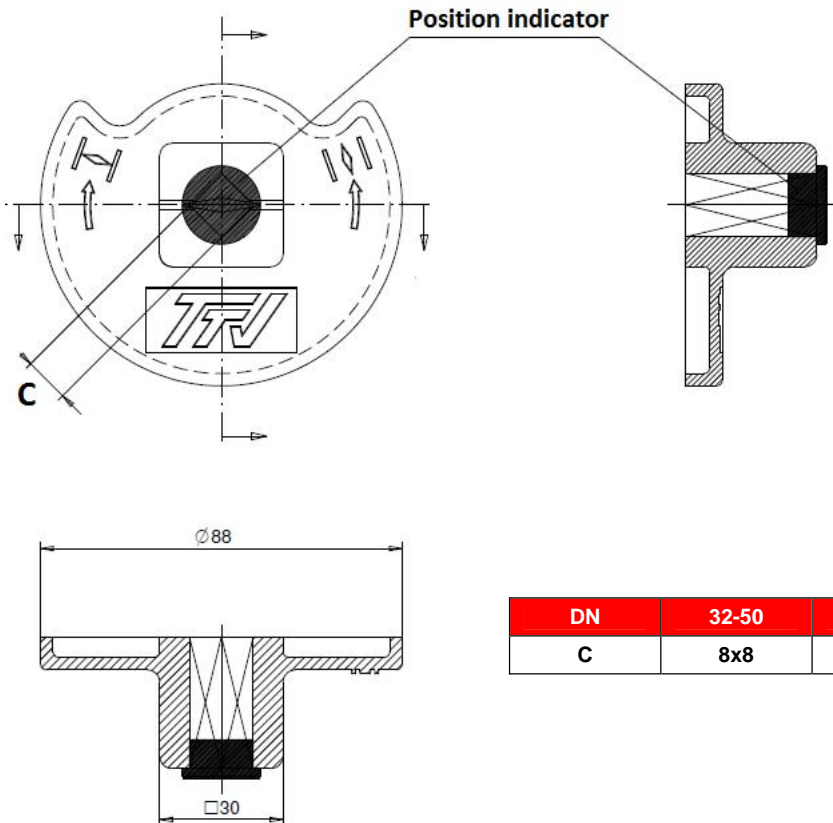

**WAFER BUTTERFLY VALVE EXCELLENCE RANGE  
STAINLESS STEEL BODY AND DISC WITH EPDM SEAT**

ISO MOUNTING PAD SIZE DN32-400 ( in mm ) :

**DN 32 – 200**

**DN250-400**

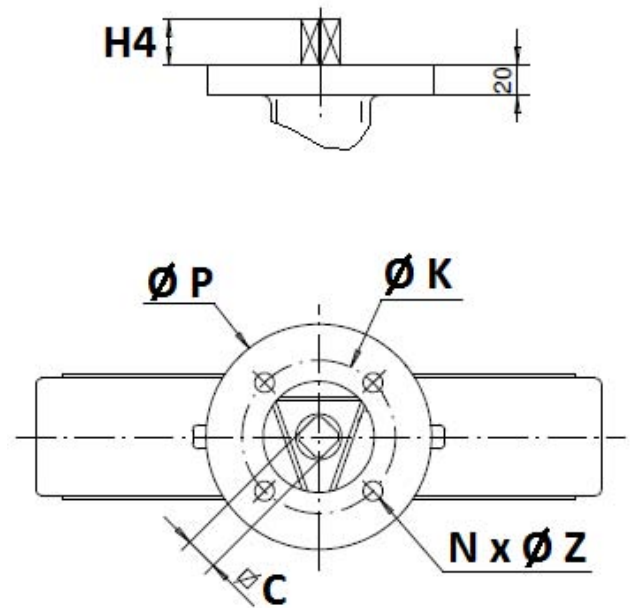
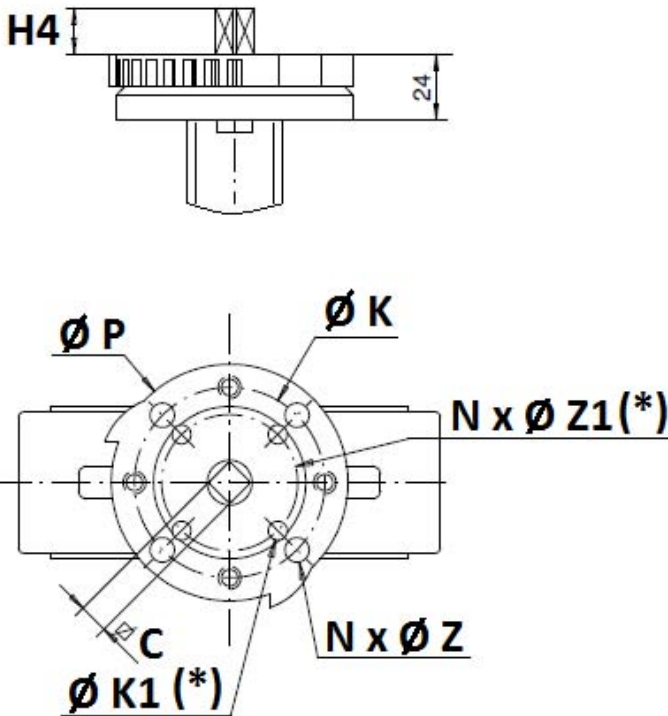

(\*) : Only from DN32 to DN100

DN	32/40	50	65	80	100	125	150	200	250	300	350	400
H4	14	14	16	16	20	20	20	24	24	24	29	29
C	8	8	9	11	11	14	14	17	19	22	22	27
Ø K	70	70	70	70	70	70	70	70	102	102	140	140
ISO	F07	F07	F07	F07	F07	F07	F07	F07	F10	F10	F14	F14
N x Ø Z	4 x 9	4 x 9	4 x 9	4 x 9	4 x 9	4 x 9	4 x 9	4 x 9	4 x 11	4 x 11	4 x 18	4 x 18
Ø K1	50	50	50	50	50	-	-	-	-	-	-	-
ISO 1	F05	F05	F05	F05	F05	-	-	-	-	-	-	-
N x Ø Z1	4 x 7	4 x 7	4 x 7	4 x 7	4 x 7	-	-	-	-	-	-	-

**WAFER BUTTERFLY VALVE EXCELLENCE RANGE  
STAINLESS STEEL BODY AND DISC WITH EPDM SEAT**

ISO MOUNTING PAD SIZE DN450-600 ( in mm ) :

**DN 450 - 600**

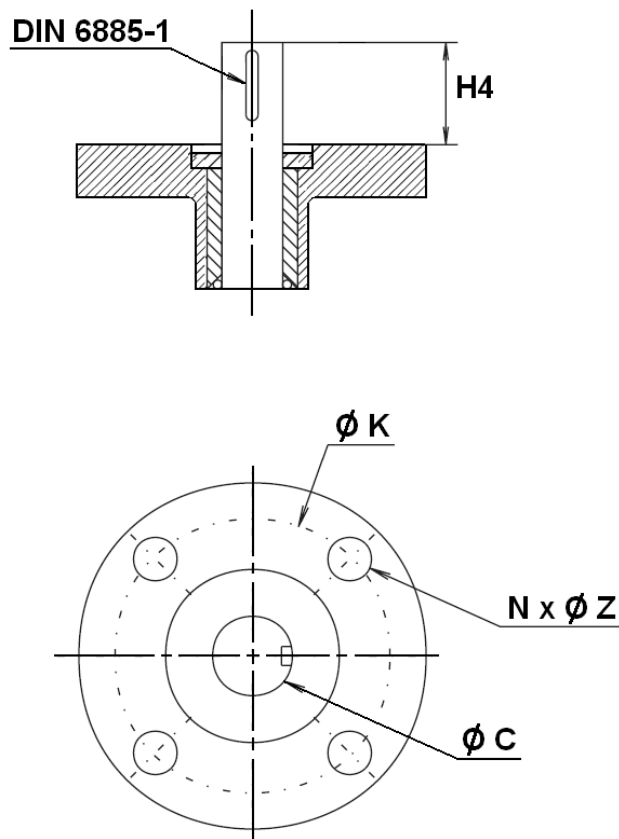

DN	450	500	600
H4	80	80	90
Ø C	50	50	60
Ø K	140	140	165
ISO	F14	F14	F16
N x Ø Z	4 x 18	4 x 18	4 x 22

**WAFER BUTTERFLY VALVE EXCELLENCE RANGE  
STAINLESS STEEL BODY AND DISC WITH EPDM SEAT**

**STANDARDS :**

Fabrication according to ISO 9001:2008

Designing according to ISO 10631

DIRECTIVE 97/23/CE : CE N° 0038  
Risk Category III module H

Pressure tests according to ISO 5208, A class

Between flanges according to EN 1092-1 PN10/16

ISO 5211 mounting pad

Length according to ISO 5752 short series 20, EN 558 series 20 ( NF 29305 ),BS 5155 Wafer short/medium, DIN 3202 part 3, series K1

ATEX Group II Category 2 G/2D Zone 1 & 21 Zone 2 & 22 ( optional marking )

Approval certificate **Marine BUREAU VERITAS**, N° 14087/C0 BV from DN32 to 1000

OTAN agreement ( N° 286B )

**ADVICE :** Our opinion and our advice are not guaranteed and SFERACO shall not be liable for the consequences of damages.  
The customer must check the right choice of the products with the real service conditions.

**INSTALLATION INSTRUCTIONS**

**GENERAL GUIDELINES :**

Ensure that the valves to be used are appropriate for the conditions of the installation (type of fluid, pressure and temperature).

Be sure to have enough valves to be able to isolate the sections of piping as well as the appropriate equipment for maintenance and repair.

Ensure that the valves to be installed are of correct strength to be able to support the capacity of their usage.

**Installation of all circuits should ensure that their function can be automatically tested on a regular basis (at least two times a year).**

**WAFER BUTTERFLY VALVE EXCELLENCE RANGE  
STAINLESS STEEL BODY AND DISC WITH EPDM SEAT**

**INSTALLATION INSTRUCTIONS :**

**Before installing the valves, clean and remove any objects from the pipes** (in particular bits of sealing and metal) which could obstruct and block the valves.

**Ensure that both connecting pipes either side of the valve (upstream and downstream) are aligned** (if they're not, the valves may not work correctly).

**Make sure that the two sections of the pipe (upstream and downstream) match, the valve unit will not absorb any gaps. Any distortions in the pipes may affect the tightness of the connection, the working of the valve and can even cause a rupture.** To be sure, place the kit in position to ensure the assembling will work.

**If sections of piping do not have their final support in place, they should be temporarily fixed. This is to avoid unnecessary strain on the valve.**

The valve must be inserted between flanges with disc half opened but the disc must not overpass the valve thickness. Position the bolts to keep centered the valve. Then open fully the valve and tighten the bolts.

**See graph under.**

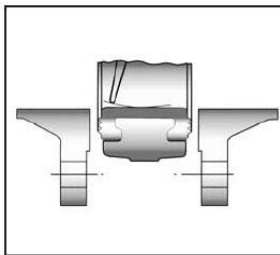

Half open valve introduction

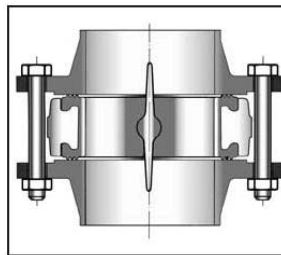

Complete opened disc valves when screw tightening

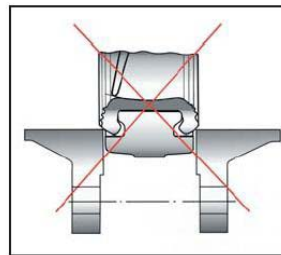

Tighten the bolts in cross.

The disc must move easily inside the pipe.

Valves must be opened during cleaning operation.

Tests must be done with a cleaned pipe.

Tests must be done with opened valve. Test pressure must not be higher than the valve specification according to ISO 5208.

Then open slowly the valve.

**Do not mount butterfly valves with stainless steel pressed collars and turning flanges without strias.**

**And not on flat face flanges without strias ( example : painted cast iron fittings )**

**MAINTENANCE :**

We recommend to operate fully the valve 1 to 2 times per year.

During maintenance operation, ensure that the pipe isn't under pressure, that there's no fluid in the pipe and that the valve is isolated. If there's a fluid in the pipe, evacuate it. Ensure that there are no risks due to the temperature or the fluid ( like acids ). If the fluid is corrosive, inert the installation before maintenance operation.