

**LUG BUTTERFLY VALVE PERFORMANCE RANGE  
DUCTILE IRON BODY WITH STAINLESS STEEL DISC AND EPDM HT SEAT**

**armat**  
spol. s r.o.  
MADE OF STAINLESS ...



**Certificate 3.1**



**Size :** DN 40 to 600 mm  
**Ends :** Between flanges PN10/16  
**Min Temperature :** - 10°C  
**Max Temperature :** + 130°C  
**Max Pressure :** 16 Bars up to DN300, 10 bars over  
**Specifications :** Long neck for isolation  
Stainless steel disc  
Full crossing stem (up to DN65)  
EPDM HT seat  
With ISO 5211 mounting pad

**Materials :** Ductile iron body EN GJS-400-15

**LUG BUTTERFLY VALVE PERFORMANCE RANGE  
 DUCTILE IRON BODY WITH STAINLESS STEEL DISC AND EPDM HT SEAT**

**SPECIFICATIONS :**

Long neck for isolation  
 ISO 5211 mounting pad  
 Lug type  
 Between flanges PN10/16  
 Full crossing stem (up to DN65)  
 Removable EPDM HT seat  
 9 positions lever up to DN150 and 12 positions lever from DN200 to 300, locking device in opened position  
 Stainless steel disc  
 Epoxy RAL 5012 electrostatic painting coated body, 250 $\mu$  thickness

**USE :**

Cold and hot water, sea water, demineralized water, alcohol, milk of lime, mercury, alcalins, hydroxid of soda  
 Min and max Temperature Ts : - 10°C to + 130°C  
 Max Pressure Ps : 16 bars up to DN300, 10 bars over

**RANGE :**

With lever from DN 40 to DN 300  
 With gearbox from DN350 to 600  
 Possible with gearbox **Ref. 1192** from DN 40 to DN 300

**ENDS :**

Between flanges PN10/16

**TORQUE VALUE ( Nm, without safety coefficient ) at 16 Bars :**

DN	40	50	65	80	100	125	150	200	250	300
Torque ( Nm )	11	15.1	17.2	23.1	39.8	61.9	102	192	323	490

**TORQUE VALUE ( Nm, without safety coefficient ) at 10 Bars :**

DN	350	400	450	500	600
Torque ( Nm )	550	755	1012	1350	2111

**LUG BUTTERFLY VALVE PERFORMANCE RANGE  
DUCTILE IRON BODY WITH STAINLESS STEEL DISC AND EPDM HT SEAT**

FLOW COEFFICIENTS Kv ( m<sup>3</sup> / h ) :

Kv	OPENING ANGLE								
	10°	20°	30°	40°	50°	60°	70°	80°	90°
50	0,05	2,6	6,0	13	23	38	60	90	99
65	0,09	5	10	21	39	64	102	153	168
80	0,17	8	15	33	60	99	157	236	259
100	0,26	15	31	67	119	197	312	468	514
125	0,43	25	52	114	203	336	531	797	876
150	0,69	39	81	176	314	518	821	1231	1353
200	1,7	76	161	350	623	1030	1631	2446	2687
250	2,6	129	274	595	1060	1754	2776	4164	4576
300	3	201	424	919	1638	2710	4289	6433	7069
350	5	290	613	1327	2366	3914	6195	9292	10212
400	7	398	842	1825	3254	5383	8519	12779	14043
450	9	527	1116	2418	4308	7129	11284	16925	18599
500	12	678	1411	3109	5540	9167	14508	21762	23914
600	19	1047	2217	4803	8560	14163	22414	33621	36946

HEAD LOSS GRAPH DN50-350 :

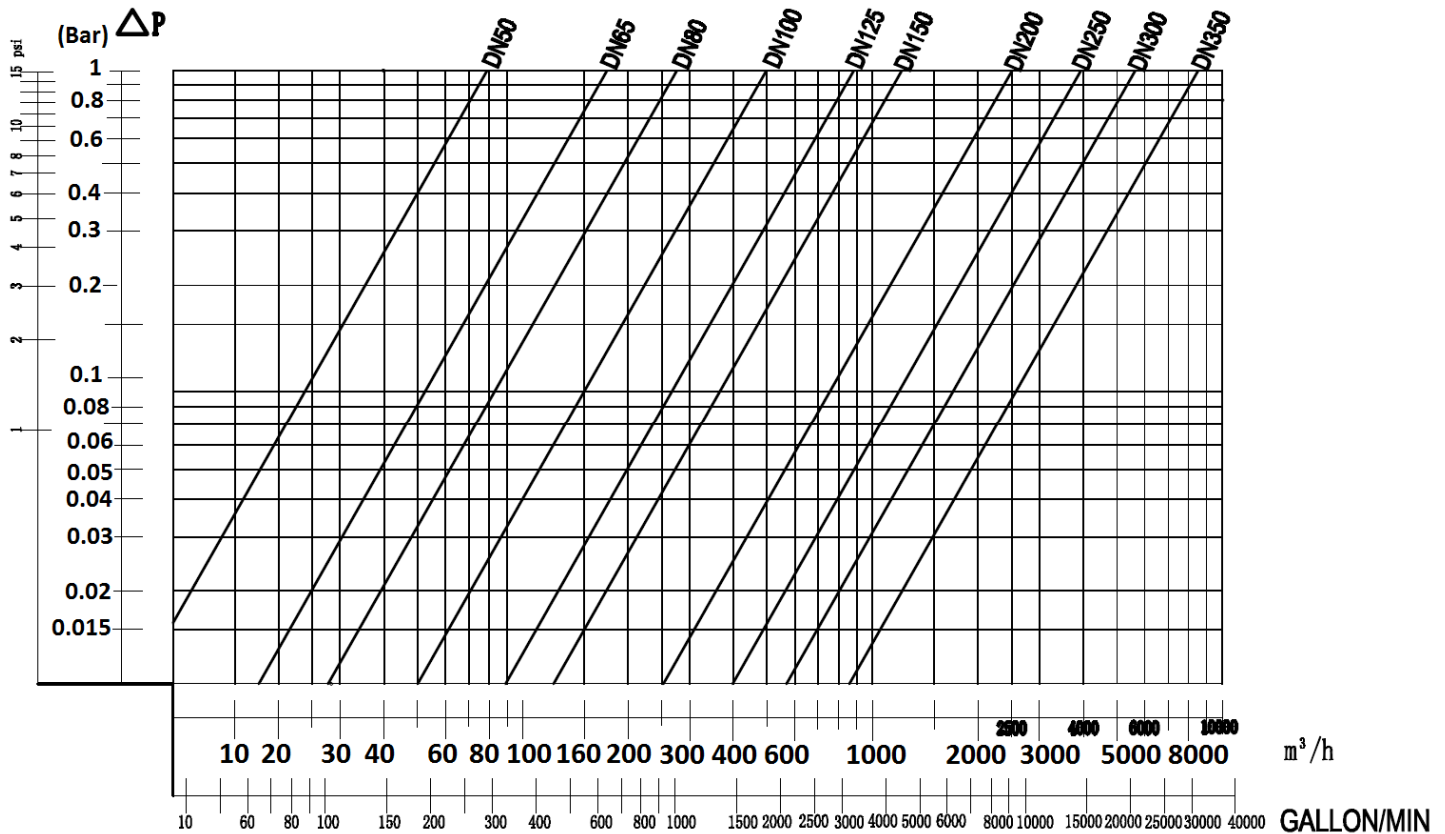

**LUG BUTTERFLY VALVE PERFORMANCE RANGE  
DUCTILE IRON BODY WITH STAINLESS STEEL DISC AND EPDM HT SEAT**

HEAD LOSS GRAPH DN400-600 :

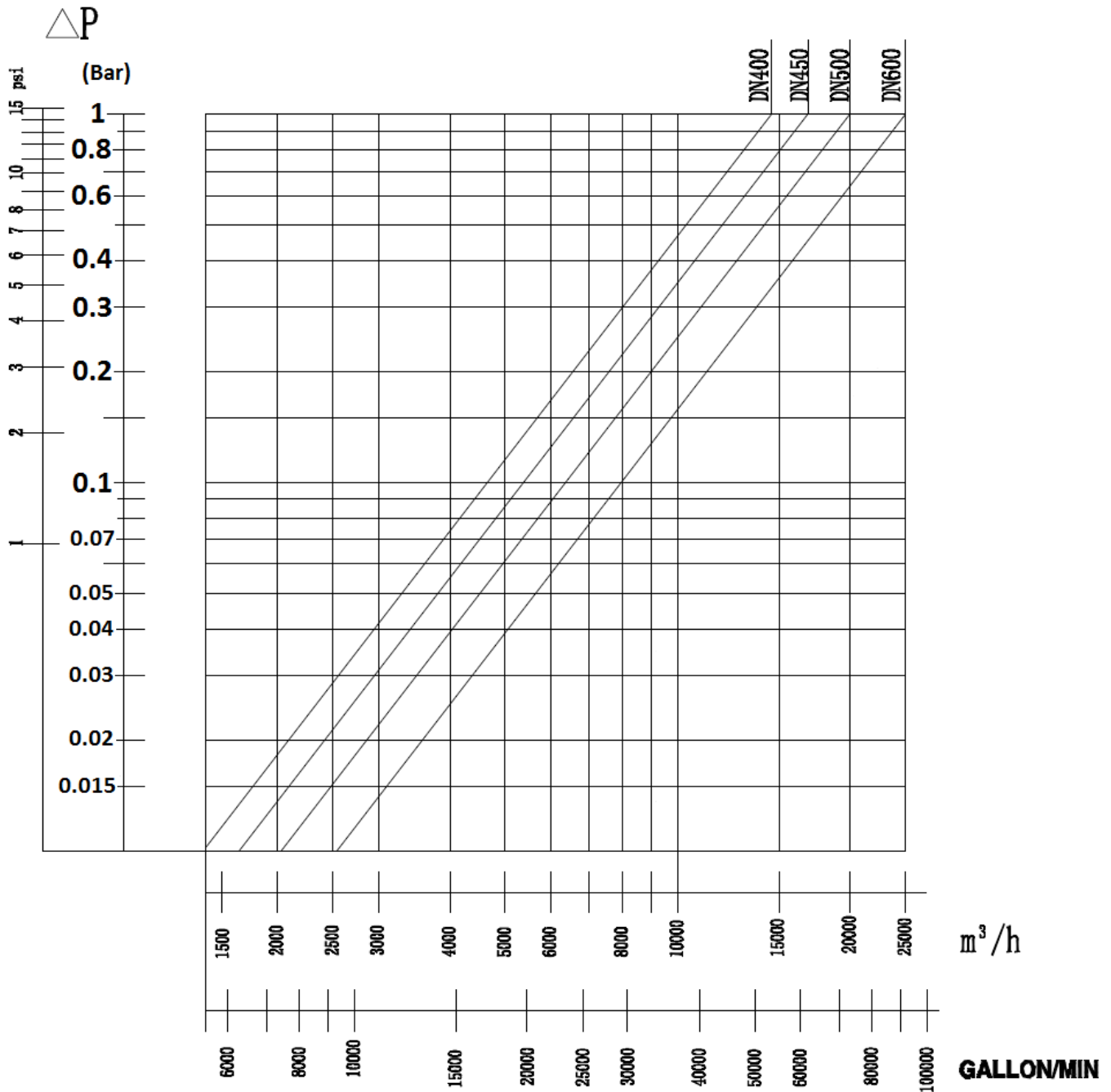

**LUG BUTTERFLY VALVE PERFORMANCE RANGE  
DUCTILE IRON BODY WITH STAINLESS STEEL DISC AND EPDM HT SEAT**

PRESSURE / TEMPERATURE GRAPH (STEAM EXCLUDED) :

Pressure

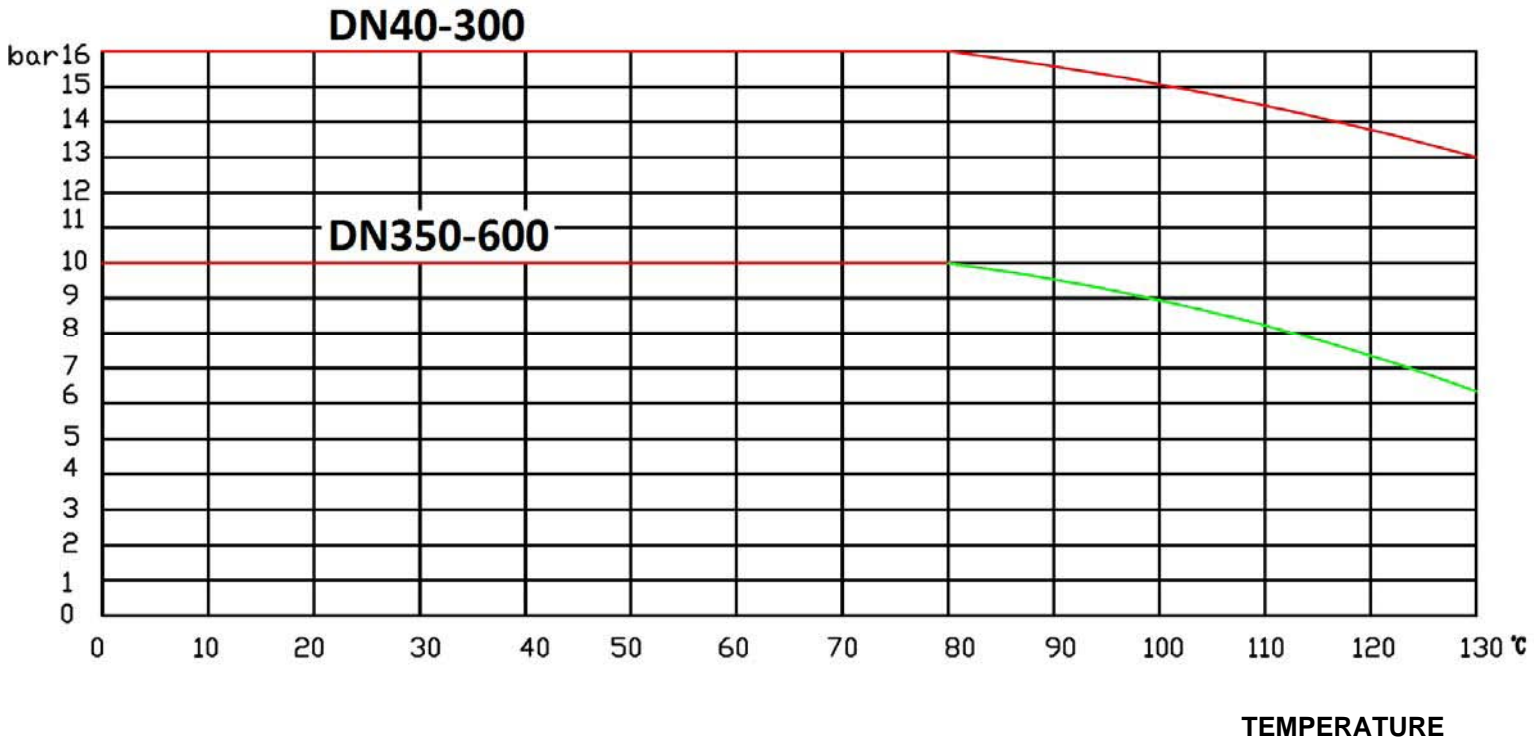

**LUG BUTTERFLY VALVE PERFORMANCE RANGE  
DUCTILE IRON BODY WITH STAINLESS STEEL DISC AND EPDM HT SEAT**

**MATERIALS :**

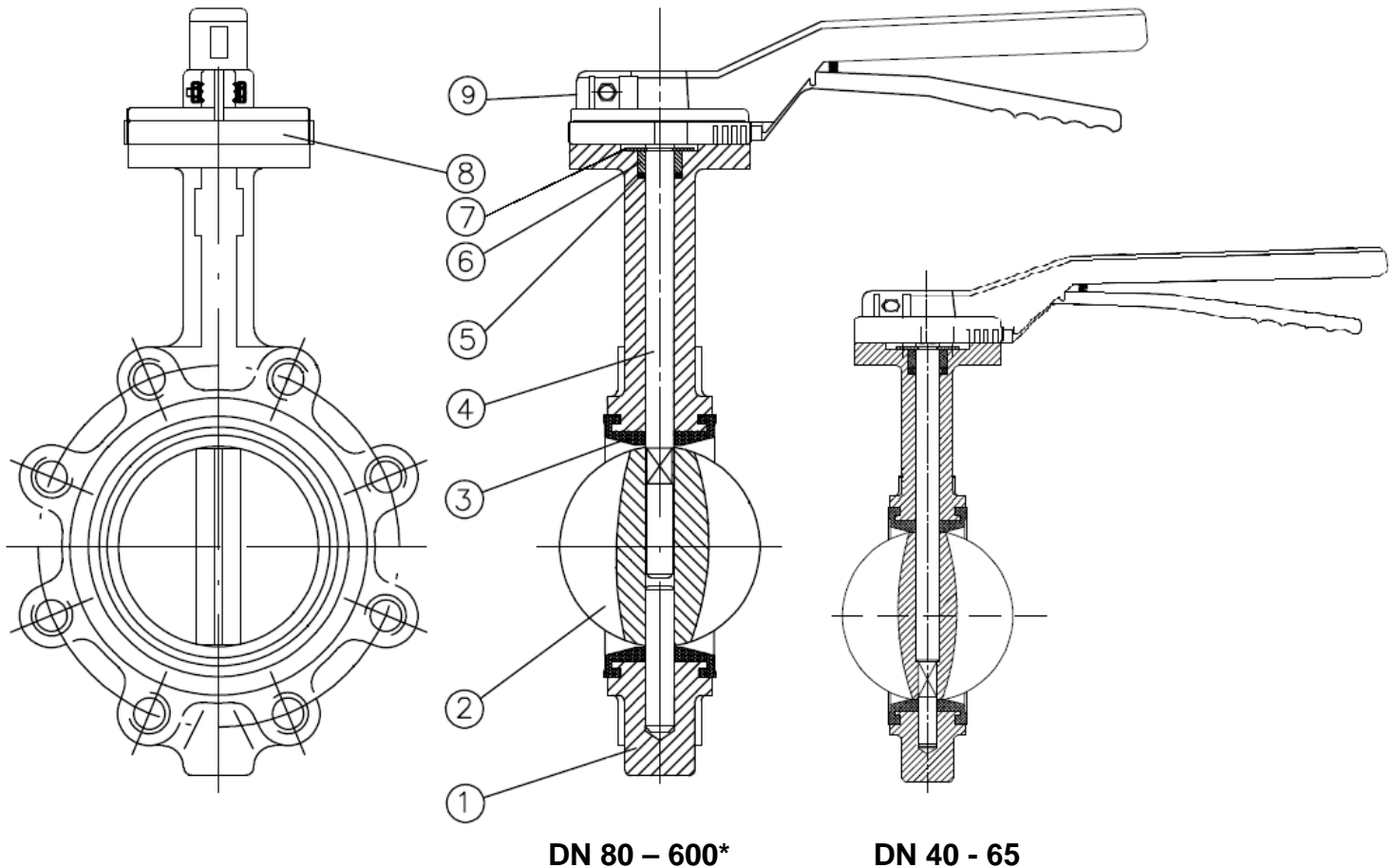

Item	Designation	Materials
1	Body	Ductile iron EN GJS-400-15
2	Disc	ASTM A351 CF8M
3	Seat	EPDM HT
4	Stem	SS 416
5	Gasket	NBR
6	Bushing	PTFE
7	Circlips	Steel
8	Plate	Aluminium
9 (*up to DN300)	Lever	Aluminium

**LUG BUTTERFLY VALVE PERFORMANCE RANGE  
DUCTILE IRON BODY WITH STAINLESS STEEL DISC AND EPDM HT SEAT**

VALVE SIZE PN16 ( in mm ) DN40-300 :

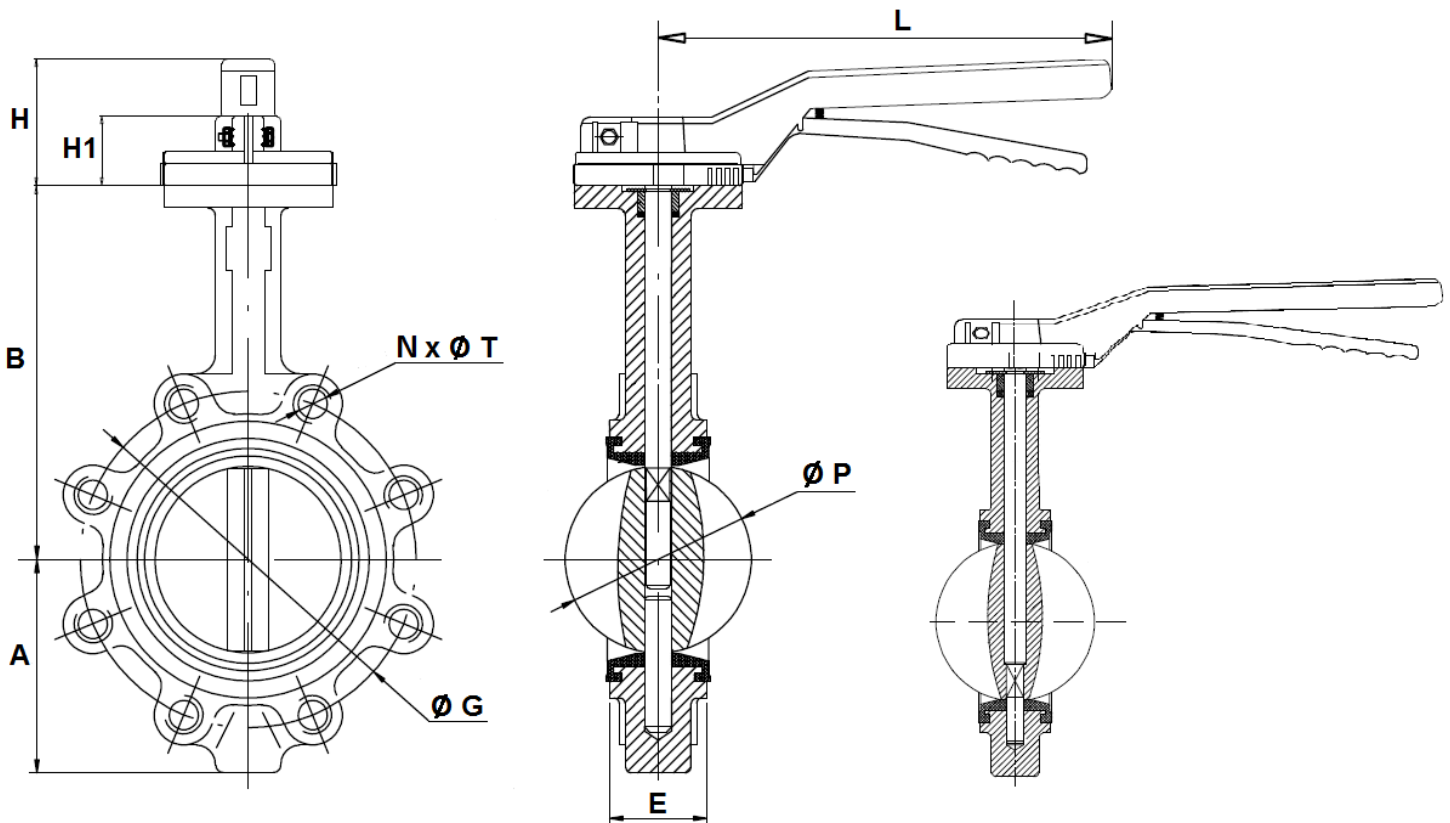

**DN 80 – 300**

**DN 40 - 65**

DN	40	50	65	80	100	125	150	200	250	300
Ø P	42.9	52.7	64.4	78.9	104.1	123.4	155.7	202.5	250.5	301.5
L	200	200	200	200	200	325	325	400	400	400
E	33	43	46	46	52	56	56	60	68	78
H1	43	43	43	43	43	43	43	46	46	46
H	74	74	74	74	74	75	75	75	75	75
B	120	140	150	158	176	190	211	235	265	305
A	57	65	75	93	108	125	135	170	205	238
N x Ø T	4 x M16	4 x M16	4 x M16	8 x M16	8 x M16	8 x M16	8 x M20	12x M20	12x M24	12x M24
Ø G	110	125	145	160	180	210	240	295	355	410
Weight (Kg)	3	4	4.6	6	7.7	9.9	12.4	20.7	30.4	42.4
Ref.	1176040	1176050	1176065	1176080	1176100	1176125	1176150	1176201	1176251	1176301

**LUG BUTTERFLY VALVE PERFORMANCE RANGE  
DUCTILE IRON BODY WITH STAINLESS STEEL DISC AND EPDM HT SEAT**

VALVE SIZE PN10 ( in mm ) DN200-300 :

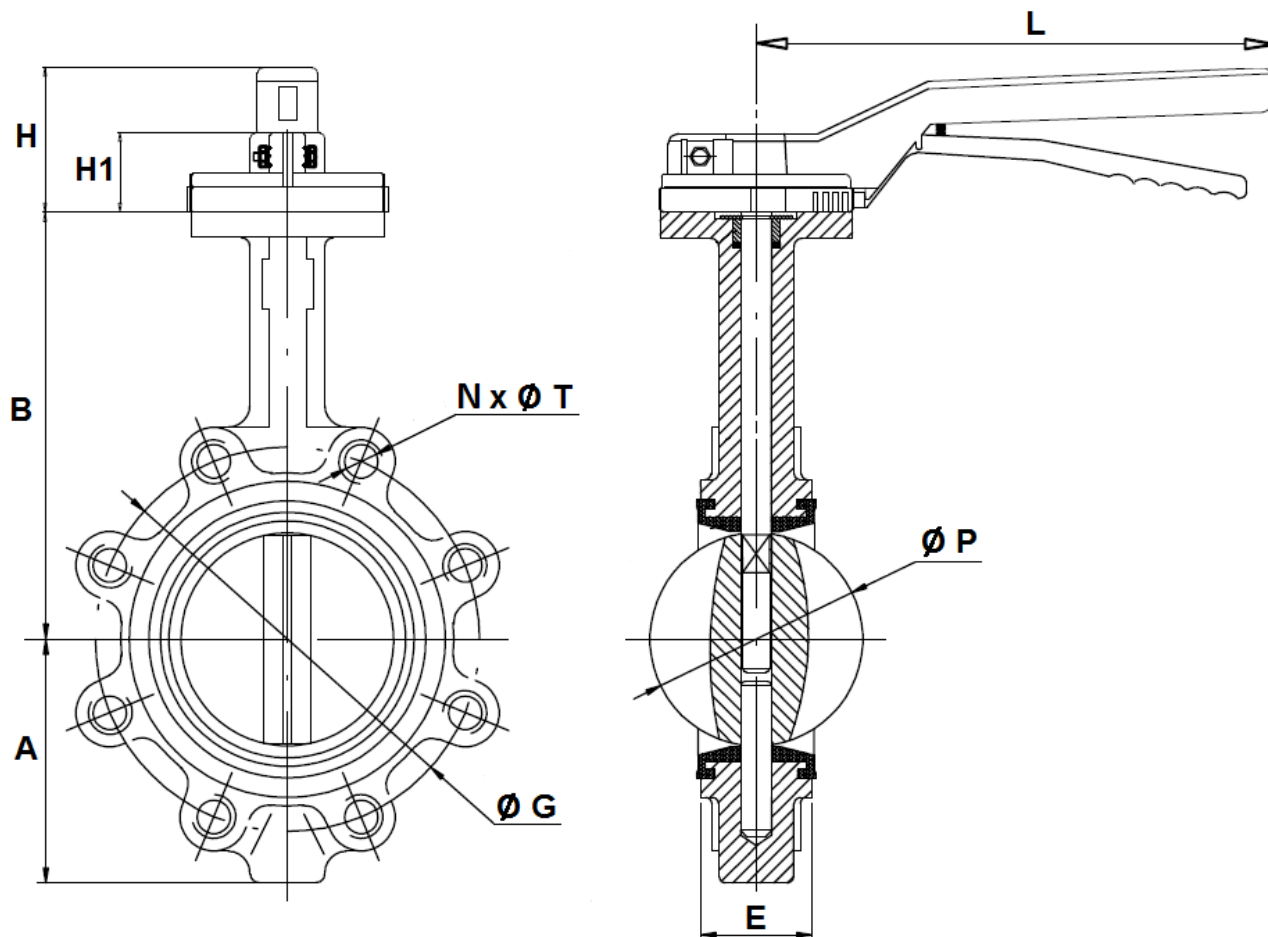

DN	200	250	300
Ø P	202.5	250.5	301.5
L	400	400	400
E	60	68	78
H1	46	46	46
H	75	75	75
B	235	265	305
A	170	205	238
N x Ø T	8x M20	12x M20	12x M20
Ø G	295	350	400
Weight (Kg)	20.2	30.4	42.4
Ref.	1176200	1176250	1176300



**LUG BUTTERFLY VALVE PERFORMANCE RANGE  
DUCTILE IRON BODY WITH STAINLESS STEEL DISC AND EPDM HT SEAT**

VALVE SIZE PN16 ( in mm ) DN350-600 :

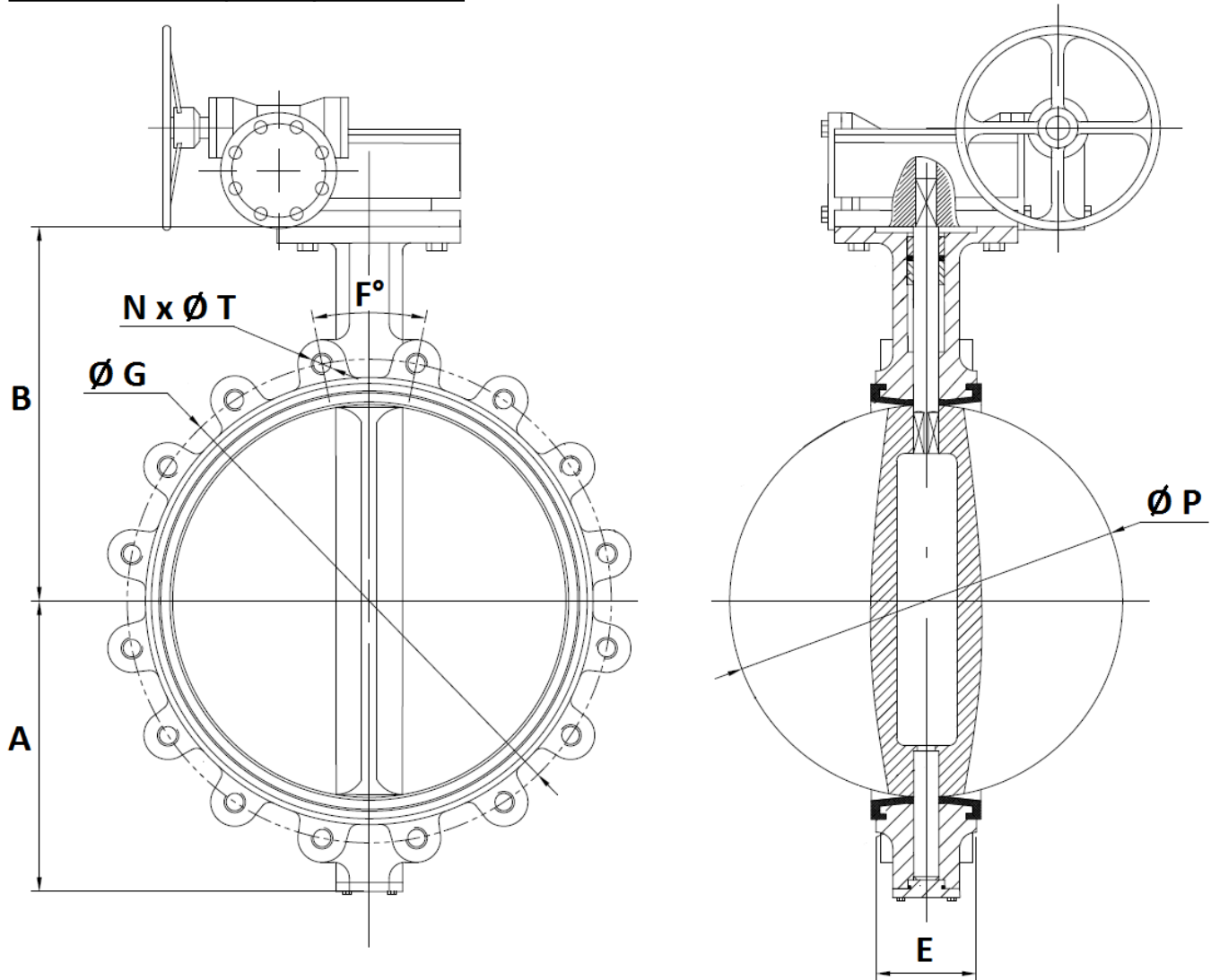

DN	350	400	450	500	600
Ø P	333.9	380.2	433.3	491.8	571.5
E	78	102	114	127	154
B	368	400	422	480	562
A	267	309	328	361	459
F°	22.5	22.5	18	18	18
N x Ø T	16 x M24	16 x M27	20 x M27	20 x M30	20 x M33
Ø G	470	525	585	650	770
Weight (Kg)	71	153	179	259	342
Ref.	1176351	1176401	1176451	1176501	1176601

**LUG BUTTERFLY VALVE PERFORMANCE RANGE  
DUCTILE IRON BODY WITH STAINLESS STEEL DISC AND EPDM HT SEAT**

VALVE SIZE PN10 ( in mm ) DN350-600 :

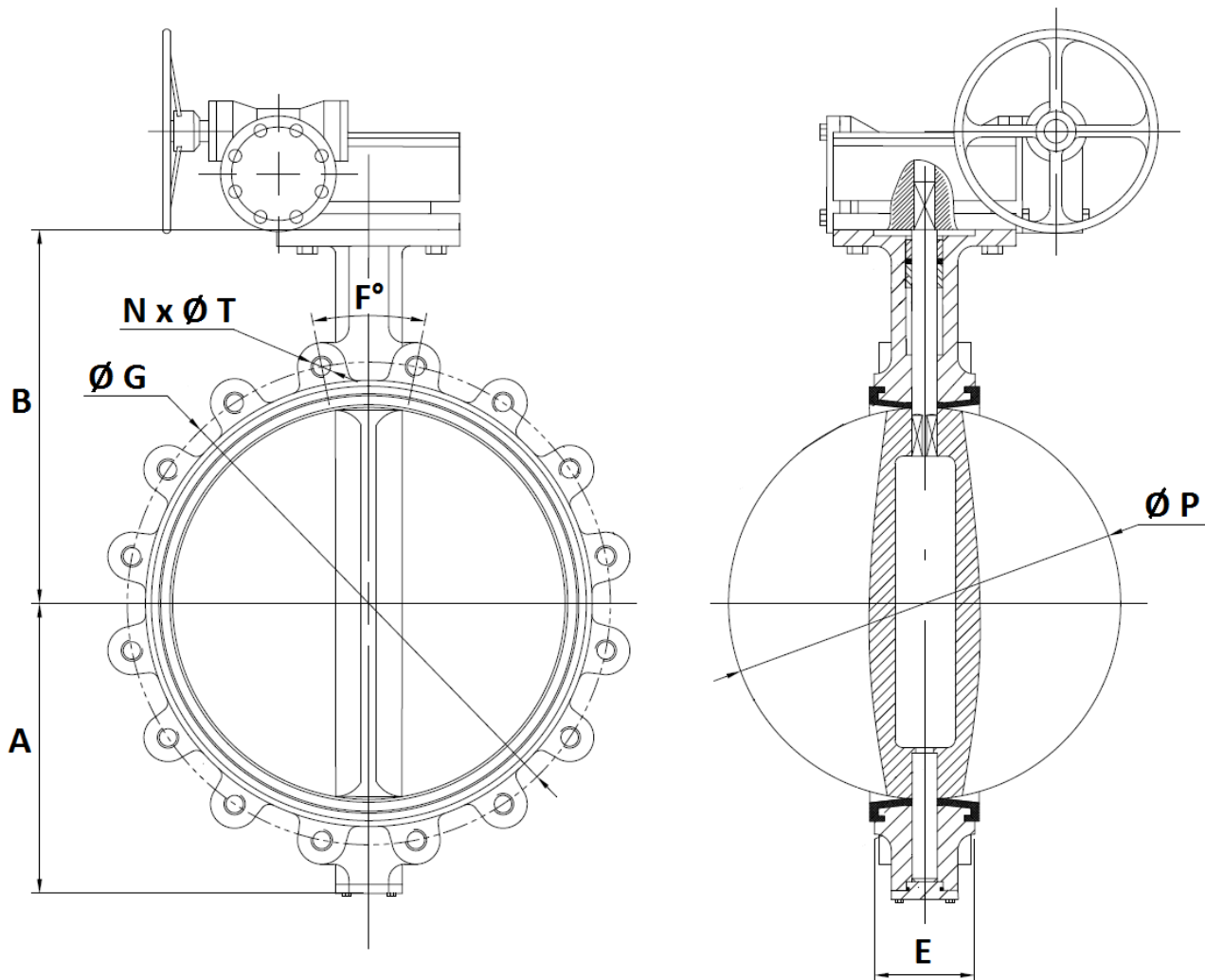

DN	350	400	450	500	600
Ø P	333.9	380.2	433.3	491.8	571.5
E	78	102	114	127	154
B	368	400	422	480	562
A	267	309	328	361	459
F°	22.5	22.5	18	18	18
N x Ø T	16 x M20	16 x M24	20 x M24	20 x M24	20 x M27
Ø G	460	515	565	620	725
Weight (Kg)	71	153	179	259	342
Ref.	1176350	1176400	1176450	1176500	1176600

**LUG BUTTERFLY VALVE PERFORMANCE RANGE  
DUCTILE IRON BODY WITH STAINLESS STEEL DISC AND EPDM HT SEAT**

GEARBOX SIZE REF.1192 ( in mm ) DN32/40-350 :

**DN 32/40 – 250**

**DN 300-350**

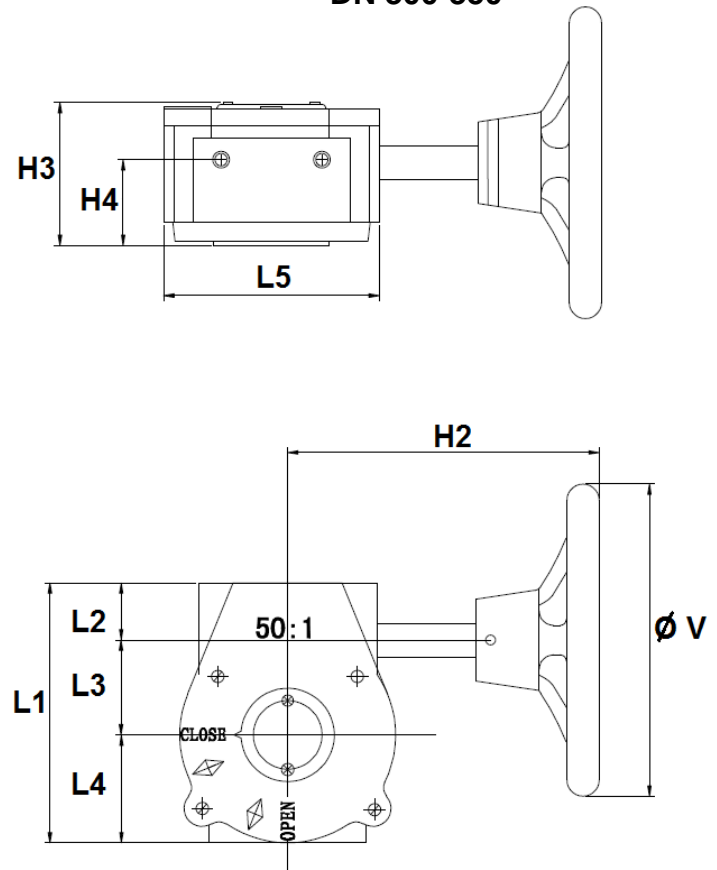
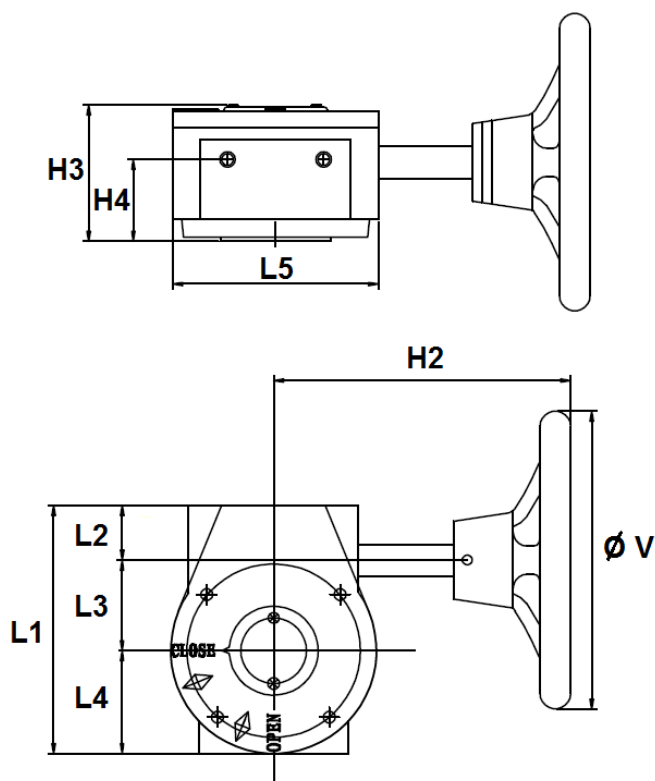

Ref.	DN	32/40 – 80	100	125 – 150	200	250	300	350
1192	Ø V	150	150	150	300	300	300	300
	H2	156	156	156	220	220	225	225
	H3	72	72	72	85	85	82	82
	H4	43	43	43	45	45	45	45
	L1	125	125	125	170	170	185	185
	L2	30	30	30	33	33	32.5	32.5
	L3	45	45	45	66	66	77.5	77.5
	L4	50	50	50	71	71	75	75
	L5	104	104	104	146	146	155	155
	Weight (Kg)	3.8	3.8	3.8	8.1	8.1	9.8	9.8
	Ref.	1192001	1192002	1192003	1192004	1192005	1192006	-

**LUG BUTTERFLY VALVE PERFORMANCE RANGE  
DUCTILE IRON BODY WITH STAINLESS STEEL DISC AND EPDM HT SEAT**

GEARBOX SIZE DN400-600 ( in mm ):

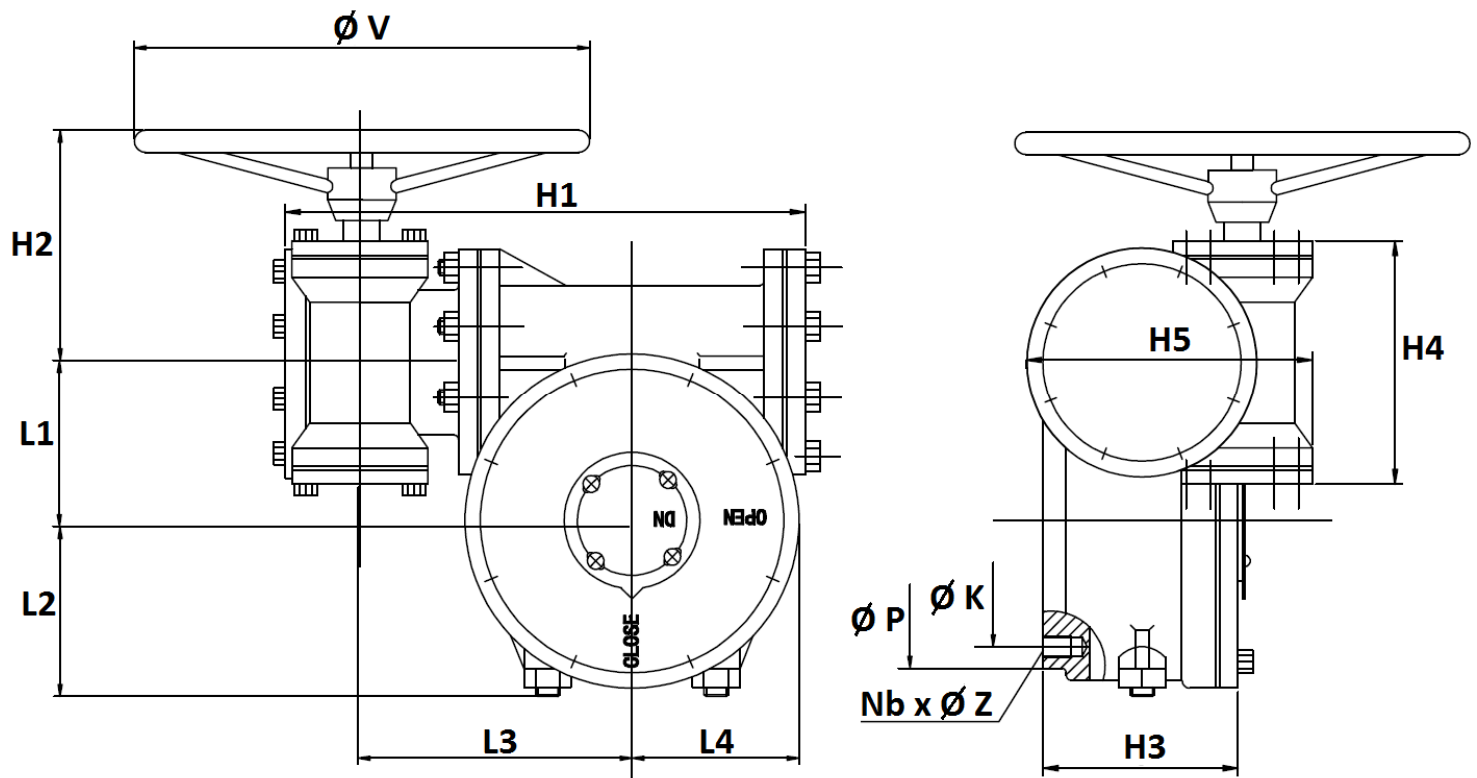

DN	400-500	600
Ø V	300	390
H1	320	386
H2	165	165
H3	135	140
H4	170	170
H5	185	185
L1	104	130
L2	110	135
L3	175	197
L4	100	145
Ø K (ISO)	140 (F14)	165 (F16)
Nb x ØZ	4 x M16	4 x M20
Ø P	175	210
Weight (Kg)	31	48

**LUG BUTTERFLY VALVE PERFORMANCE RANGE  
DUCTILE IRON BODY WITH STAINLESS STEEL DISC AND EPDM HT SEAT**

DISC AND NECK SIZE ( in mm ) :

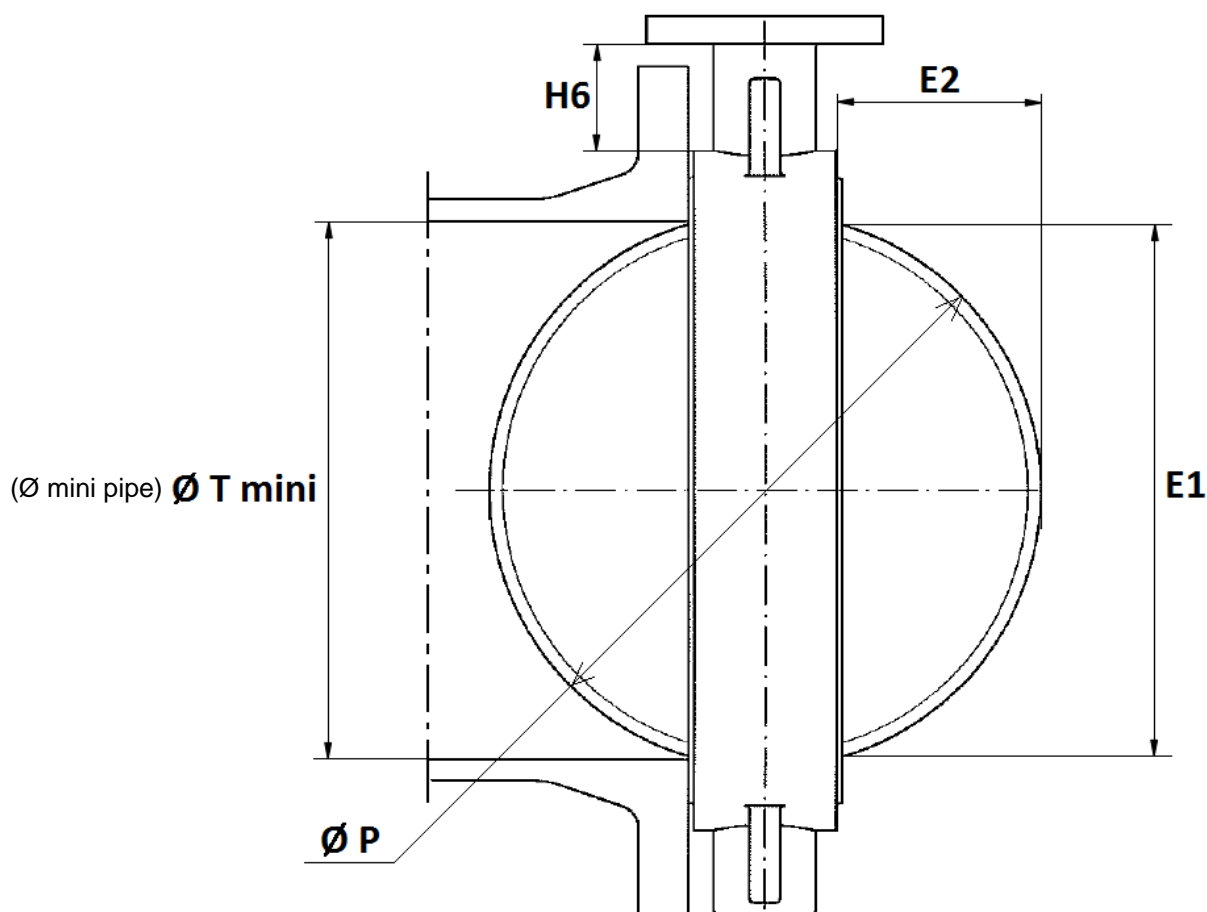

DN	32-40	50	65	80	100	125	150	200	250	300	350	400	450	500	600
E1	38.2	46.6	59.5	75.4	98.2	117.1	147.8	195.3	242.6	292.2	329	377.1	427.7	484.3	562.6
E2	4.95	4.85	9.2	16.45	26.05	33.7	49.85	71.25	91.25	111.75	127.95	139.1	159.65	182.4	208.75
H6 ±2	68	82.5	78.8	81.5	85.5	88	90.5	89	99	103	140	143	138	162	189
Ø P	42.9	52.7	64.4	78.9	104.1	123.4	155.7	202.5	250.5	301.5	333.9	380.2	433.3	491.8	571.5
Ø T mini	43	53	65	79.5	104.5	124	155.5	202.5	250.5	302	334	390	441	492	585

**LUG BUTTERFLY VALVE PERFORMANCE RANGE  
DUCTILE IRON BODY WITH STAINLESS STEEL DISC AND EPDM HT SEAT**

ISO MOUNTING PAD SIZE ( in mm ) :

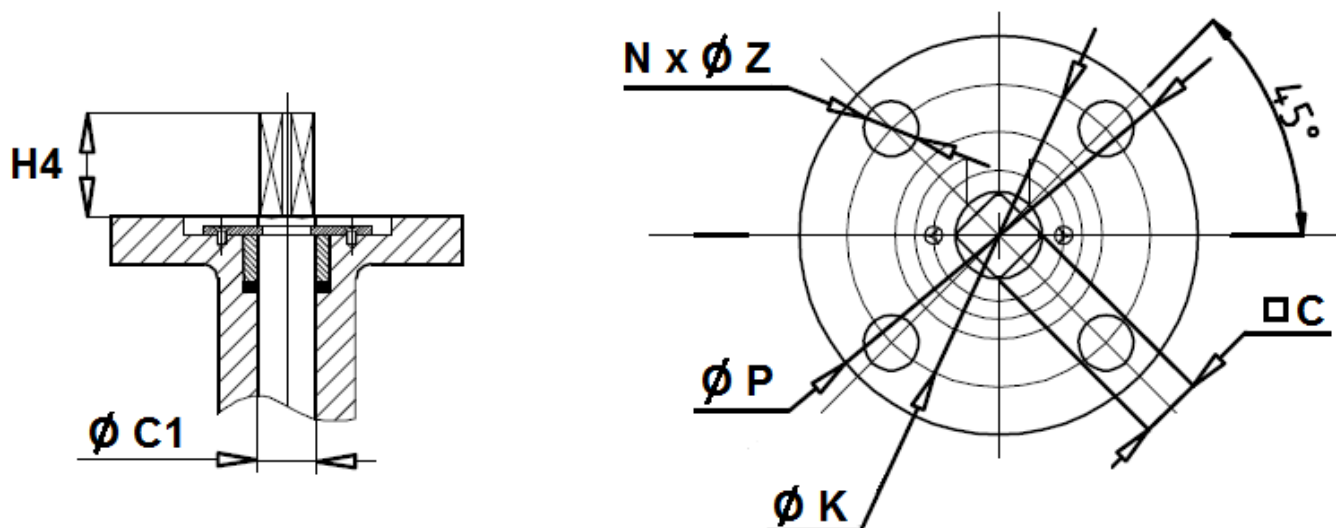

DN	40	50	65	80	100	125	150	200	250	300
H4	43	43	43	43	43	43	43	46	46	46
Ø C1	12.6	12.6	12.6	12.6	15.77	18.92	18.92	22.1	28.45	31.6
C	9	9	9	9	11	14	14	17	22	22
Ø P	90	90	90	90	90	90	90	125	125	125
Ø K	70	70	70	70	70	70	70	102	102	102
ISO	F07	F07	F07	F07	F07	F07	F07	F10	F10	F10
N x Ø Z	4 x 10	4 x 10	4 x 10	4 x 10	4 x 10	4 x 10	4 x 10	4 x 12	4 x 12	4 x 12

DN	350	400	450	500	600
H4	40	50	50	65	65
Ø C1	31.6	37.95	42.86	45.72	53.98
C	22	27	27	36	36
Ø P	125	175	175	175	210
Ø K	102	140	140	140	165
ISO	F10	F14	F14	F14	F16
N x Ø Z	4 x 12	4 x 18	4 x 18	4 x 18	4 x 23

**LUG BUTTERFLY VALVE PERFORMANCE RANGE  
 DUCTILE IRON BODY WITH STAINLESS STEEL DISC AND EPDM HT SEAT**

**GEARBOX SPECIFICATIONS REF.1192:**

DN	32/40 – 80	100	125 – 150	200	250	300	400-500	600
Ref.	1192001	1192002	1192003	1192004	1192005	1192006	-	-
Ratio factor	24 :1	24 :1	24 :1	32 :1	32 :1	50 :1	532 :1	640 :1
Number of turns for closing/opening	6	6	6	8	8	12.5	133	160
Output torque ( Nm )	170	170	170	500	500	1200	2500	4000

**STANDARDS :**

Fabrication according to ISO 9001:2008

Designing according to BS 5155

DIRECTIVE 97/23/CE : CE N° 0035  
 Risk category III module H

Certificate 3.1 on request

Pressure tests according to EN 12266-1, range A

Between flanges according to EN 1092-1 PN10-PN16

ISO 5211 mounting pad

Length according to ISO 5752 short series 20, EN 558 series 20 ( NF 29305 ),BS 5155 Wafer short/medium, DIN 3202 part 3, series K1

**ADVICE :** Our opinion and our advice are not guaranteed and SFERACO shall not be liable for the consequences of damages. The customer must check the right choice of the products with the real service conditions.

**LUG BUTTERFLY VALVE PERFORMANCE RANGE  
DUCTILE IRON BODY WITH STAINLESS STEEL DISC AND EPDM HT SEAT**

**INSTALLATION INSTRUCTIONS**

**GENERAL GUIDELINES :**

Ensure that the valves to be used are appropriate for the conditions of the installation (type of fluid, pressure and temperature).

Be sure to have enough valves to be able to isolate the sections of piping as well as the appropriate equipment for maintenance and repair.

Ensure that the valves to be installed are of correct strength to be able to support the capacity of their usage.

**Installation of all circuits should ensure that their function can be automatically tested on a regular basis (at least two times a year).**

**INSTALLATION INSTRUCTIONS :**

**Before installing the valves, clean and remove any objects from the pipes** (in particular bits of sealing and metal) which could obstruct and block the valves.

**Ensure that both connecting pipes either side of the valve (upstream and downstream) are aligned (if they're not, the valves may not work correctly).**

**Make sure that the two sections of the pipe (upstream and downstream) match, the valve unit will not absorb any gaps. Any distortions in the pipes may affect the tightness of the connection, the working of the valve and can even cause a rupture.** To be sure, place the kit in position to ensure the assembling will work.

**If sections of piping do not have their final support in place, they should be temporarily fixed. This is to avoid unnecessary strain on the valve.**

The valve must be inserted between flanges with disc half opened but the disc must not overpass the valve thickness. Position the bolts to keep centered the valve. Then open fully the valve and tighten the bolts.

**See graph under.**

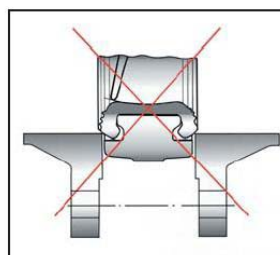
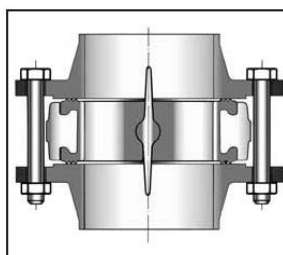
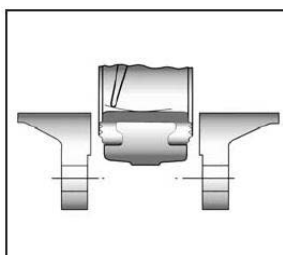

**Half open valve introduction    Complete opened disc valves  
when screw tightening**

Tighten the bolts in cross.

The disc must move easily inside the pipe.

Valves must be opened during cleaning operation.

Tests must be done with a cleaned pipe.

Tests must be done with opened valve. Test pressure must not be higher than the valve specification according to EN 12266-1.

Then open slowly the valve.

**Do not mount butterfly valves with stainless steel pressed collars and turning flanges without strias.**

**And not on flat face flanges without strias ( example : painted cast iron fittings )**



**LUG BUTTERFLY VALVE PERFORMANCE RANGE  
DUCTILE IRON BODY WITH STAINLESS STEEL DISC AND EPDM HT SEAT****MAINTENANCE :**

We recommend to operate fully the valve 1 to 2 times per year.

During maintenance operation, ensure that the pipe isn't under pressure, that there's no fluid in the pipe and that the valve is isolated. If there's a fluid in the pipe, evacuate it. Ensure that there are no risks due to the temperature or the fluid (like acids). If the fluid is corrosive, inert the installation before maintenance operation.