

LUG GAS BUTTERFLY VALVE NF ROBGAZ EXCELLENCE RANGE

armat
spol. s r.o.
MADE OF STAINLESS ...



Reinforced lug for DN200 :



ROB-GAZ



Lloyd's Register

PED 97/23/CE



- Size :** DN 40 to 200 mm
- Ends :** Between PN10/16 flanges (PN10 for DN200)
- Min Temperature :** - 20°C
- Max Temperature :** + 60°C
- Max Pressure :** 5 Bars
- Specifications :** Long neck for isolation
Lug type
Full crossing stem
ISO 5211 mounting pad
- Materials :** Ductile iron EN GJS 500-7 body

*the installation defects and wear defects are not covered by the guarantee

LUG GAS BUTTERFLY VALVE NF ROBGAZ EXCELLENCE RANGE

SPECIFICATIONS :

Long neck for isolation
 ISO 5211 mounting pad
 Lug type (Reinforced lug for DN200)
 Between PN10/16 flanges (PN10 for DN200)
Certificate NF ROBGAZ
 Full crossing stem
 Removable NBR gas seat
 Stainless steel disc up to DN100 included and ductile iron epoxy coated disc +/- 40 µ from DN125 to 200
 9 positions lever with locking device
 Rilsan coated body color RAL 5024 , 250-300 microns thickness

USE :

Fluids : Gas
 Min and max Temperature Ts : - 20°C to + 60°C
 Max Pressure Ps : 5 bars (MOP 5 class)

RANGE :

With lever from DN 40 to DN 200

ENDS :

Between PN10/16 flanges up to DN150 and PN10 for DN200

TORQUE VALUES (in Nm with safety coefficient of 30 % included) at 10 Bars :

DN	40	50	65	80	100	125	150	200
Torque (Nm)	9	11	20	29	47	82	130	210

FLOW COEFFICIENT Kvs (m³ / h) :

DN	40	50	65	80	100	125	150	200
Kvs (m ³ /h)	70	109	200	334	551	901	1427	2383

LUG GAS BUTTERFLY VALVE NF ROBGAZ EXCELLENCE RANGE

HEAD LOSS GRAPH :

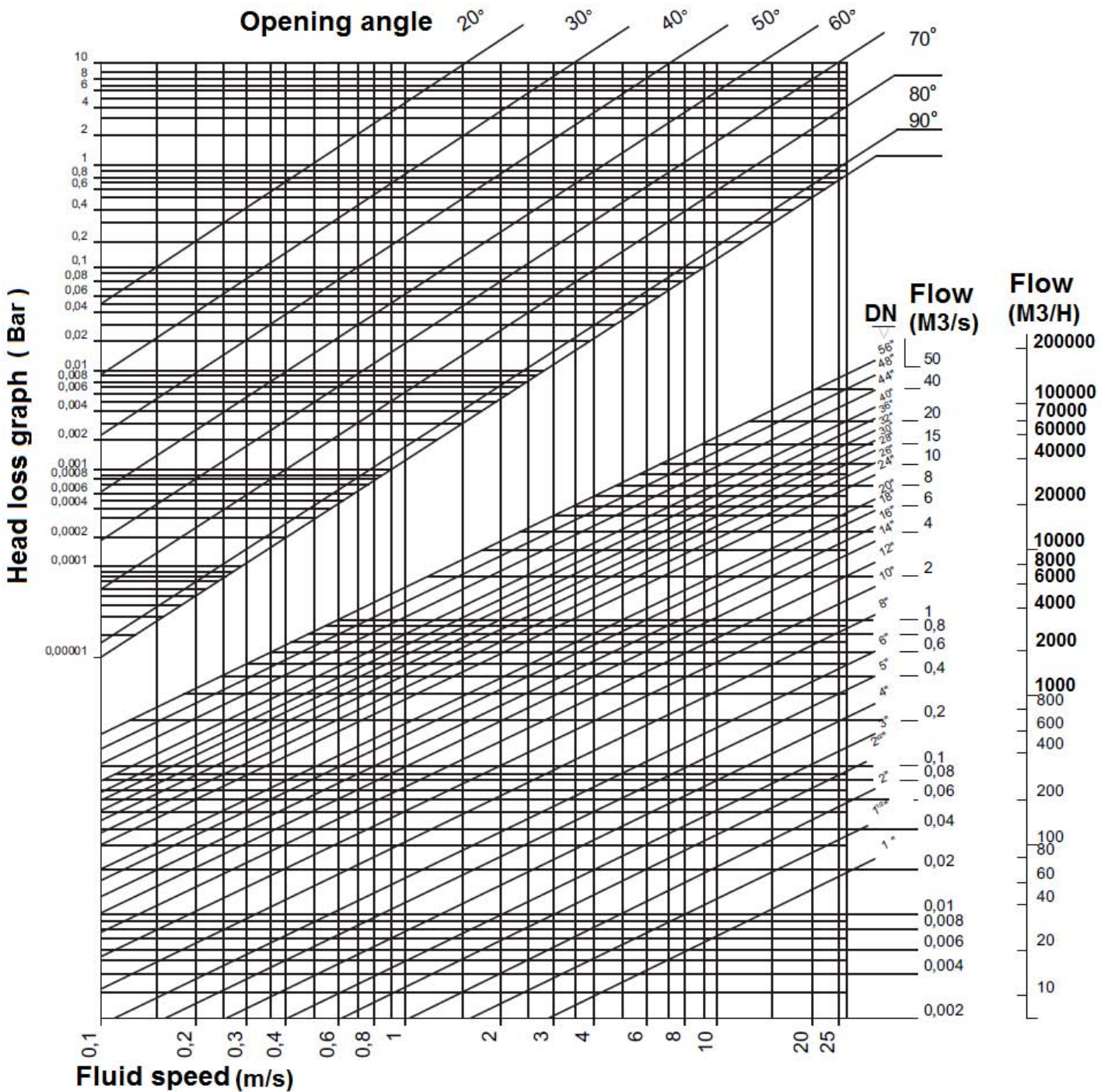

LUG GAS BUTTERFLY VALVE NF ROBGAZ EXCELLENCE RANGE

MATERIALS DN 40 - 200 :

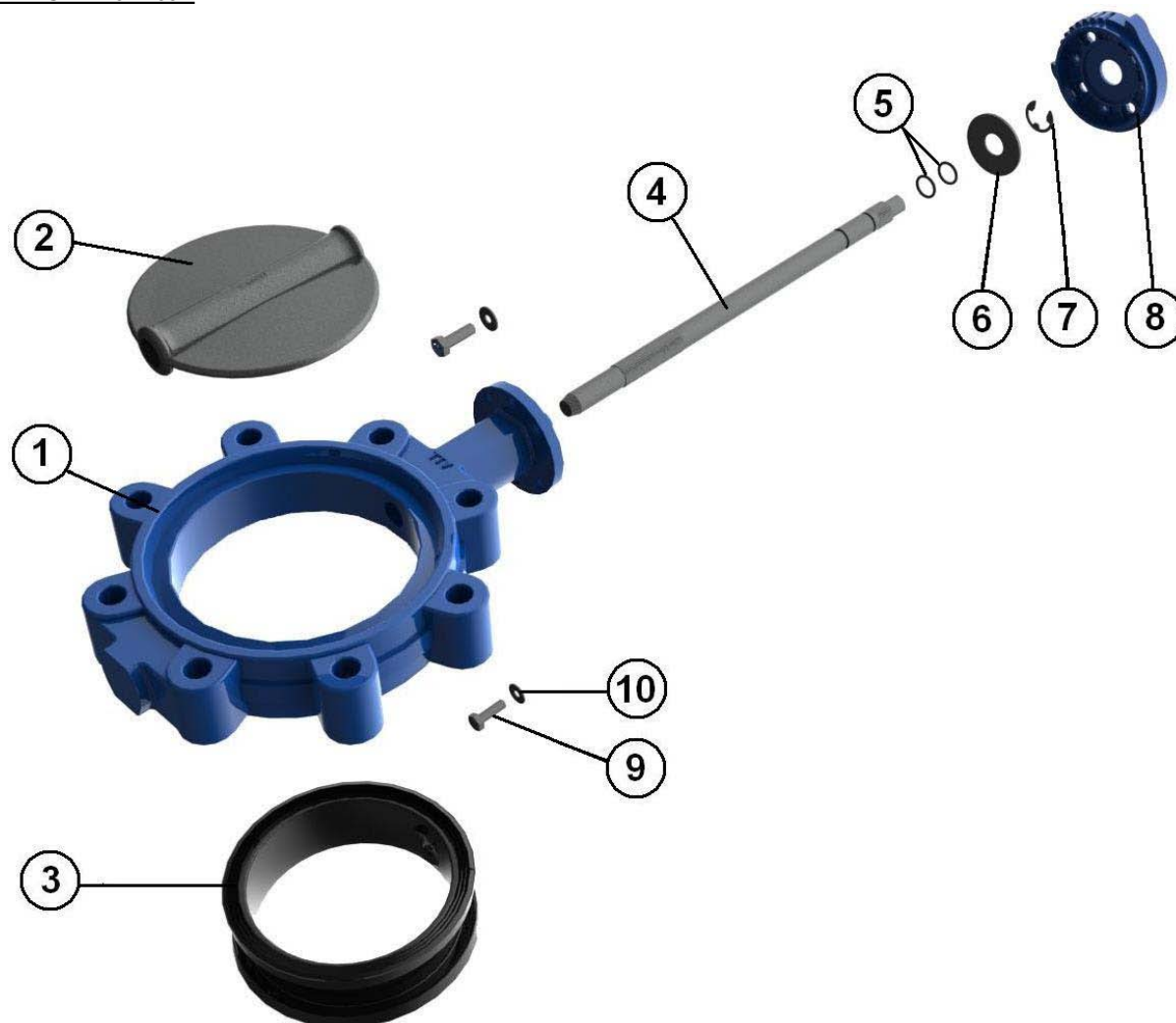

Item	Designation	Materials
1	Body	Ductile iron EN GJS-500-7
2	Disc DN40-100	ASTM A351 CF8M
2	Disc DN125-200	Ductile iron EN GJS 500-7 epoxy coated
3	Seat	NBR for Gas
4	Stem	SS 420
5	O ring	NBR
6	Ring	Steel
7	Circlips	Steel
8	Plate	Aluminium
9	Plate screw	5.6
10	Washer	Steel
	Lever	Aluminium ADC10 with epoxy painting 50µ thickness

LUG GAS BUTTERFLY VALVE NF ROBGAZ EXCELLENCE RANGE

SIZE PN10/16 (in mm) :

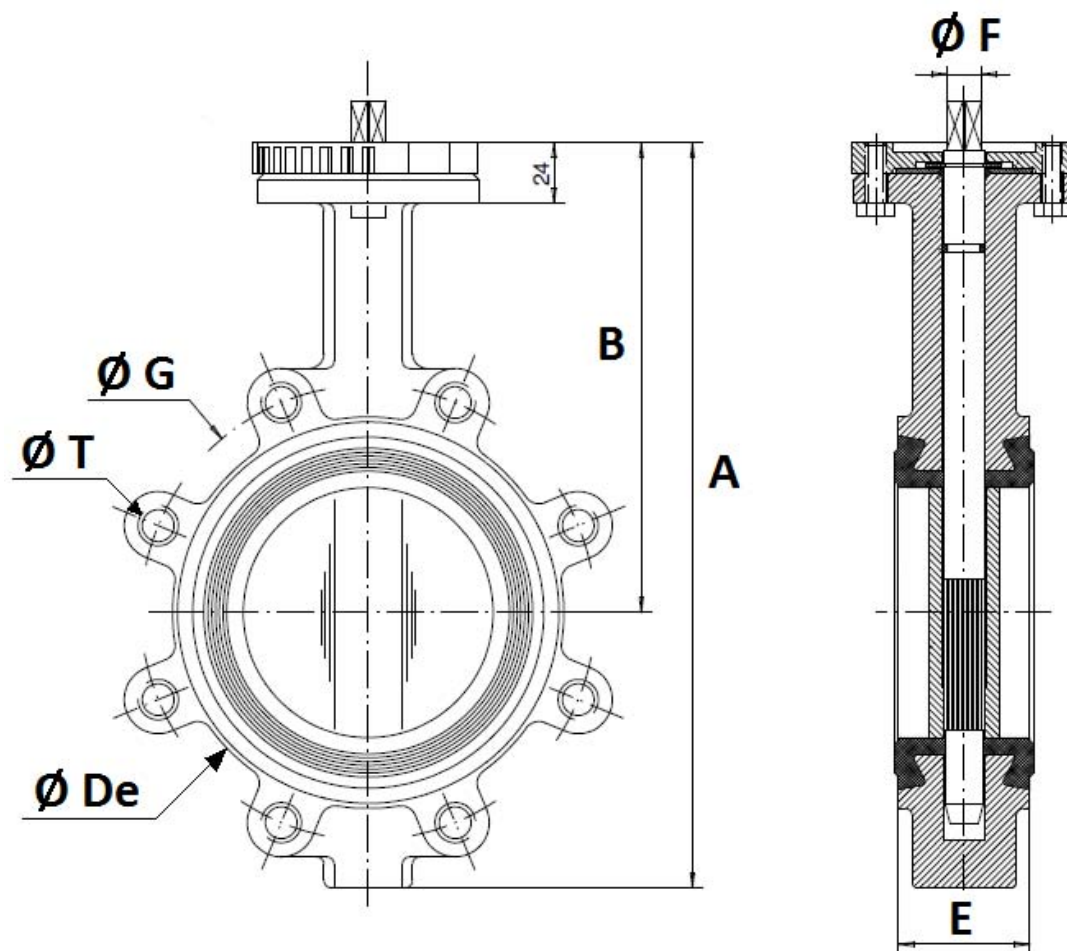

DN	32/40	50	65	80	100	125	150
A	205	226	246	259	295	325	352
B	140	156	161	169	187	206	215
Ø De	83	102	115	136	157	192	220
E	33	43	46	46	52	56	56
Ø F	9.5	9.5	12	14	14	17	17
Ø G	100/110	125	145	160	180	210	240
Ø T	4xM16	4xM16	4xM16	8xM16	8xM16	8xM16	8xM20
Weight (Kg)	2.7	4.1	4.7	6.1	7.9	10.9	11.85

LUG GAS BUTTERFLY VALVE NF ROBGAZ EXCELLENCE RANGE

SIZE PN10 (in mm):

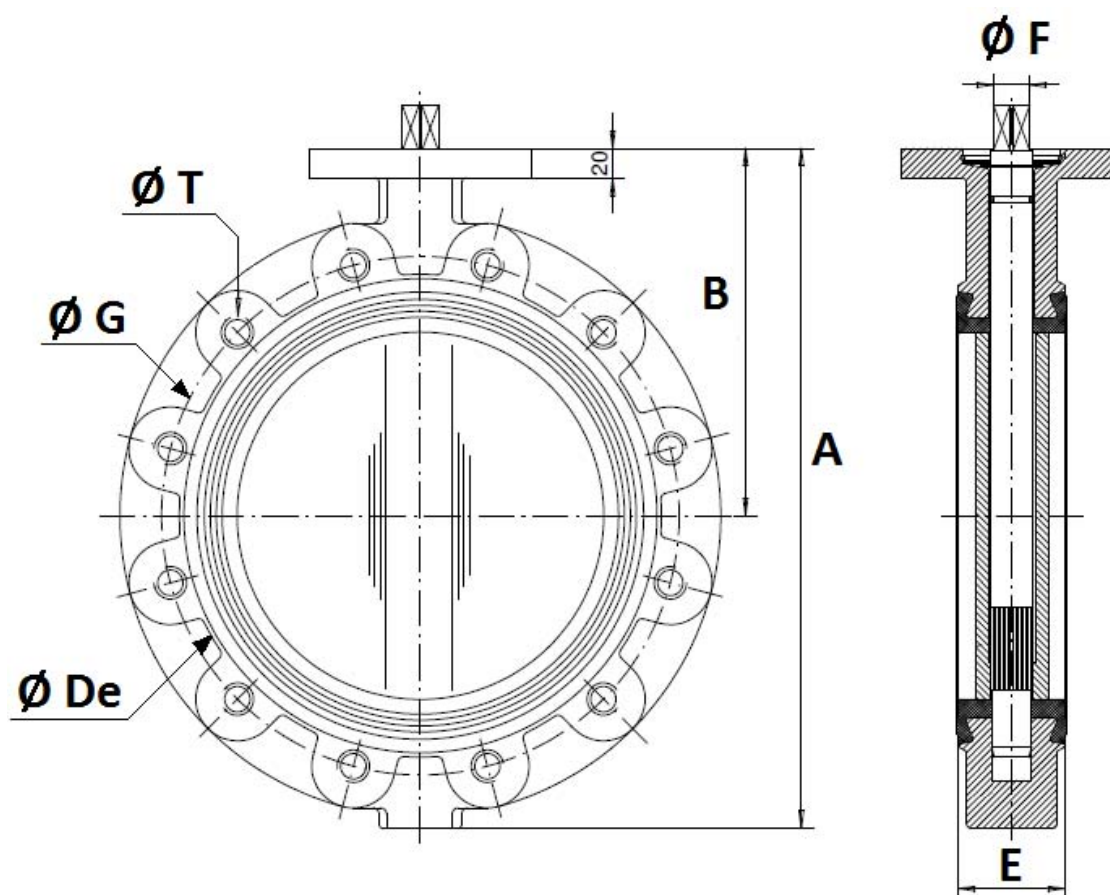

DN	200
A	422
B	255
Ø De	275
E	60
Ø F	21
Ø G	295
Ø T	8xM20
Weight (Kg)	18.5

LUG GAS BUTTERFLY VALVE NF ROBGAZ EXCELLENCE RANGE

LEVERS SIZE (in mm):

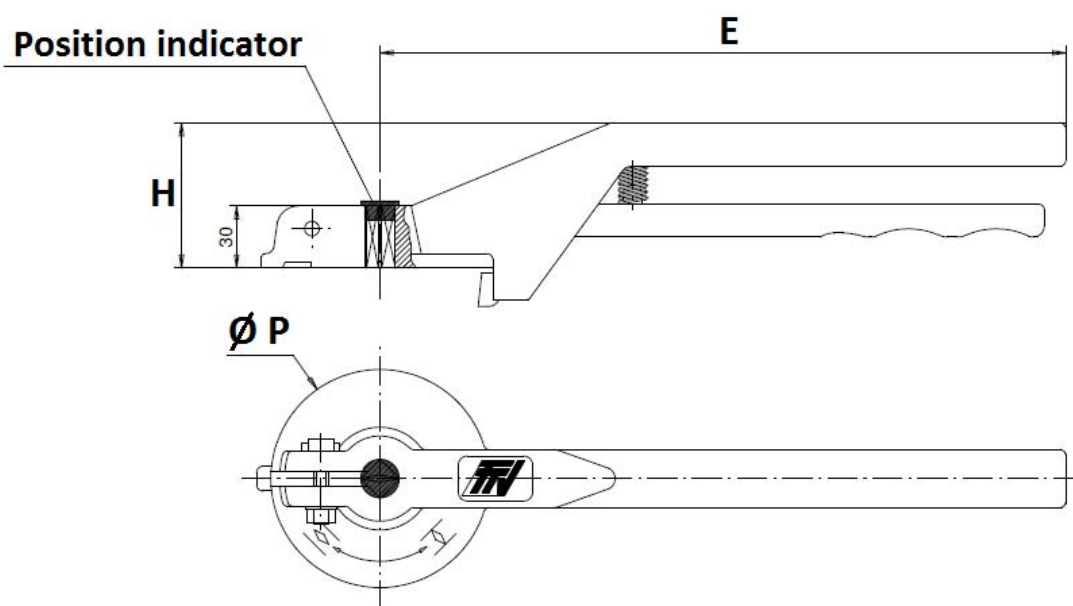

DN	32-100	125-200
E	205	330
H	57	70
Ø P	88	105

LUG GAS BUTTERFLY VALVE NF ROBGAZ EXCELLENCE RANGE

NECK AND DISC SIZE (in mm):

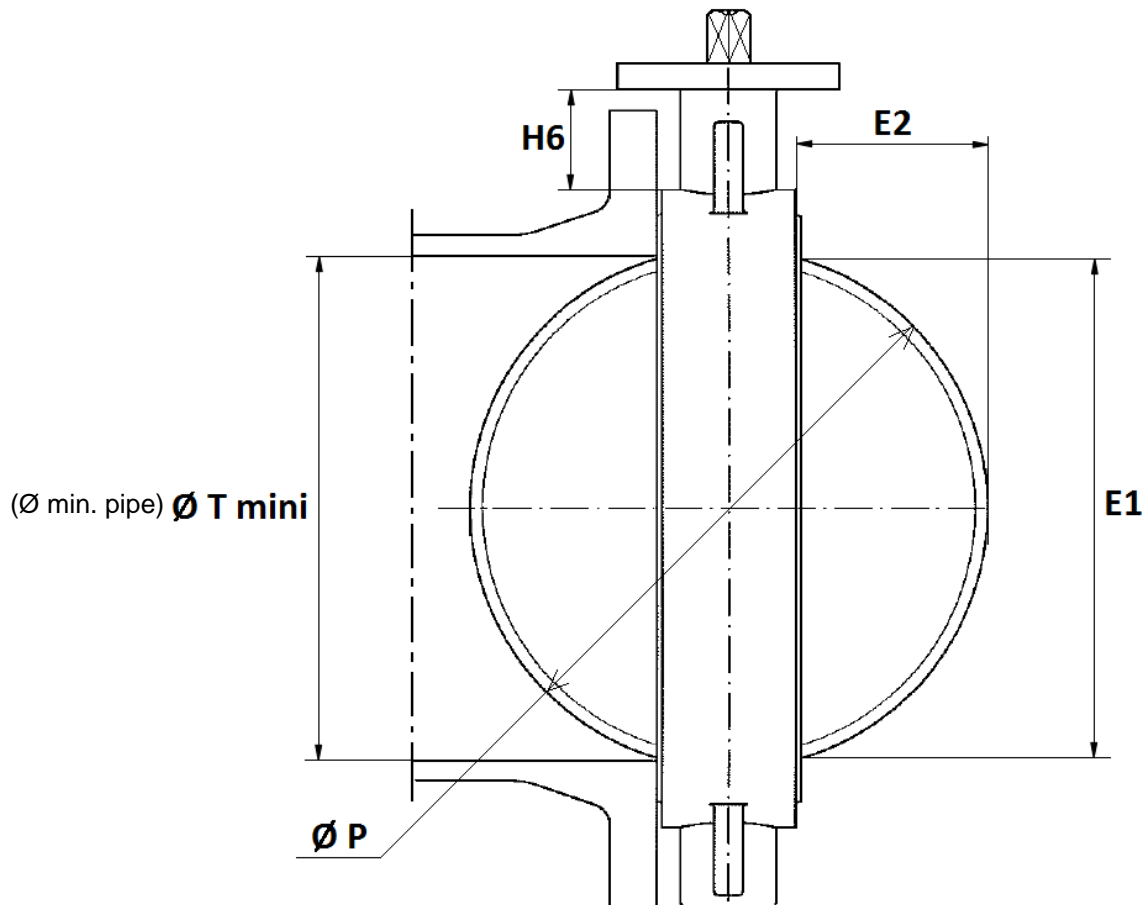

DN	32/40	50	65	80	100	125	150	200
E1	23	24.5	46	65	85	109	136	188
E2	3.5	3.5	9.5	17	24	33.5	45.5	69
H6	76	82	80	80	88	93	89	99
$\varnothing T \text{ mini}$	26	27.5	49	68	88	112	139	191
$\varnothing P$	40	50	65	80	100	123	147	198

LUG GAS BUTTERFLY VALVE NF ROBGAZ EXCELLENCE RANGE

ISO MOUNTING PAD AND STEM SIZE (in mm) :

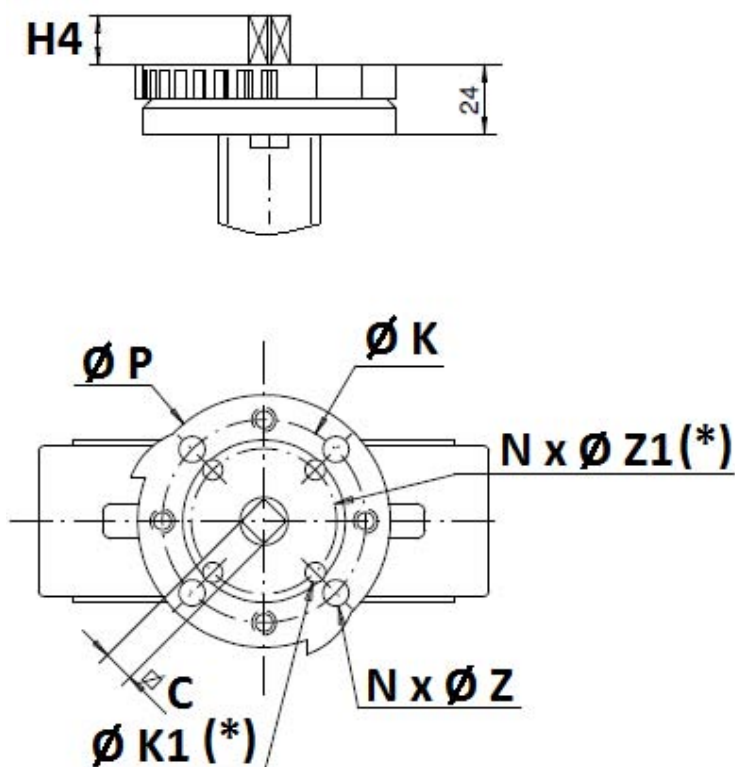

(*) : Only from DN32 to DN100

DN	32/40	50	65	80	100	125	150	200
H4	14	14	16	16	20	20	20	24
C	8	8	9	11	11	14	14	17
Ø K	70	70	70	70	70	70	70	70
ISO	F07	F07	F07	F07	F07	F07	F07	F07
N x Ø Z	4 x 9	4 x 9	4 x 9	4 x 9	4 x 9	4 x 9	4 x 9	4 x 9
Ø K1	50	50	50	50	50	-	-	-
ISO 1	F05	F05	F05	F05	F05	-	-	-
N x Ø Z1	4 x 7	4 x 7	4 x 7	4 x 7	4 x 7	-	-	-

LUG GAS BUTTERFLY VALVE NF ROBGAZ EXCELLENCE RANGE

STANDARDS :

Fabrication according to ISO 9001:2008

DIRECTIVE 97/23/CE : CE N° 0038
Risk Category III module H

Tests according to ISO 5208, rate A

Between ISO PN10/16 flanges according to EN 1092-1

ISO 5211 mounting pad

Length according to ISO 5752 short series 20, EN 558 series 20 (NF 29305), BS 5155 Wafer short/medium, DIN 3202 part 3, series K1

ATEX Group II Category 2 G/2D Zone 1 & 21 Zone 2 & 22 (optional marking)

Certificate NF ROBGAZ N° ROB 064-R4 according to NF EN 13774 & NF EN 549

ADVICE : Our opinion and our advice are not guaranteed and SFERACO shall not be liable for the consequences of damages. The customer must check the right choice of the products with the real service conditions.

INSTALLATION INSTRUCTIONS

GENERAL GUIDELINES :

Ensure that the valves to be used are appropriate for the conditions of the installation (type of fluid, pressure and temperature).

Be sure to have enough valves to be able to isolate the sections of piping as well as the appropriate equipment for maintenance and repair.

Ensure that the valves to be installed are of correct strength to be able to support the capacity of their usage.

Installation of all circuits should ensure that their function can be automatically tested on a regular basis (at least two times a year).

INSTALLATION INSTRUCTIONS :

Before installing the valves, clean and remove any objects from the pipes (in particular bits of sealing and metal) which could obstruct and block the valves.

Ensure that both connecting pipes either side of the valve (upstream and downstream) are aligned (if they're not, the valves may not work correctly).

Make sure that the two sections of the pipe (upstream and downstream) match, the valve unit will not absorb any gaps. Any distortions in the pipes may affect the tightness of the connection, the working of the valve and can even cause a rupture. To be sure, place the kit in position to ensure the assembling will work.

LUG GAS BUTTERFLY VALVE NF ROBGAZ EXCELLENCE RANGE

INSTALLATION INSTRUCTIONS (SUITE):

If sections of piping do not have their final support in place, they should be temporarily fixed. This is to avoid unnecessary strain on the valve.

The valve must be inserted between flanges with disc half opened but the disc must not overpass the valve thickness. Position the bolts to keep centered the valve. Then open fully the valve and tighten the bolts.

See graph under.

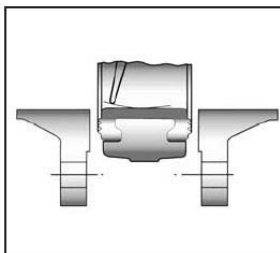

Half open valve introduction

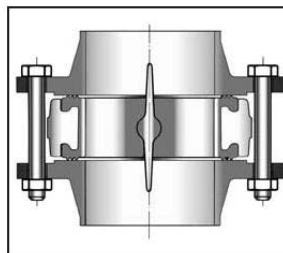

Complete opened disc valves when screw tightening

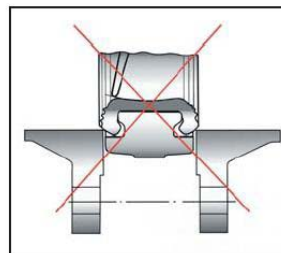

Tighten the bolts in cross.

The disc must move easily inside the pipe.

Valves must be opened during cleaning operation.

Tests must be done with a cleaned pipe.

Tests must be done with opened valve. Test pressure must not be higher than the valve specification according to ISO 5208.

Then open slowly the valve.

Do not mount butterfly valves with stainless steel pressed collars and turning flanges without strias.

And not on flat face flanges without strias (example : painted cast iron fittings)

MAINTENANCE :

We recommend to operate fully the valve 1 to 2 times per year.

During maintenance operation, ensure that the pipe isn't under pressure, that there's no fluid in the pipe and that the valve is isolated. If there's a fluid in the pipe , evacuate it. Ensure that there are no risks due to the temperature or the fluid (like acids). If the fluid is corrosive , inert the installation before maintenance operation.