

FIRE SAFE 3 PIECES BALL VALVE PN 100

armat
spol. s r.o.
MADE OF STAINLESS ...



**Lloyd's
Register**

PED 97/23/CE



**FIRE SAFE
API 607**



Size : DN 8 to 50 mm
Ends : Threaded BSP or NPT , S.W. or B.W.
Min Temperature : -30°C in SS and -20°C in carbon steel
Max Temperature : + 220°C
Max Pressure : 100 to 140 Bars
Specifications : Antistatic device
ISO 5211 mounting pad
Anti blow-out stem
Fully encapsulated bolts
Fire safe
Atex

Materials : Carbon steel or Stainless steel

FIRE SAFE 3 PIECES BALL VALVE PN 100

SPECIFICATIONS :

Full bore
 Anti blow-out stem
 Special gland pack with elastic washer
 Antistatic device from DN8 to 10, double antistatic device (ball between body-stem and ball-stem) from DN15 to 50
 Fire safe according to API 607-4
 Locking device
 Handwheel and stem extension (optional)
 ISO 5211 mounting pad
 Fully encapsulated bolts
 Pressure class 600 lbs
 On request PEEK seat(optional) for high temperature

USE :

Chemical and pharmaceutical industries, petrochemical industries, hydraulic installation, compressed air
 Steam : 18 bars maximum with PTFE filled with 25% carbon seat
 Steam : 30 bars maximum with PEEK seat
 Vacuum : 10⁻² torr
 Min and max Temperatures Ts : -30°C to + 220°C for stainless steel valve with PTFE filled with 25% carbon seat type **Ref. 703**
 Min and max Temperatures Ts : -20°C to + 220°C for carbon steel valve with PTFE filled with 25% carbon seat type **Ref. 702**
 Min and max Temperatures Ts : -10°C to + 260°C for valve with PEEK seat (optional)
 Max Pressure Ps : 100 to 140 bars (see graph)

FLOW COEFFICIENT Kvs (M3 / h) :

DN	1/4"	3/8"	1/2"	3/4"	1"	1"1/4	1"1/2	2"
Kvs (m3/h)	13	13.4	31.3	57.86	94.25	157.9	227.9	414.8

RANGE :

Carbon steel Ref. **702** DN 8 to DN 50
 Stainless steel Ref. **703** DN 8 to DN 50

ENDS :

Female / female threaded BSP
 Female / female threaded NPT
 Welding S.W.
 Welding B.W.

OPTIONS :

SS 304 handwheel **Ref. 9830440-9830475**

SS 304 stem extension **Ref. 9830471-9830474**

PEEK gasket kits (including Grafoil body gasket and packing, PTFE filled 15% glass fiber stem gasket + Grafoil and PEEK seat)
Ref. 9804380-9804386

FIRE SAFE 3 PIECES BALL VALVE PN 100

PRESSURE / TEMPERATURE GRAPH FOR CARBON STEEL VALVES REF.702 (WITH PTFE FILLED WITH CARBON SEAT) :

**PRESSURE
(Bar)**

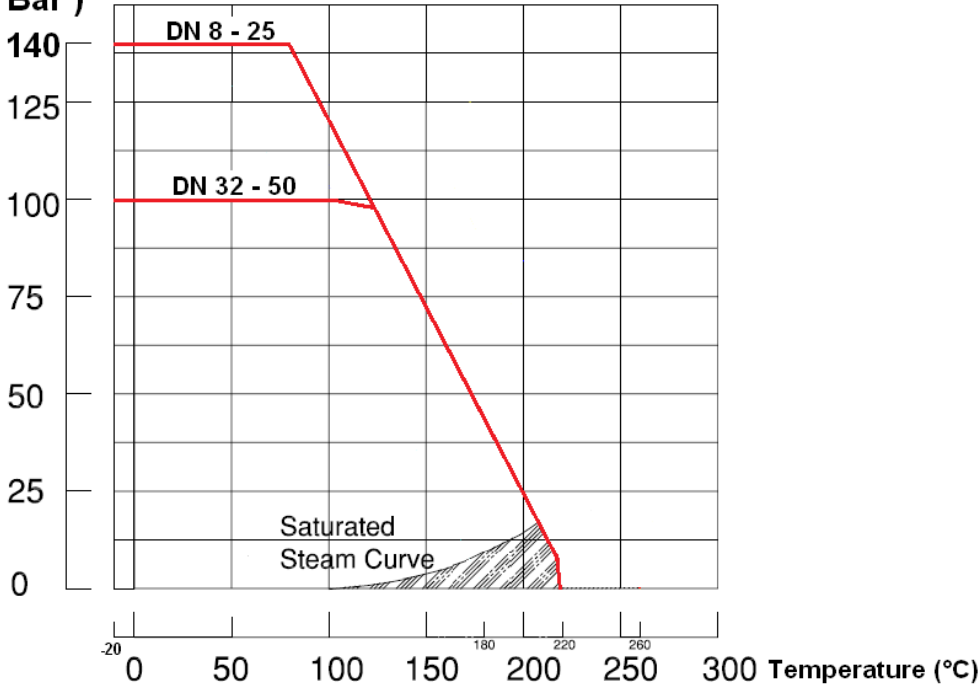

PRESSURE / TEMPERATURE GRAPH FOR STAINLESS STEEL VALVES REF.703 (WITH PTFE FILLED WITH CARBON SEAT) :

**PRESSURE
(Bar)**

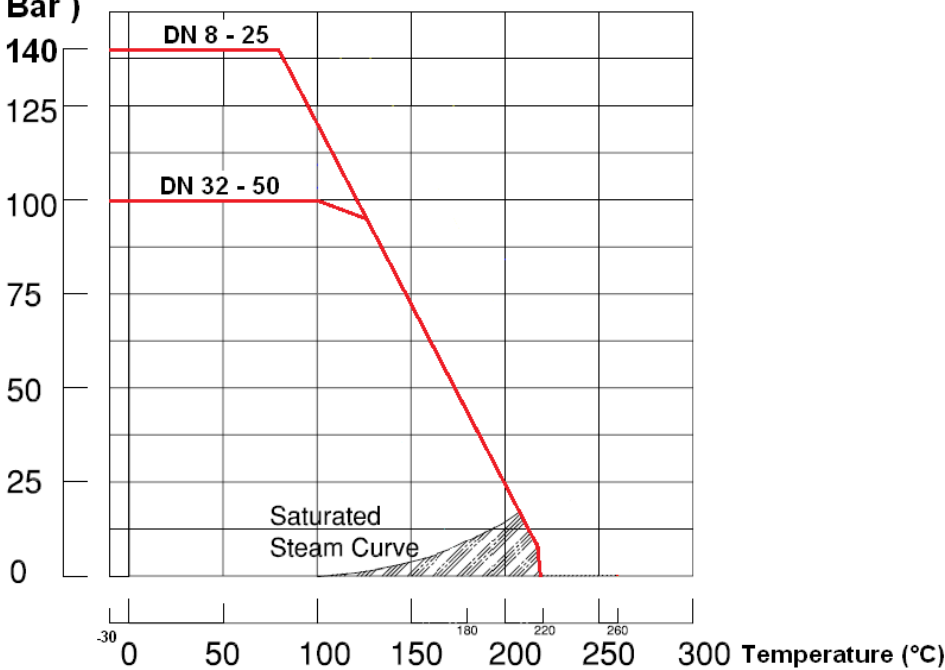

FIRE SAFE 3 PIECES BALL VALVE PN 100

PRESSURE / TEMPERATURE GRAPH FOR CARBON STEEL VALVES REF.702 WITH OPTIONAL PEEK SEAT :

PRESSURE

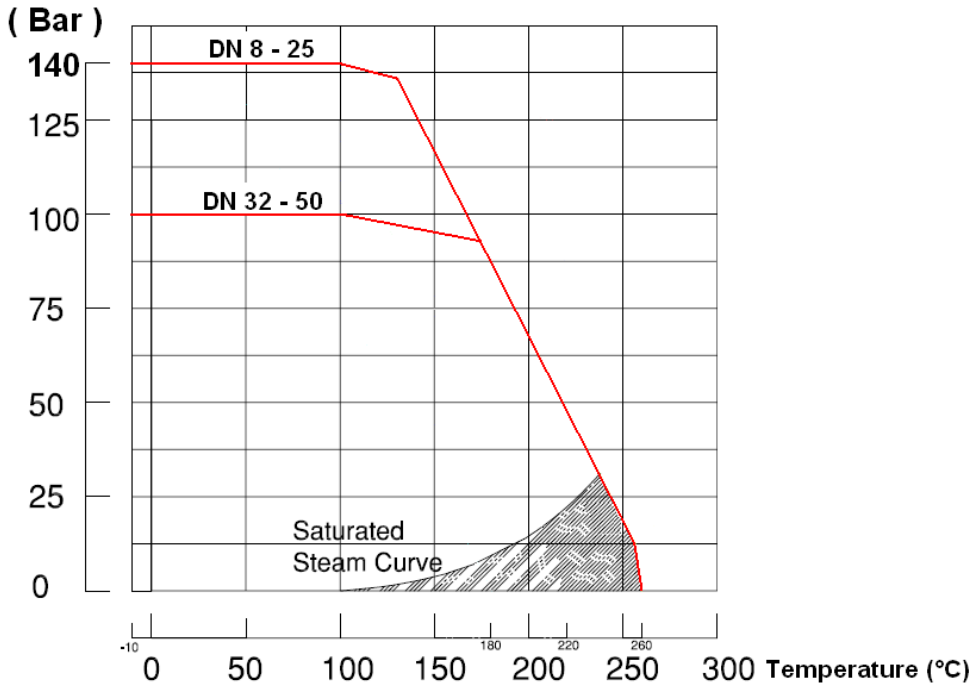

PRESSURE / TEMPERATURE GRAPH FOR STAINLESS STEEL VALVES REF.703 WITH OPTIONAL PEEK SEAT :

PRESSURE

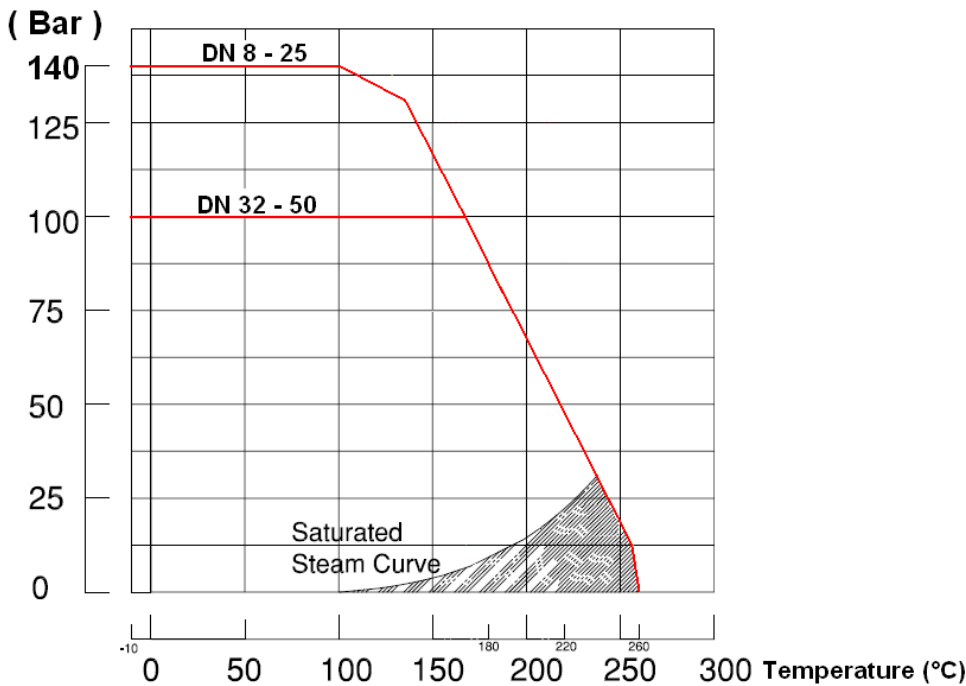

FIRE SAFE 3 PIECES BALL VALVE PN 100

MATERIALS :

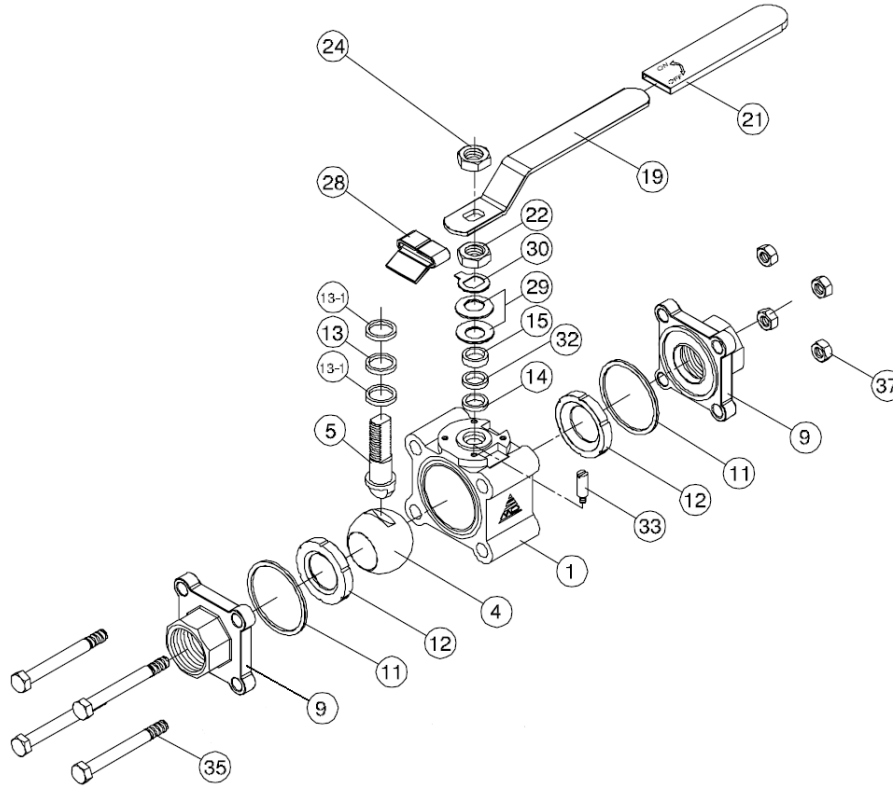

(* : included in gaskets kit)

Item	Designation	Materials 702	Materials 703
1	Body	ASTM A216 WCB	ASTM A351 CF8M
4	Ball	ASTM A351 CF8M	
5	Stem	AISI 316	
9	Ends	ASTM A216 WCB	ASTM A351 CF8M
11*	Body gasket	Graphite	
12*	Seat	PTFE filled with 25% carbon	
13*	Thrust washer	Graphite	
13-1*	Thrust washer	PTFE filled with 15% Glass fiber	
14	Packing	Graphite	
15	Gland bush	AISI 304	
19	Handle	AISI 304	
21	Handle cover	Plastic	
22	Packing nut	AISI 304	
24	Handle nut	AISI 304	
28	Locking device	AISI 304	
29	Elastic washer	AISI 301	
30	Tab washer	AISI 304	
32*	Packing follower	PTFE filled with 15% Glass fiber	
33	Stop pin	AISI 304	
35	Body bolt	AISI 304	
37	Bolt nut	AISI 304	

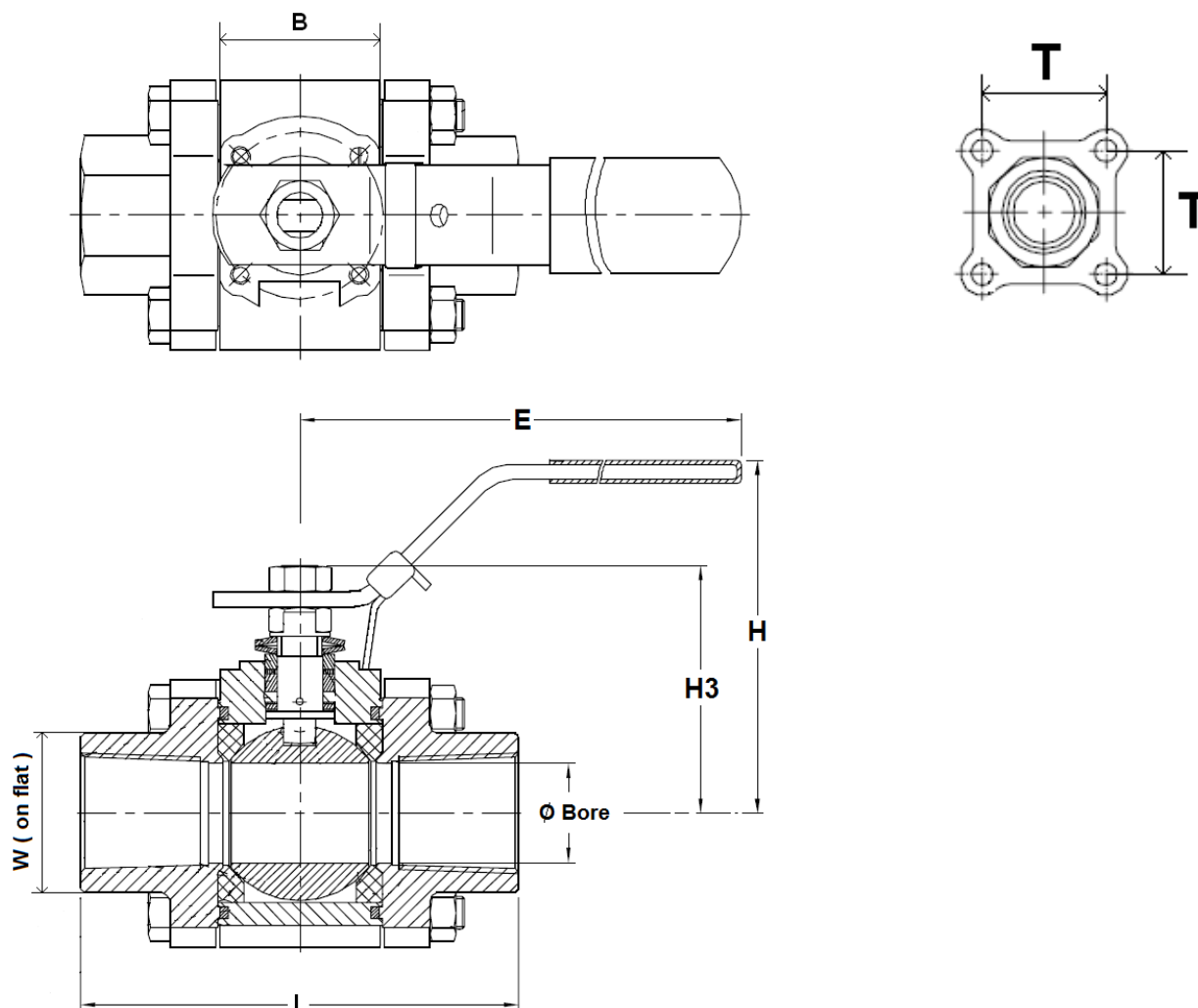
FIRE SAFE 3 PIECES BALL VALVE PN 100
SIZE THREADED TYPES (in mm) :

Ref.	DN	1/4"	3/8"	1/2"	3/4"	1"	1"1/4"	1"1/2"	2"
7020 / 7030 Threaded	Ø Bore	10	10	15	20	25	32	38	50
	L	64,8	64,8	72,5	85,4	105,3	111	127,3	146
	B	20,5	20,5	24,5	31,4	41,3	48,4	56,3	72
	E	132,8	132,8	132,8	132,8	171,8	171,8	204,2	211
	H	63,3	63,3	68	74,4	81,8	86,8	97,4	130
	H3	37	37	45,3	50,4	61,3	66	79	99,4
	T	32	32	38,2	44,3	50	57,2	66,6	82
	W (on flat)	29,5	29,5	30	36	44,5	54	60	73
	Weight (Kg)	0,70	0,70	0,85	1,37	2	2,78	4,08	6,80

FIRE SAFE 3 PIECES BALL VALVE PN 100

SIZE WELDING B.W. TYPES (in mm) :

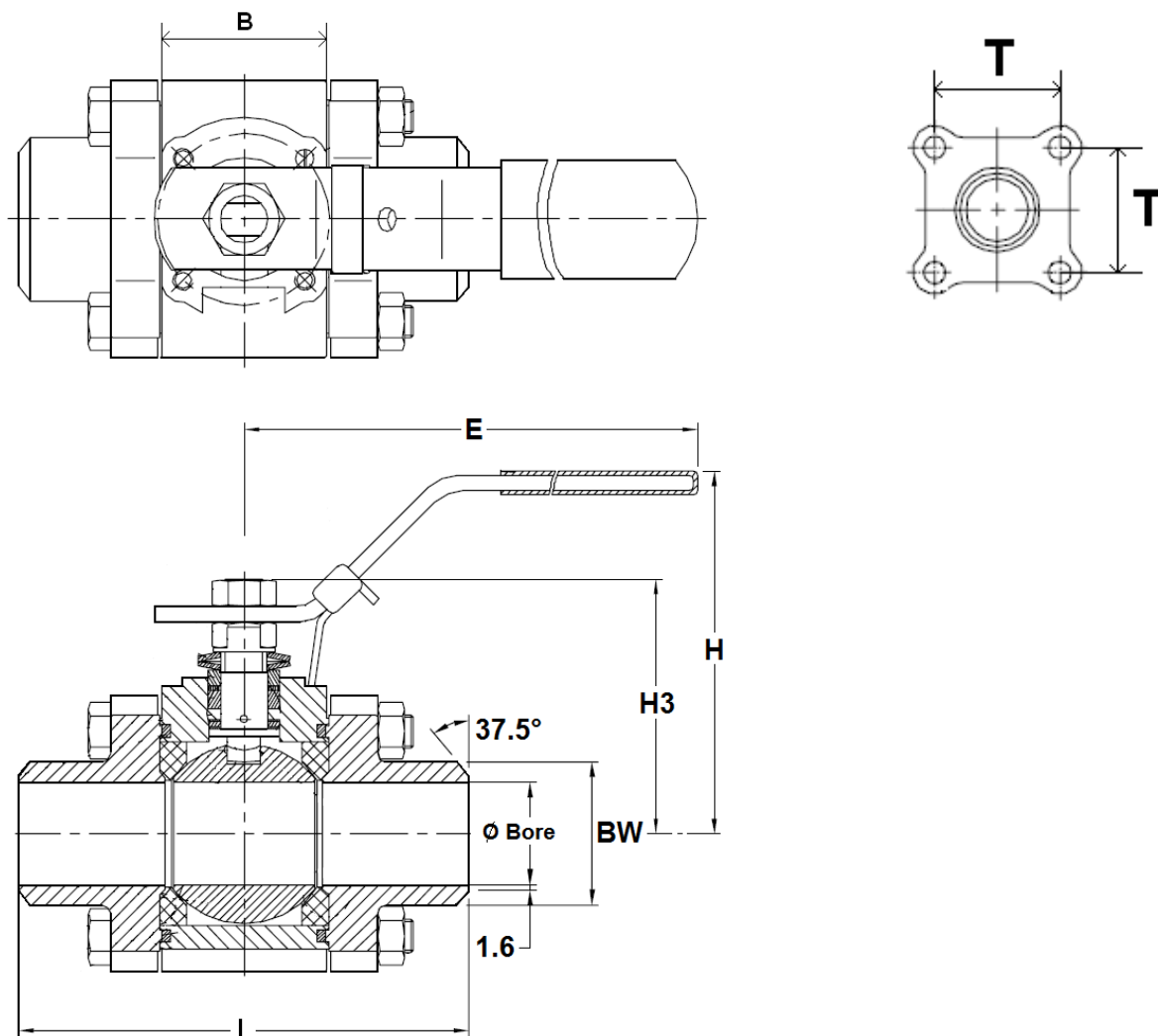

Ref.	DN	8	10	15	20	25	32	40	50
7021 / 7031 Butt Welding	Ø Bore	9,2	10	15	20	25	32	38	50
	L	64,8	64,8	74.9	90	109.9	115	129.5	146
	B	20.5	20.5	24.5	31.4	41.3	48.4	56.3	72
	E	132.8	132.8	132.8	132.8	171.8	171.8	204.2	211
	H	63.3	63.3	68	74.4	81.8	86.8	97.4	130
	H3	37	37	45.3	50.4	61.3	66	79	99,4
	T	32	32	38.2	44.3	50	57.2	66.6	82
	Ø BW	17.7	17.7	21.8	27.2	34.6	42,7	48.9	60.5
	Weight (Kg)	0,63	0.64	0.81	1.30	1.97	2.70	4,08	6.60

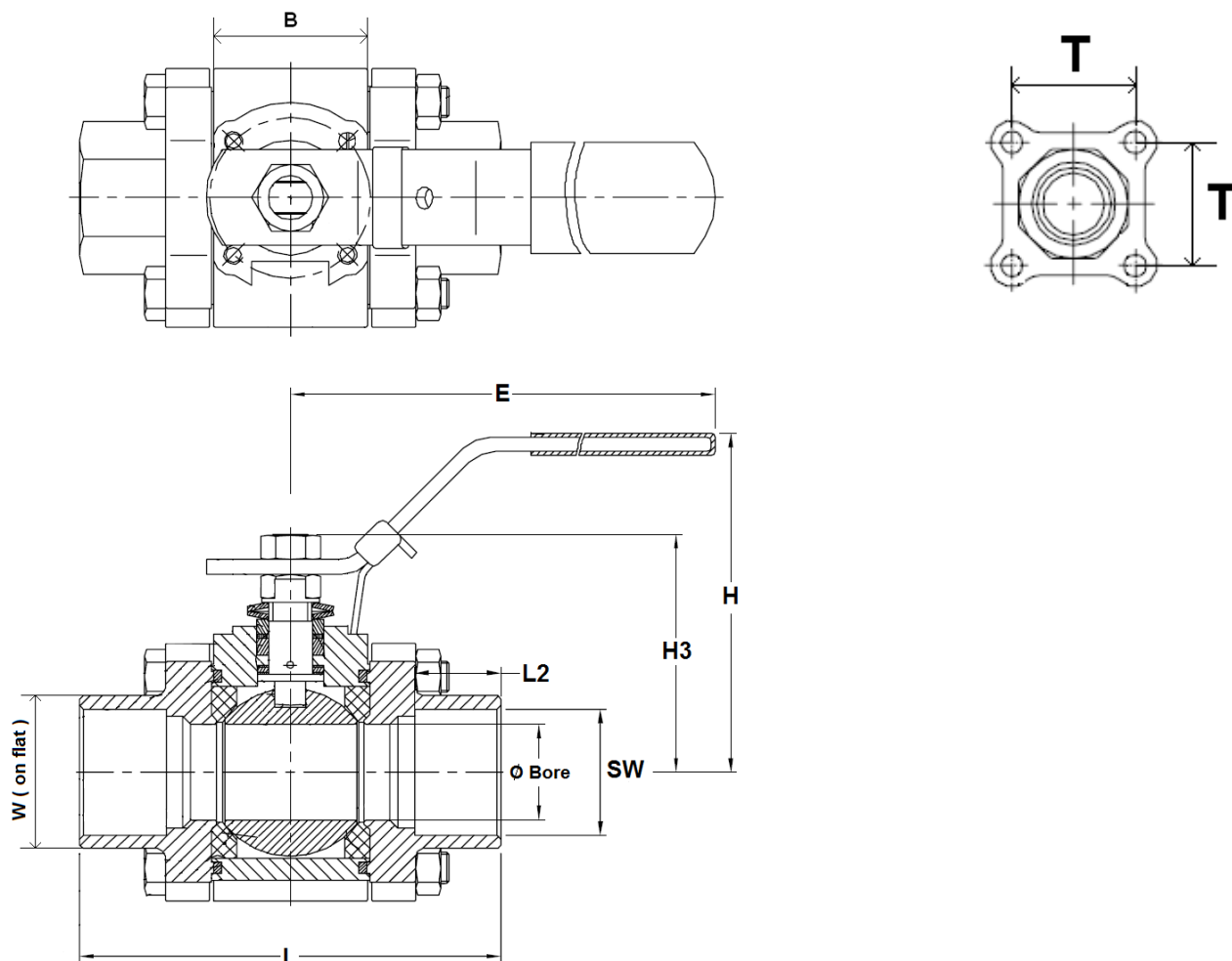
FIRE SAFE 3 PIECES BALL VALVE PN 100
SIZE WELDING S.W. TYPES (in mm) :

Ref.	DN	8	10	15	20	25	32	40	50
7022 / 7032 Socket Weld.	Ø Bore	10	10	15	20	25	32	38	50
	L	64,8	64,8	72,5	85,4	105,3	111	127,3	146
	B	20.5	20.5	24.5	31.4	41.3	48.4	56.3	72
	L2	10	10	10	13	13	13	13	16
	E	132.8	132.8	132.8	132.8	171.8	171.8	204.2	211
	H	63.3	63.3	68	74.4	81.8	86.8	97.4	130
	H3	37	37	45.3	50.4	61.3	66	79	99,4
	T	32	32	38.2	44.3	50	57.2	66.6	82
	W (on flat)	29,5	29,5	30	36	44,5	54	60	73
	Ø SW	14.1	17,6	21.7	27,3	33,9	42,8	48.7	61.3
Weight (Kg)	0,71	0.69	0.83	1.40	2	2,78	4,08	6.80	

FIRE SAFE 3 PIECES BALL VALVE PN 100

ISO 5211 MOUNTING PAD AND STEM SIZE (in mm) :

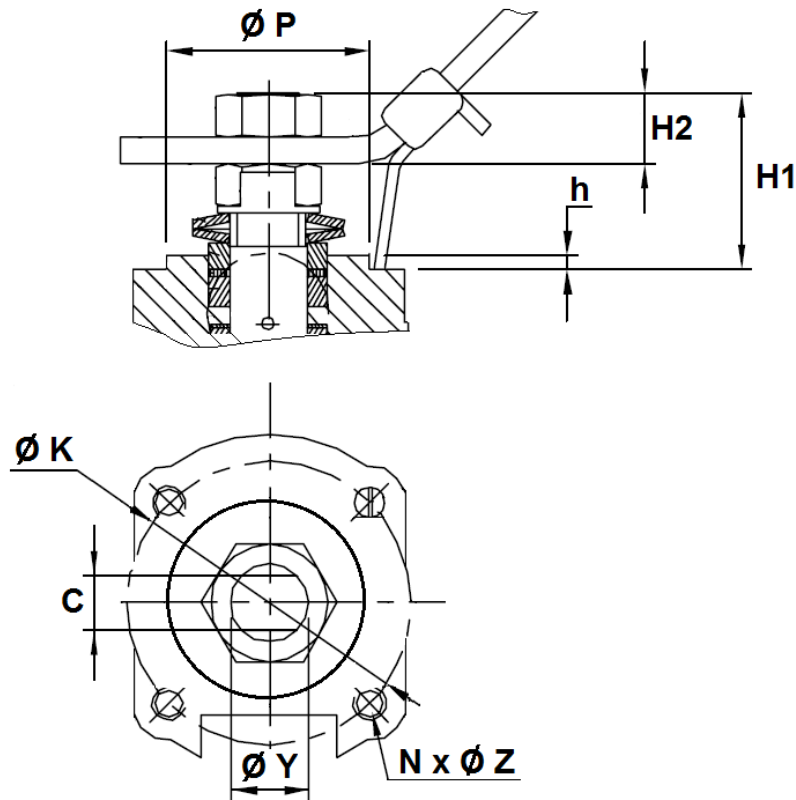

Ref.	DN	1/4"	3/8"	1/2"	3/4"	1"	1"1/4"	1"1/2"	2"
702 / 703	H1	7.2	7.2	16.3	17.4	25.3	26	31.7	28.5
	H2	5.9	5.9	9.3	8.2	11.95	11.65	15	15.5
	h	0,5	0,5	2	2	2	2	2,2	1,5
	C	6,5	6,5	6,5	6,5	8	8	9,7	12
	Ø Y	9,5	9,5	9,5	9,5	11,1	11,1	14,3	19
	Ø P	25	25	25	25	30	30	35	55
	Ø K	36	36	36	36	42	42	50	70
	ISO	F03	F03	F03	F03	F04	F04	F05	F07
	N x Ø Z	4x M5	4x M5	4x M5	4x M5	4x M5	4x M5	4 x M6	4 x M8

FIRE SAFE 3 PIECES BALL VALVE PN 100

SS 304 HANDWHEEL SIZE (in mm) :

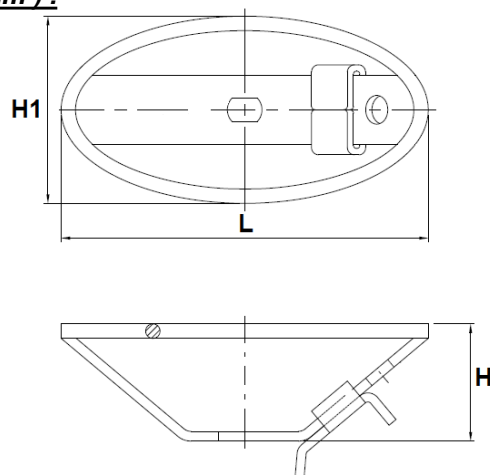

DN	1/4"	3/8"	1/2"	3/4"	1"	1"1/4	1"1/2	2"
L	102	102	116	116	130	130	147	194
H	32.5	32.5	35	35	40	40	43	51
H1	52	52	62	62	82	82	87	98
Weight (Kg)	0.106	0.106	0.119	0.119	0.176	0.176	0.22	0.34
Ref.	9830440	9830440	9830441	9830441	9830442	9830442	9830443	9830475

SS304 STEM EXTENTION SIZE (in mm) :

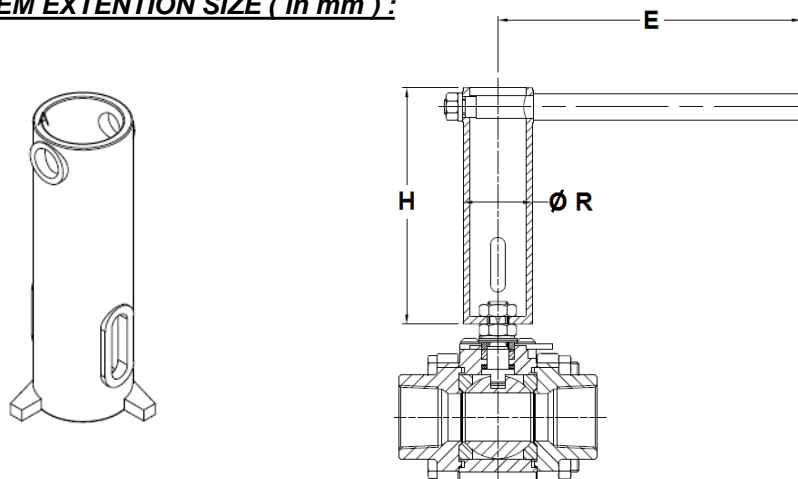

DN	1/2"	3/4"	1"	1"1/4	1"1/2	2"
H	125.5	125.5	125.5	125.5	127.5	127.5
E	126.5	126.5	161	161	194	198.5
Ø R	31	31	37	37	43	52
Ref.	9830471	9830471	9830472	9830472	9830473	9830474

FIRE SAFE 3 PIECES BALL VALVE PN 100

TORQUE VALUES (in Nm without safety coefficient) :

DN	1/4"	3/8"	1/2"	3/4"	1"	1"1/4	1"1/2	2"
Pressure (bar)								
17	7	7	8	10	13	22	29	41
34	7	7	8	10	14	23	30	51
69	7	7	8	11	17	29	39	84
103	7	7	9	14	18	34	46	105
138	9	9	11	15	20			

BOLT TIGHTENING TABLE (in Nm) :

DN	1/4"	3/8"	1/2"	3/4"	1"	1"1/4	1"1/2	2"
Torque (Nm)	10,8	10,8	14,7	17,6	22,5	24,5	41,2	45,1

STANDARDS :

Fabrication according to ISO 9001 : 2008

DIRECTIVE 97/23/CE : CE N° 0038
 Risk category III module H

Construction according to EN 12516-1 Class 600

Designing according to ASME B16.34

Pressure tests according to EN12266-1, rate A

Fire safe according to API 607 4th (only for valves with PTFE filled with 25% carbon seats)

Threaded cylindrical BSPP ends according to ISO 228-1

Threaded NPT ends according to ANSI B1.20.1

S.W. ends according to ASME B16.11 Schedule 40

B.W. ends according to ASME B36.10 Schedule 40

ISO 5211 mounting pad

ATEX Group II Category 2 G/2D Zone 1 & 21 Zone 2 & 22 (optional marking)

ADVICE : Our opinion and our advice are not guaranteed and SFERACO shall not be liable for the consequences of damages.
 The customer must check the right choice of the products with the real service conditions.

FIRE SAFE 3 PIECES BALL VALVE PN 100

INSTALLATION AND MAINTENANCE

BEFORE INSTALLATION :

Pipe-line must be cleaned and free from residual of weldings, rubbish, shaving and every kind of extraneous materials.
 Pipe-line must be perfectly aligned and their support properly dimensioned so that there's no external constraint.

Check to use a produce compatible to the services conditions for the sealing of the threaded types.
 To tighten the ends, use the appropriate tool.
 Use the right bolt tightening so that the ends won't be damaged.

The welding of the ends for the SW and the BW types, must be done with the central part removed.
 A gauge can be used to have the good length and alignment between the ends.

INSTALLATION OF THE CENTRAL PART

During the installation of the central part, tighten bolts according to the table below. Tighten bolts in cross.

BOLT TIGHTENING TABLE (in Nm) :

DN	1/4"	3/8"	1/2"	3/4"	1"	1"1/4	1"1/2	2"
Torque (Nm)	10,8	10,8	14,7	17,6	22,5	24,5	41,2	45,1

CLEANING AND TESTS

Keep closed the valves during the cleaning operation so that there's no impurities between the ball and the body.

Tests under pressure must be done with a cleaned pipe-line.

Open partially the valve for tests. Pressure test do not exceed the valve specifications according to EN 12266-1.

MAINTENANCE

It's recommended to operate the valve twice (open and close) 1 to 2 times per year.

When intervention on the valve, be sure there's no pressure in the pipe-line, there's no fluid in it, and that it is isolated.
 The temperature must be low enough to operate without risks.
 If there's a corrosive fluid, inert installation before intervention.

When the valve is under pressure :
 If there's a leakage between the body and the ends, tighten bolts according to the above table

If there's a leakage at the packing, tighten it slightly so that the leakage disappears.

MAINTENANCE OPERATION IN WORKSHOP

REPLACEMENT OF SEAT GASKETS AND PACKING.

The central part must be removed.

Turn the ball at 45° and removed the seat gaskets.

Operate the valve in closed position to removed the ball. Verify the surface of the ball has no impacts and no scores.

If there are important scores or impacts, replace the ball.

Clean inside the body valve and remove the impurities.

To replace the packing, remove the handle, unscrew the gland nut, extract the stem by the inside of the valve.

Clean the packing seat.

Reassemble thrust washer on stem, introduce stem by the inside of the valve, reassemble packing with packing nut, reassemble hand washer, hand nut and the handle.

Turn stem in closed position and insert the ball.

Then turn the ball in opened position and reassemble the seat.

Place the valve on the installation, tighten bolts according to the above table.

Then proceed to the tests in the same way that the first installation.