

**WAFER BALL VALVE ADLER TYPES FA1/FA2/FB1/FB2**



**Size :** DN 15 to 250 mm  
**Ends :** Between flanges PN16/40  
**Min Temperature :** - 28°C  
**Max Temperature :** + 200°C  
**Max Pressure :** 40 Bars up to DN80, 16 bars over  
**Specifications :** With ISO 5211 mounting pad  
Contents ball  
Double antistatic device  
Atex

**Materials :** Carbon steel or Stainless steel

## WAFER BALL VALVE ADLER TYPES FA1/FA2/FB1/FB2

### SPECIFICATIONS :

Full bore  
Anti blow-out stem  
With ISO 5211 mounting pad  
Wafer type  
Between flanges R.F. PN40 up to DN80, PN16 over  
Double antistatic device  
Contents ball with removable body  
Threaded flanges holes  
Fugitive emissions according to ISO 15848-1 : 2003 Class A  
3 PTFE filled with graphite chevrons rings on stem  
Packing with elastic rings  
Forged carbon or stainless steel body  
Hollow body for DN125  
Polyamid epoxy painting blue color RAL5012, 35 µ thickness for carbon steel types

### USE :

Chemical and pharmaceutical industries, petrochemical industries, hydraulic installation, compressed air  
Min and max Temperature Ts : - 28°C to + 200°C  
Max Pressure Ps : 40 bars up to DN80 , 16 bars over  
Vacuum : 10<sup>-2</sup> torr  
Compressed air (ambient temperature) : 10 bars up to DN50, 8 bars from DN65 to 100  
Steam : 8 bars up to DN50, 6 bars from DN65 to 100

### RANGE :

Forged carbon steel body PN40 up to DN80 and PN16 over **Ref. 720** from DN 15 to DN 250 (\*)  
Forged stainless steel body PN40 up to DN80 excepted for DN65 PN16, PN16 over **Ref. 770** from DN 15 to DN 200 (\*)  
Possible with gear box IP67 **Ref. 9830260 to 264** from DN 15 to DN 250  
(\*) : PN40 on request

### ACCESSORIES AND OPTIONS :

Locking device **Ref. 9830140 to 9830148** from DN 15 to DN 200  
Stainless steel handle **Ref. 9830170 to 9830178** from DN 15 to DN 200  
Steel oval handle **Ref. 9830271 to 9830272** from DN 15 to DN 32  
Stainless steel oval handle  
Stainless steel bolting  
Carbon steel stem extension 100 mm **Ref. 9830273 to 9830280** from DN 15 to DN 200  
Stainless steel stem extension 100 mm **Ref. 9830193 to 9830200** from DN 15 to DN 200  
Deadman **Ref. 9830160 to 9830165** from DN 15 to DN 50  
Dry cleaned oxygen **Ref. 9830150 to 9830155** from DN 15 to DN 200  
Standard dry cleaned  
Seat PTFE filled with glass, graphite, stainless steel or metal  
Pocket less seat PTFE or PTFE filled with glass  
Heating jacket carbon or stainless steel  
Specials coated  
Hole in the ball for overpressure device  
Double o ring on stem

### ENDS :

Between flanges PN40 up to DN80 excepted for DN65 PN16 ( for Ref.770 ), PN16 over

**WAFER BALL VALVE ADLER TYPES FA1/FA2/FB1/FB2**

MATERIALS DN 15-40 ( ADLER FA1 TYPE ) :

PACKING GASKETS :

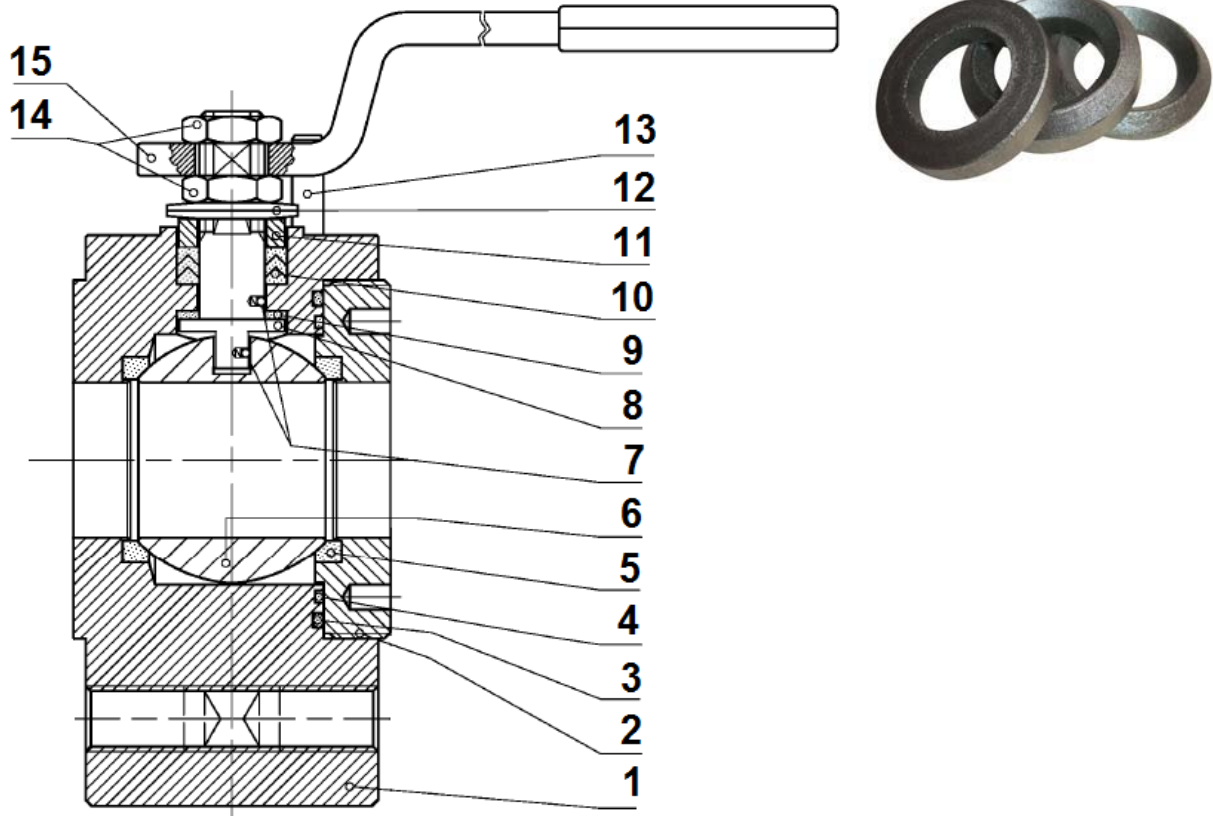

(\* : Included in gaskets kit)

Item	Designation	Materials Ref. 720 DN15-40	Materials Ref. 770 DN15-40
1	Body	ASTM A105	ASTM A479 316L
2	Ends	ASTM A105	ASTM A479 316L
3*	O ring	FKM	
4*	Body gasket	PTFE	
5*	Seat	PTFE	
6	Ball	ASTM A351 CF3	ASTM A351 CF3M
7	Double antistatic device	ASTM A479 S31600	
8	Stem	ASTM A182 F 316 L	
9*	Stem gasket	PTFE	
10*	Chevron packing	PTFE filled with graphite	
11	Gland follower	ASTM A479 S31600	
12	Elastic ring	C72 / 50 Cr V4 galvanized	
13	Pin	UNI 3740 8.8 galvanized	
14	Nut	UNI 3740-6S galvanized	
15	Handle	UNI 5946 Fe 37 galvanized	

**WAFER BALL VALVE ADLER TYPES FA1/FA2/FB1/FB2**

**MATERIALS 720 DN 50-250 AND 770 DN 50-100 ( ADLER FA2 TYPE ) :**

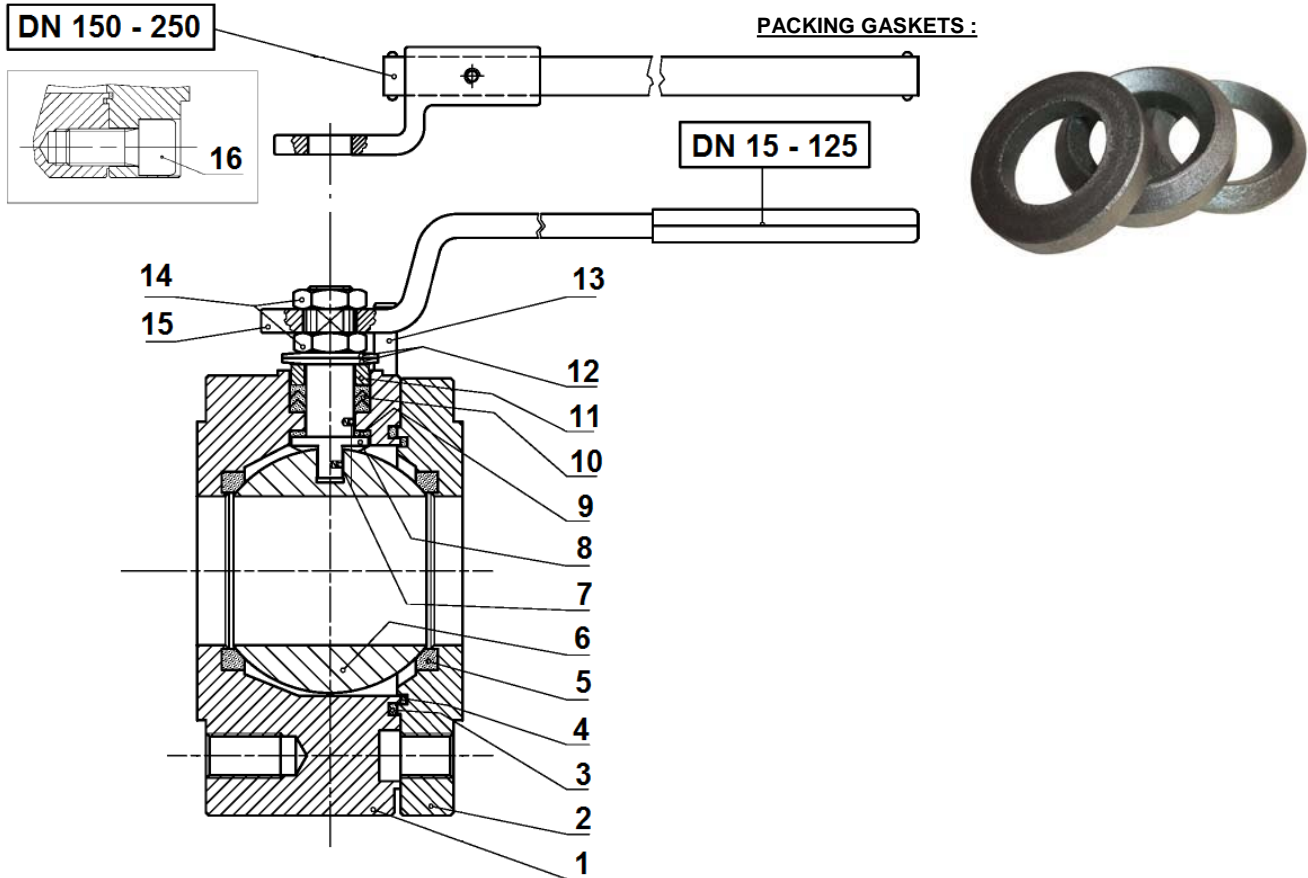

(\* : Included in gaskets kit)

Item	Designation	Materials Ref. 720 DN50-250	Materials Ref. 770 DN50-100
1	Body	ASTM A105	ASTM A479 316L
2	Ends	ASTM A105	ASTM A479 316L
3*	O ring	FKM	
4*	Body gasket	PTFE	
5*	Seat	PTFE	
6	Ball	ASTM A351 CF3	ASTM A351 CF3M
7	Double antistatic device	ASTM A479 S31600	
8	Stem	ASTM A479 304L	ASTM A182 F 316 L
9*	Stem gasket	PTFE	
10*	Chevron packing	PTFE filled with graphite	
11	Gland follower	ASTM A479 S31600	
12	Elastic ring	C72 / 50 Cr V4 galvanized	
13	Pin	UNI 3740 8.8 galvanized	
14	Nut	UNI 3740-6S galvanized	
15	Handle	UNI 5946 Fe 37 galvanized	
16	Screw	UNI 3740 8.8 galvanized	

**WAFER BALL VALVE ADLER TYPES FA1/FA2/FB1/FB2**

MATERIALS 770 DN 125 ( ADLER FB1 TYPE ) :

PACKING GASKETS :

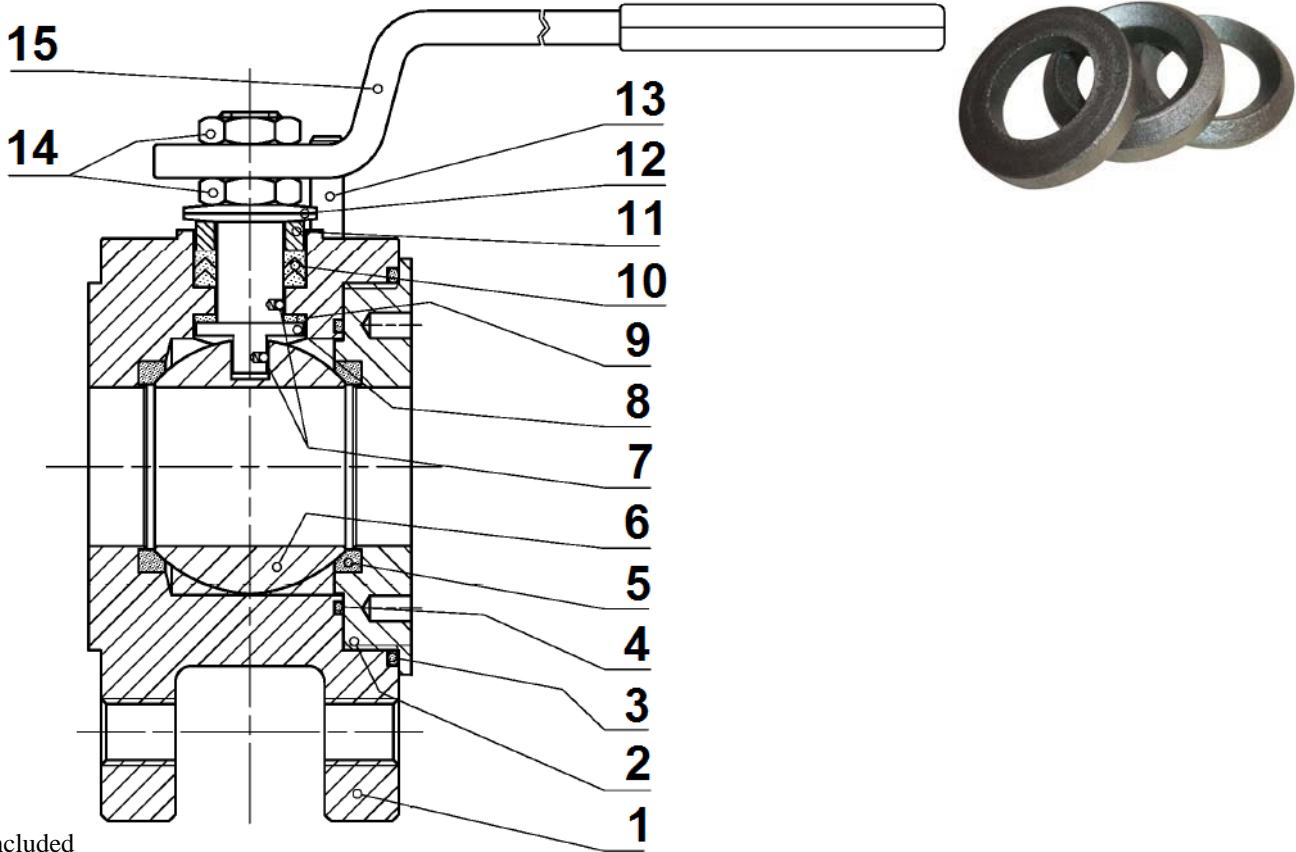

(\* : Included in gaskets kit)

Item	Designation	Materials Ref. 770 DN125
1	Body	ASTM A351 CF8M
2	Ends	ASTM A479 316L
3*	O ring	FKM
4*	Body gasket	PTFE
5*	Seat	PTFE
6	Ball	ASTM A351 CF8
7	Double antistatic device	ASTM A479 S31600
8	Stem	ASTM A182 F 316 L
9*	Stem gasket	PTFE
10*	Chevron packing	PTFE filled with graphite
11	Gland follower	ASTM A479 S31600
12	Elastic ring	C72 / 50 Cr V4 galvanized
13	Pin	UNI 3740 8.8 galvanized
14	Nut	UNI 3740-6S galvanized
15	Handle	UNI 5946 Fe 37 galvanized

**WAFER BALL VALVE ADLER TYPES FA1/FA2/FB1/FB2**

**MATERIALS 770 DN 150-200 ( ADLER FB2 TYPE ) :**

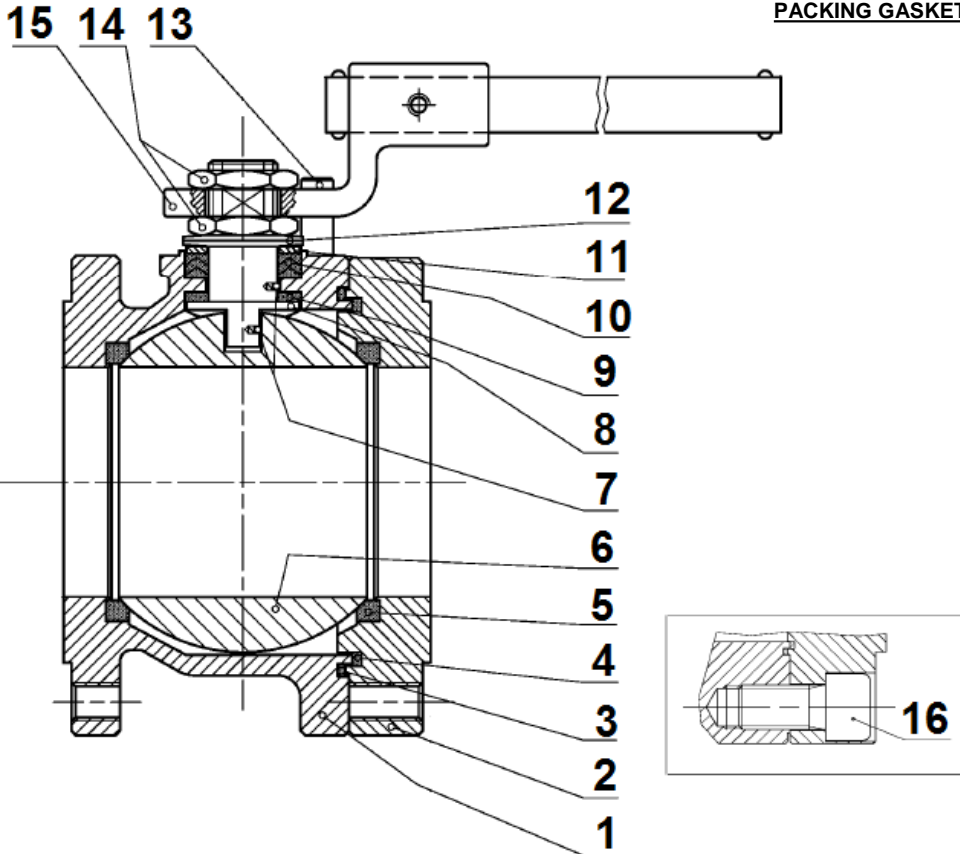

**PACKING GASKETS :**



(\* : Included in gaskets kit)

Item	Designation	Materials Ref. 770 DN150-200
1	Body	ASTM A351 CF8M
2	Ends	ASTM A479 316L
3*	O ring	FKM
4*	Body gasket	PTFE
5*	Seat	PTFE
6	Ball	ASTM A351 CF8
7	Double antistatic device	ASTM A479 S31600
8	Stem	ASTM A182 F 316 L
9*	Stem gasket	PTFE
10*	Chevron packing	PTFE filled with graphite
11	Gland follower	ASTM A479 S31600
12	Elastic ring	C72 / 50 Cr V4 galvanized
13	Pin	UNI 3740 8.8 galvanized
14	Nut	UNI 3740-6S galvanized
15	Handle	UNI 5946 Fe 37 galvanized
16	Screw	UNI 3740 8.8 galvanized

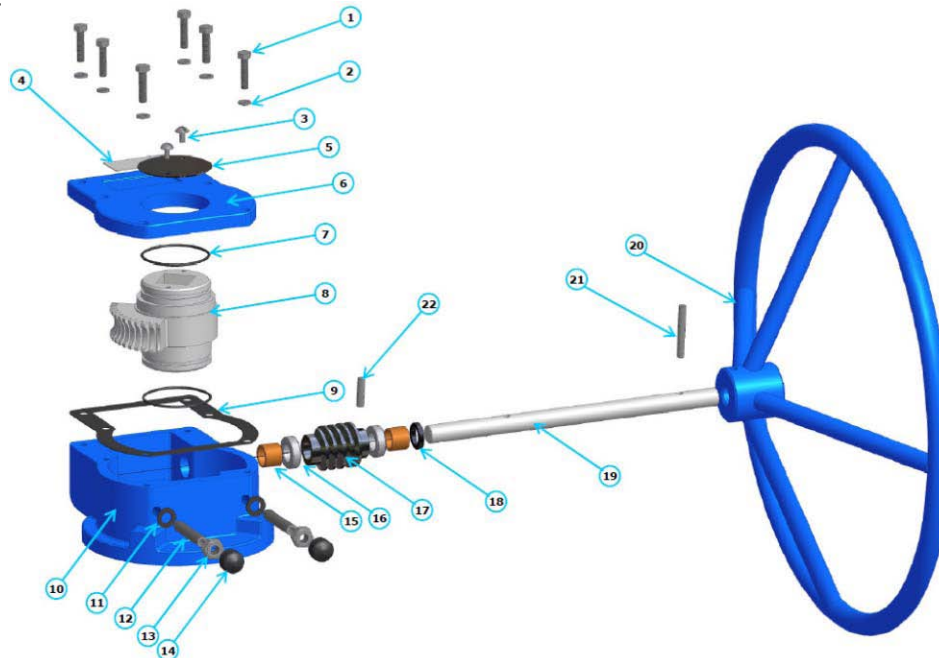
**WAFER BALL VALVE ADLER TYPES FA1/FA2/FB1/FB2**
**GEARBOX MATERIALS :**

Item	Designation	Materials Ref. 9830260 to 9830264
1	Box screw	DIN 933 class 8.8
2	Washer	C72
3	Indicator screw	DIN 86 class A2
4	ID plate	Steel S235 JR
5	Indicator	Steel S235 JR
6	Cover	Ductile iron EN GJS-400-15
7	O ring	NBR 70 Shore A
8	Wheel	Ductile iron EN GJS-500-7
9	Cover gasket	SL509AT
10	Box	Ductile iron EN GJS-400-15
11	Gasket	NBR 70 Shore A
12	Adjusting bolt	DIN 915 class 12.9
13	Nut	DIN 934 class 8G
14	Bolt cap	NBR 70 Shore A
15	Bushing	G Cu Sn10
16	Axial ball bearing	-
17	Worm	C45 + NiP
18	Gasket	NBR 70 Shore A
19	Input shaft	C45 + NiP
20	Handwheel	Steel S235 JR
21	Dowell pin	DIN 7 Class A2
22	Dowell pin	DIN 7 Class A2

**WAFER BALL VALVE ADLER TYPES FA1/FA2/FB1/FB2**

SIZE DN 15 – 40 FA1 TYPE ( in mm ) :

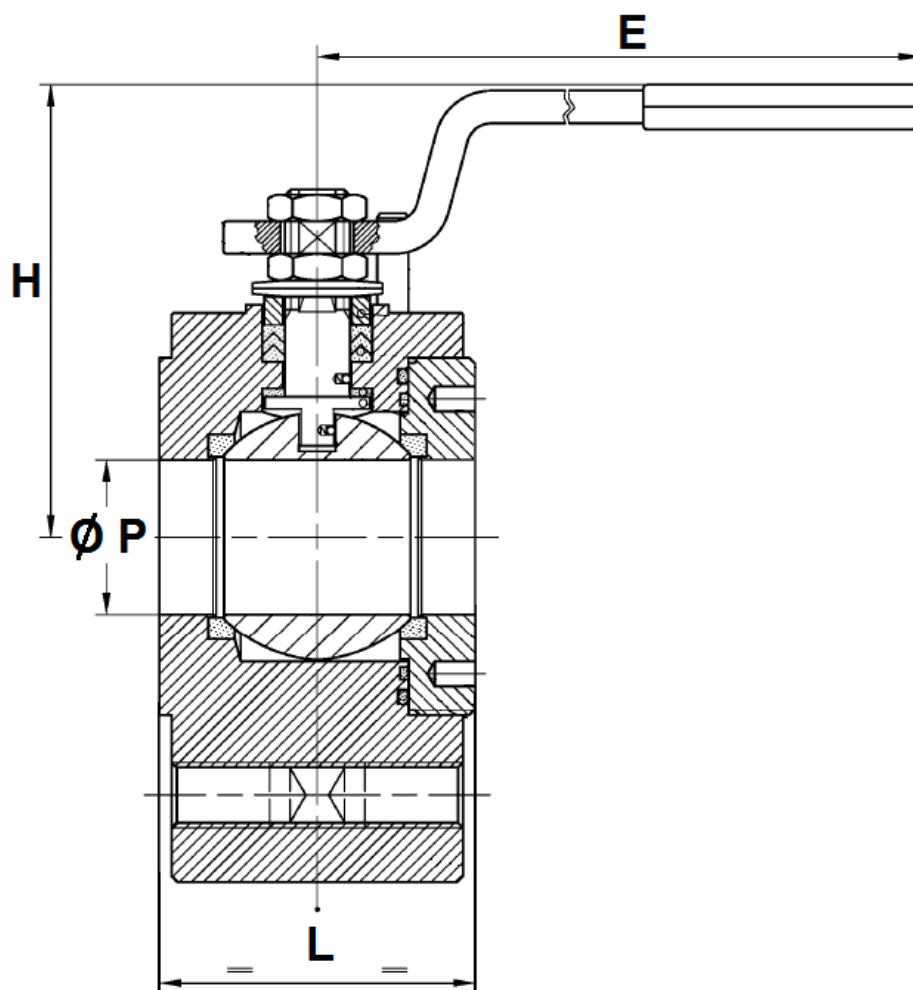

Ref.	DN	15	20	25	32	40
720 / 770 FA1	Ø P	15	19	25	30	38
	L	35	35	43	51	64
	E	145	145	185	185	280
	H	66	68	85	91	110
	Weight ( Kg )	1.6	1.9	2.8	4.8	7.2



**WAFER BALL VALVE ADLER TYPES FA1/FA2/FB1/FB2**

SIZE 720 DN 50 - 250 AND 770 DN 50 - 100 FA2 TYPE ( in mm ) :

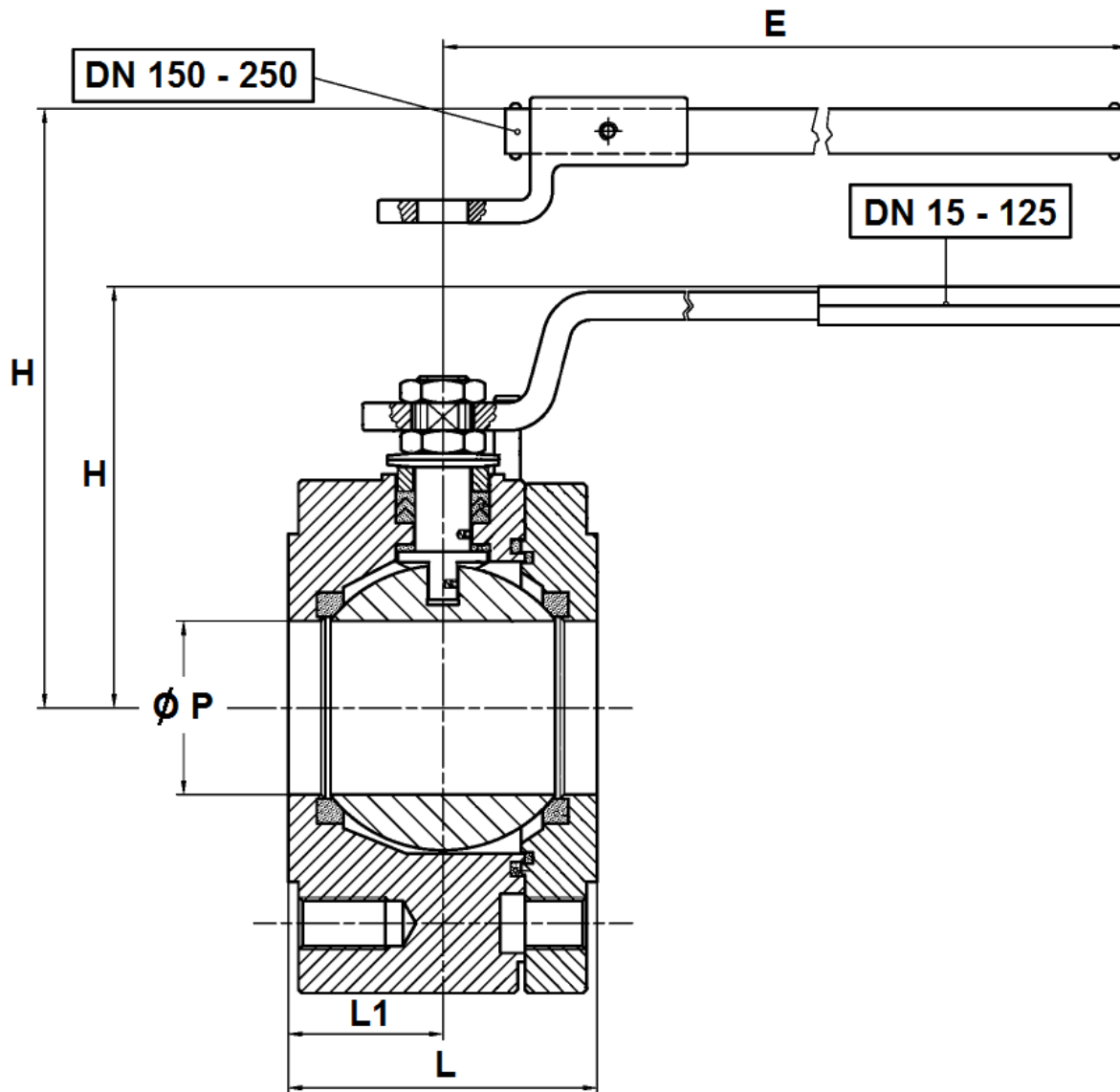

Ref.	DN	50	65	80	100	125	150	200	250
720 / 770 FA2	Ø P	51	64	76	101	118	152	203	254
	L	85	103	120	155	182	234	310	314
	L1	42.5	51.5	60	77.5	91	117	155	157
	E	280	370	370	470	650	750	900	1000
	H	120	144	152	174	188	256	294	343
	Weight (Kg)	11.5	18	23.5	35	51	90	121	180

**WAFER BALL VALVE ADLER TYPES FA1/FA2/FB1/FB2**

SIZE 770 DN 125 FB1 TYPE ( in mm ) :

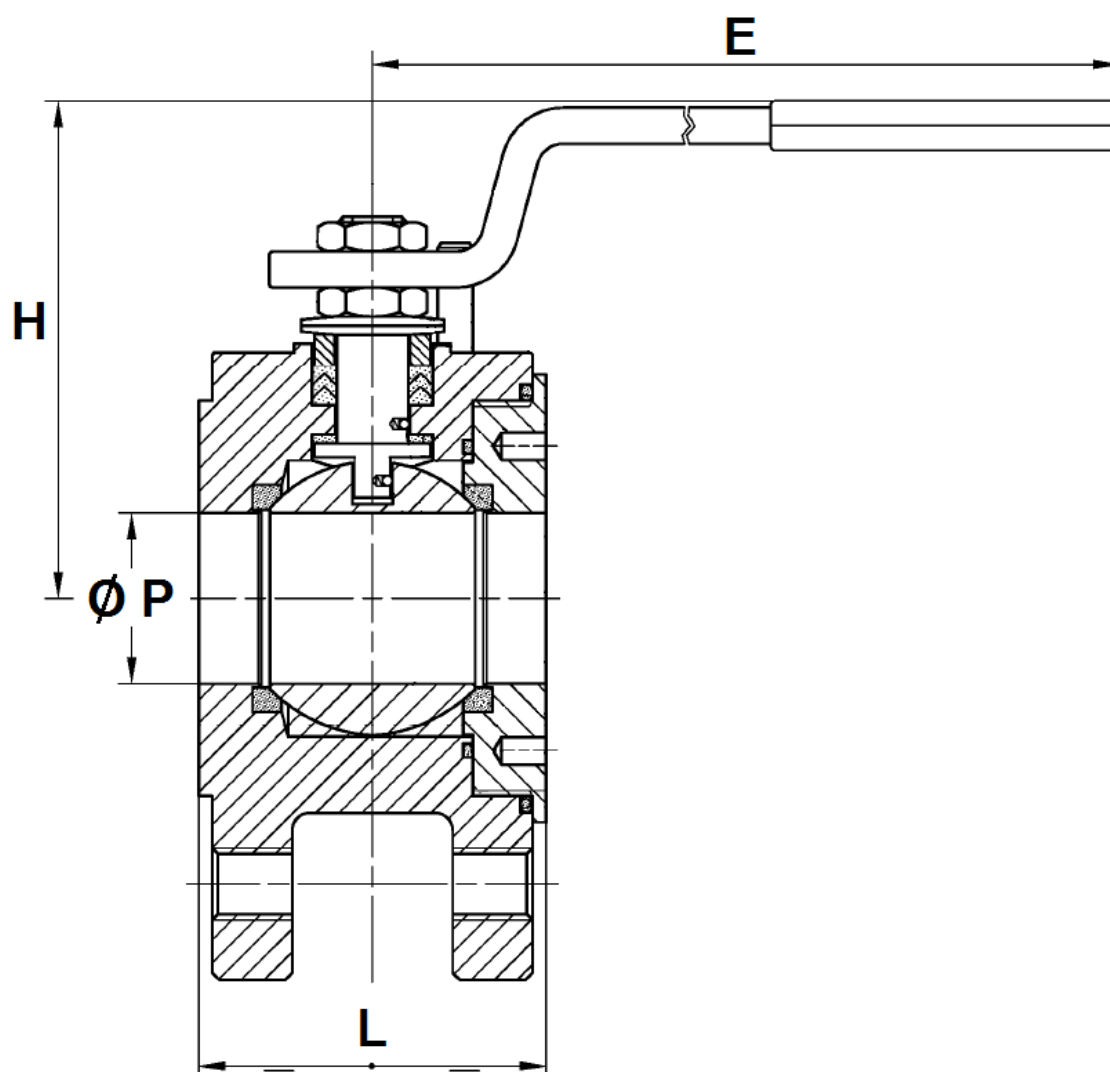

Ref.	DN	125
770 FB1	Ø P	118
	L	182
	E	650
	H	188
	Weight (Kg)	31

**WAFER BALL VALVE ADLER TYPES FA1/FA2/FB1/FB2**

SIZE 770 DN 150 - 200 FB2 TYPE ( in mm ) :

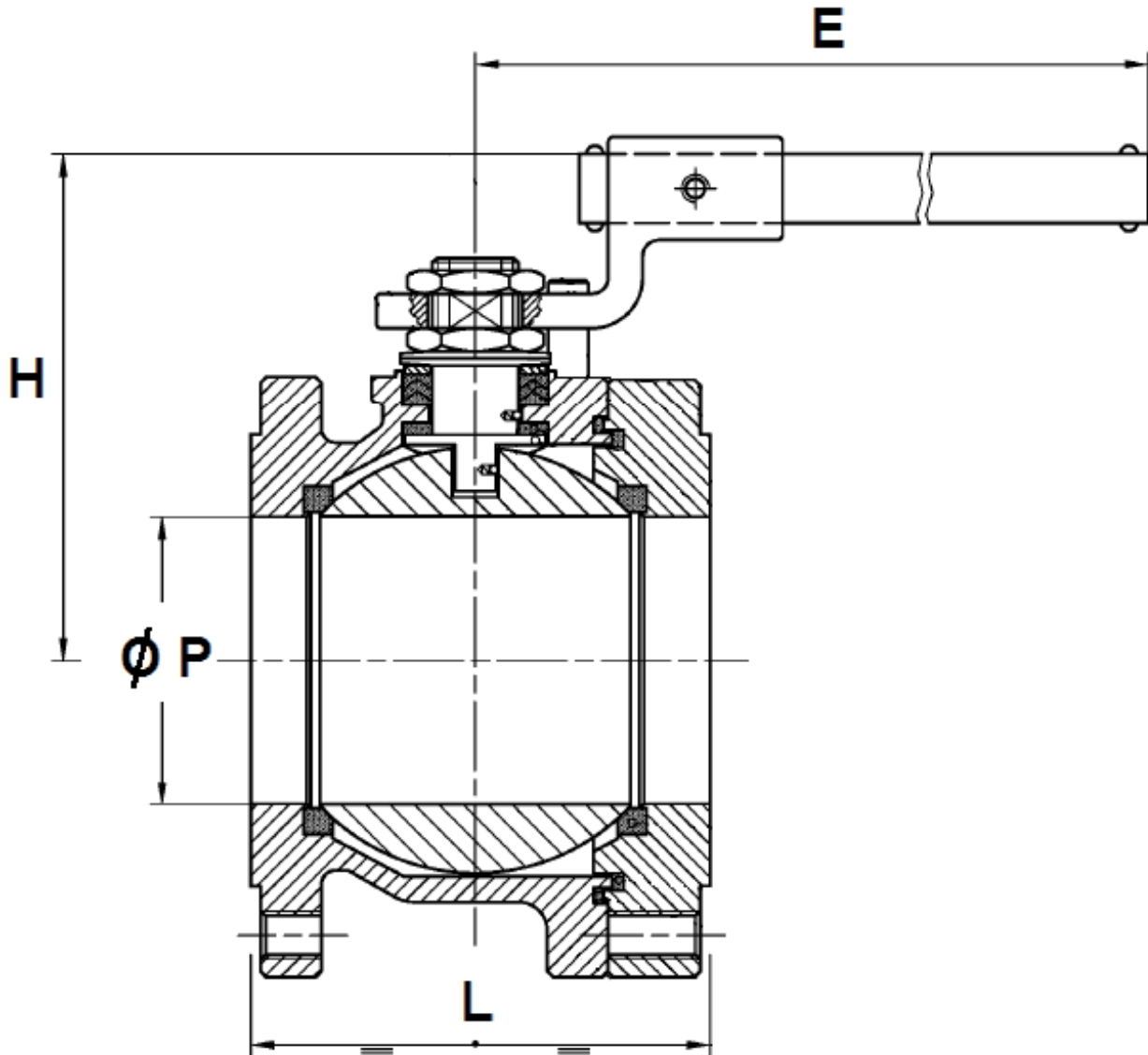

Ref.	DN	150	200
770 FB2	Ø P	152	203
	L	234	310
	E	750	900
	H	256	294
	Weight (Kg)	90	121

**WAFER BALL VALVE ADLER TYPES FA1/FA2/FB1/FB2**

STEM AND ISO MOUNTING PAD SIZE DN 15 – 40 FA1 TYPE ( in mm ) :

**DN 15 – 40 ( FA1 TYPE )**

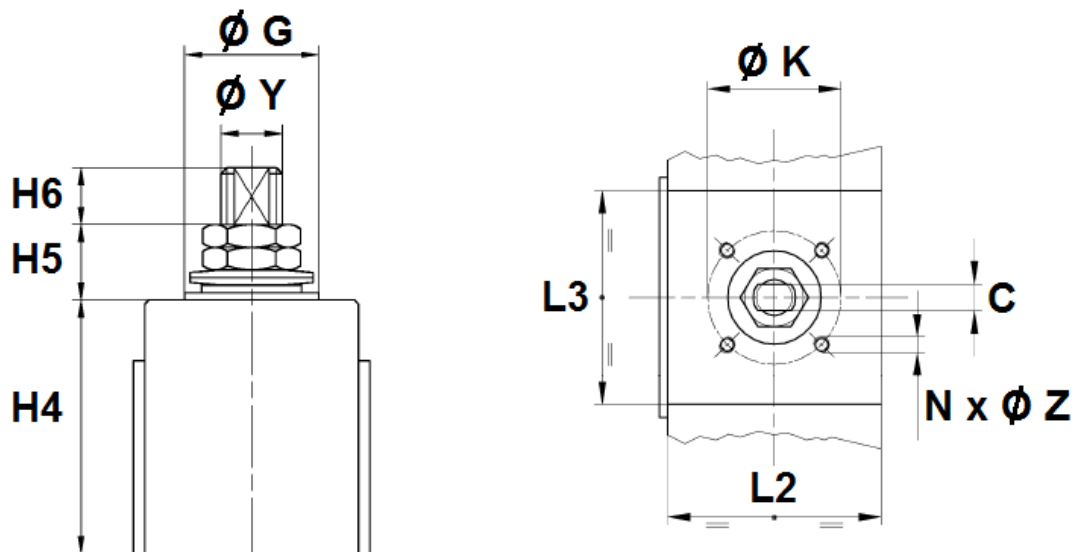

DN	15	20	25	32	40
H4	32.5	35	41	46.5	55
H5	7.5	7.5	16.5	16.5	19.5
H6	7	7	10	10	10
C	6	6	8	8	10
Ø Y	10	10	12	12	16
Ø K	36	36	36	36	50
ISO	F03	F03	F03	F03	F05
N x Ø Z	4 x M5	4 x M5	4 x M5	4 x M5	4 x M6
Ø G	25	25	25	25	35
L2	33	33	40	48	58
L3	69	78	81	105	102

**WAFER BALL VALVE ADLER TYPES FA1/FA2/FB1/FB2**

STEM AND ISO MOUNTING PAD SIZE REF.720 DN50-250 AND 770 DN50-100 FA2 TYPE ( in mm ) :

**REF. 720 DN 50 – 250 AND REF. 770 DN 50 - 100 ( FA2 TYPE )**

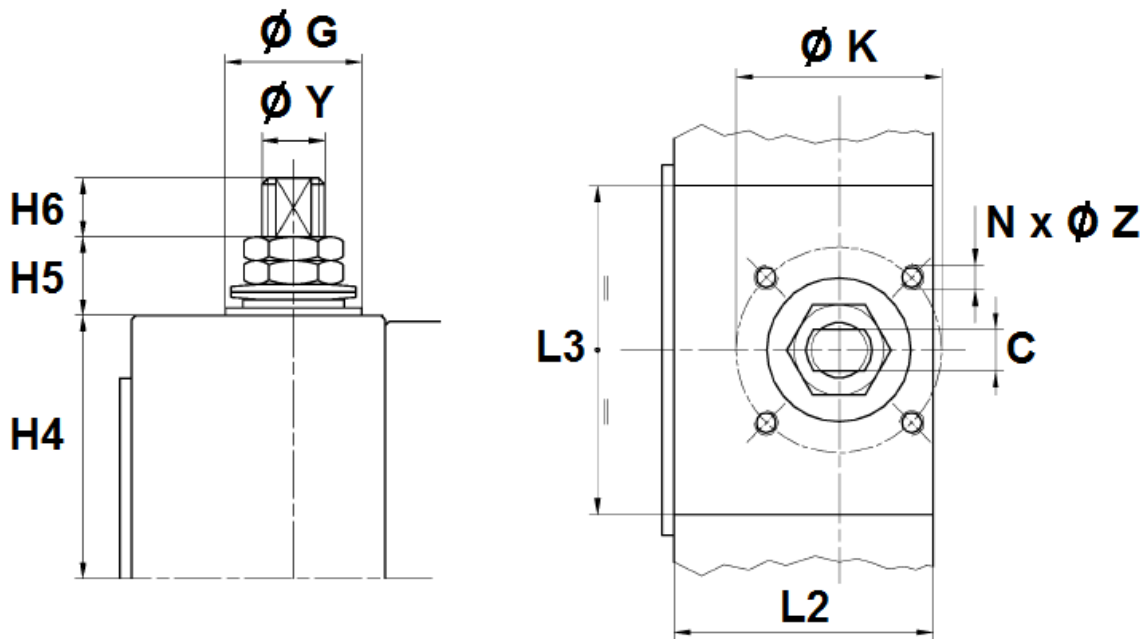

DN	50	65	80	100	125	150	200	250
H4	65	82	90.5	99.5	114	144	182	225.5
H5	21	24	24	27	26	34	37	40
H6	10	12	12	17	18	19	20	20
C	10	14	14	18	18	28	32	36
Ø Y	16	22	22	30	30	42	48	56
Ø K	50	70	70	70	102	125	140	165
ISO	F05	F07	F07	F07	F10	F12	F14	F16
N x Ø Z	4 x M6	4 x M8	4 x M8	4 x M8	4 x M10	4 x M12	4 x M16	4 x M20
Ø G	35	55	55	55	70	85	100	130
L2	62	79	88	105	133	150	228	257
L3	102	85	80	86	112	110	95	150

**WAFER BALL VALVE ADLER TYPES FA1/FA2/FB1/FB2**

STEM AND ISO MOUNTING PAD SIZE REF.770 DN125-200 FB1 AND FB2 TYPES ( in mm ) :

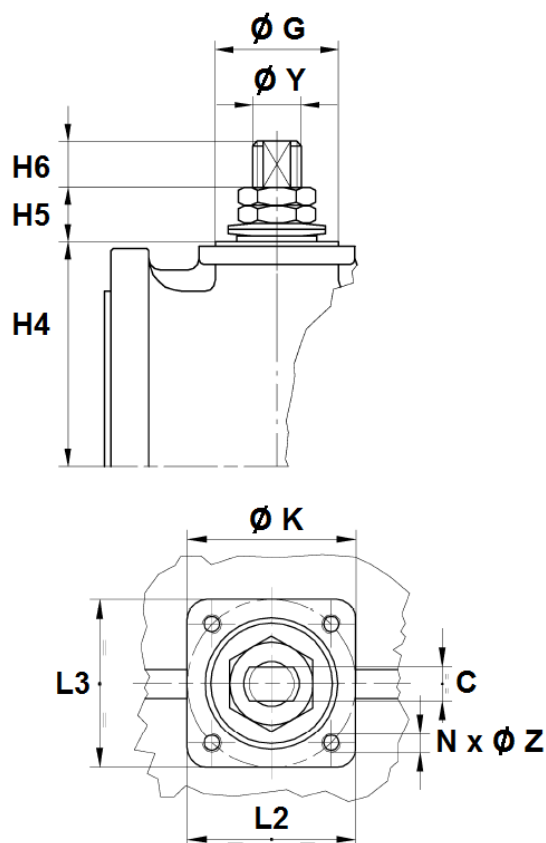
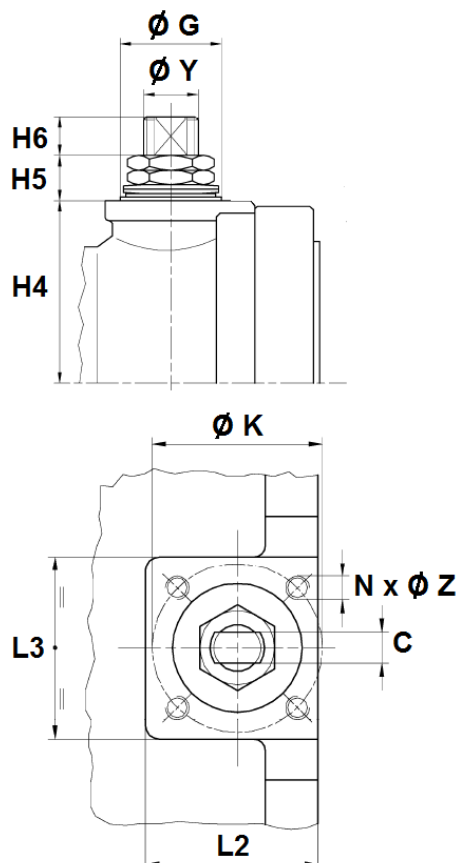
**REF. 770 DN125 ( FB1 TYPE )**

**REF. 770 DN 150-200 ( FB2 TYPE )**

DN	125	150	200
H4	113	144	183
H5	27	34	36
H6	17	19	20
C	18	28	32
Ø Y	30	42	48
Ø K	102	125	140
ISO	F10	F12	F14
N x Ø Z	4 xM10	4 xM12	4 xM16
Ø G	70	85	100
L2	97	116	135
L3	97	113	135

**WAFER BALL VALVE ADLER TYPES FA1/FA2/FB1/FB2**

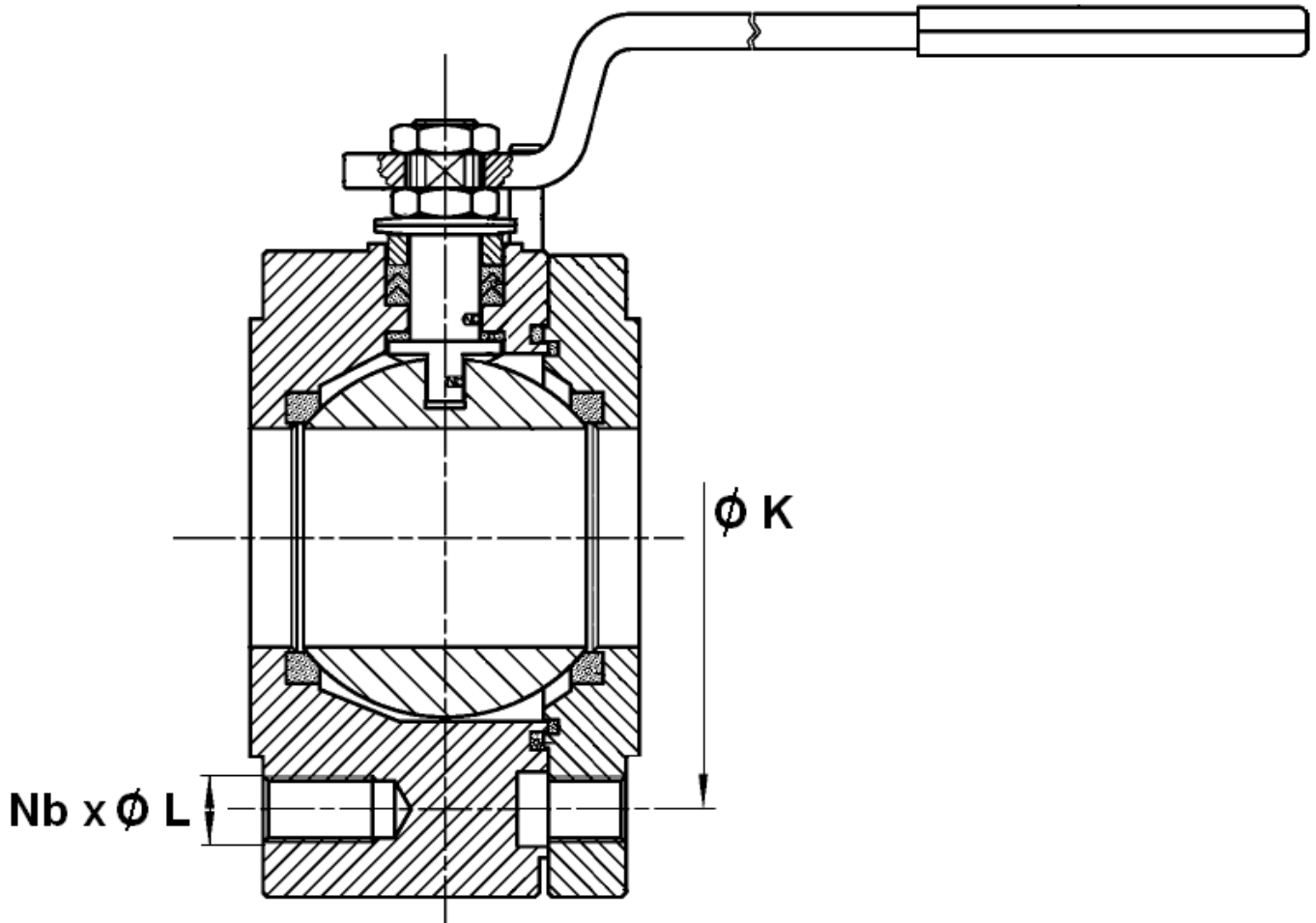
FLANGES THREADED HOLES SIZE ( in mm ) :



DN	15 (PN40)	20 (PN40)	25 (PN40)	32 (PN40)	40 (PN40)	50 (PN40)	65 (PN16)	65 (PN40)	80 (PN40)	100 (PN16)	125 (PN16)	150 (PN16)	200 (PN16)	250 (PN16)
Ø K	65	75	85	100	110	125	145	160	160	180	210	240	295	355
Nb x Ø L	4 x M12	4 x M12	4 x M12	4 x M16	4 x M16	4 x M16	4 x M16	8 x M16	8 x M16	8 x M16	8 x M16	8 x M20	12xM20	12xM24
Suggested screw length	30	35	35	40	40	40	40	45	45	40	45	45	50	65

**WAFER BALL VALVE ADLER TYPES FA1/FA2/FB1/FB2**

DEADMAN SIZE ( in mm ) :

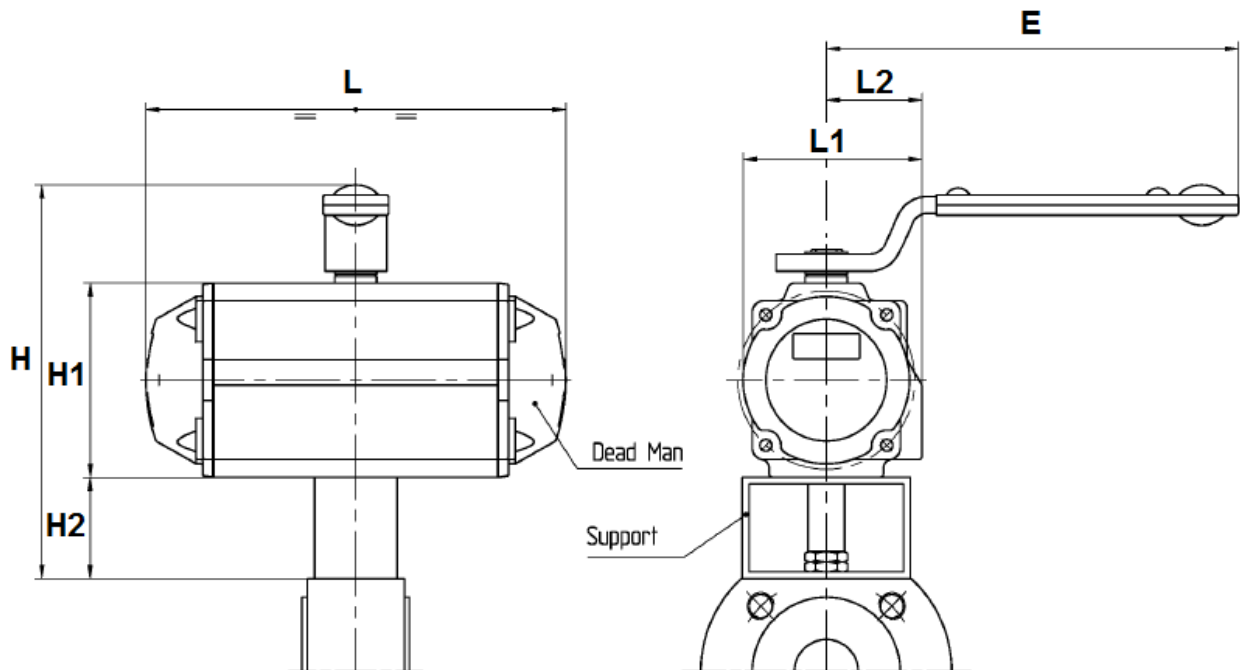

DN	15	20	25	32	40	50
Ref.	9830160	9830161	9830162	9830163	9830164	9830165
L	142	142	161	161	214	252
L1	70.5	70.5	83.5	83.5	94	105
L2	41.5	41.5	47.5	47.5	51	55.5
E	185	185	185	185	280	370
H	157	157	169	169	215	233
H1	69	69	85	85	102	115
H2	40	40	40	40	60	60



**WAFER BALL VALVE ADLER TYPES FA1/FA2/FB1/FB2**

GEARBOX SIZE ( in mm ) :

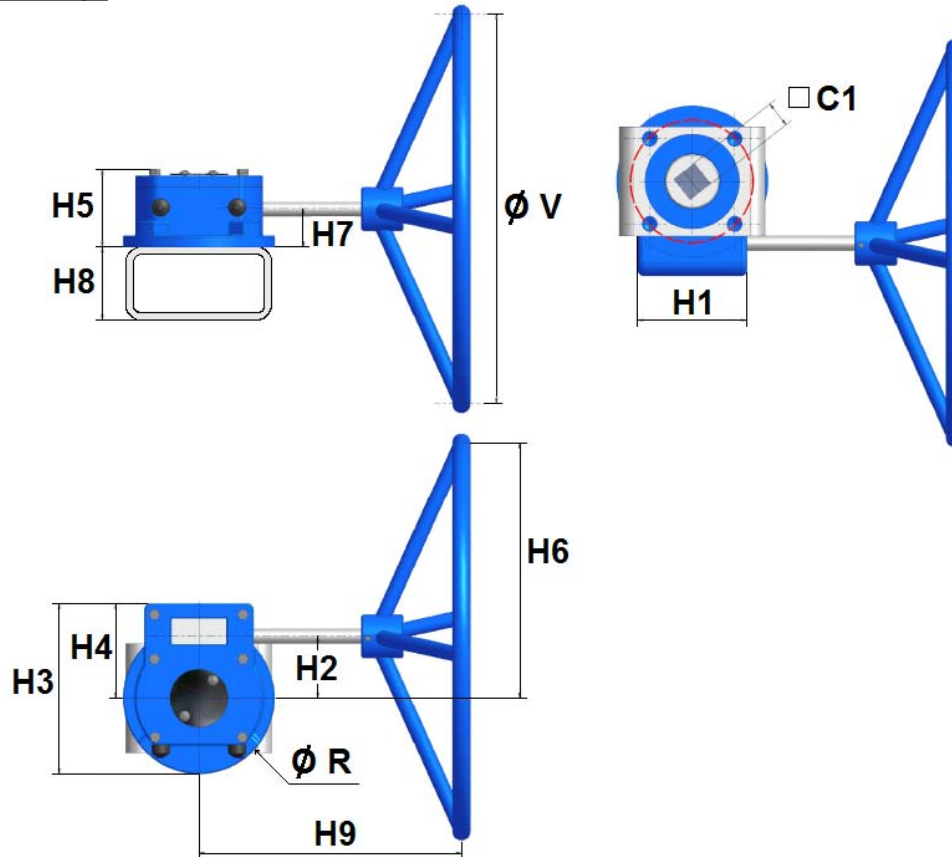

DN	15-50	65-80	100-150	200	250
C1	22	22	22	27	36
H1	57	57	100	120	150
H2	46	46	55	74	96
H3	98	98	143	188	237
H4	50.5	50.5	79.5	99	129.5
H5	56	56	73	97	106
H6	106	146	205	274	396
H7	34	34	35	48	55
H8	60	60	80	80	100
H9	117	131	250	274	365
Ø R	98	98	143	188	237
Ø V	120	200	300	400	600
Weight ( Kg )	2.2	2.3	4.5	9.1	18.2
Ref.	9830260	9830261	9830262	9830263	9830264

**WAFER BALL VALVE ADLER TYPES FA1/FA2/FB1/FB2**
**GEARBOX SPECIFICATIONS :**

DN	15-50	65-80	100-150	200	250
Ref.	9830260	9830261	9830262	9830263	9830264
Ratio factor	40 :1	40 :1	37 :1	34 :1	38 :1
Input torque ( Nm )	35	34	43	83	152
Output torque ( Nm )	100	150	500	1000	2000

**BOLT TIGHTENING TABLE ( FOR FLANGES ) ( in Nm ) :**

DN	15	20	25	32	40	50	65	80	100	125	150	200	250
THREADED	M12	M12	M12	M16	M16	M16	M16	M16	M16	M16	M20	M20	M24
Torque ( Nm ) for carbon steel bolting	84.8	84.8	84.8	205	205	205	205	205	205	205	400	400	691
Torque ( Nm ) for stainless steel bolting	53	53	53	128	128	128	128	128	128	128	250	250	432

**TORQUE VALUES ( in Nm without safety coefficient ) :**

DN	15	20	25	32	40	50	65	80	100	125	150	200	250
Torque ( Nm ) PN16	5.4	10.8	13.5	16	31	40	66	78	140	158	340	510	800
Torque ( Nm ) PN40	6.5	12.5	14.5	18	33	44	72	88	156	230	520	610	1060

We recommend a safety coefficient of 2 to choose the actuator

## WAFER BALL VALVE ADLER TYPES FA1/FA2/FB1/FB2

STANDARDS :

Fabrication according to ISO 9001:2008

DIRECTIVE 97/23/CE : CE N° 0038  
Risk category III module H

Designing according to BS EN 12516-2

Construction according to ISO 14313

Materials according to NACE MR 01-75

Pressure tests according to EN 12266-1, range A

Marking according to EN 19

Fire safe according to BS 6755-2 ( **on request** )

Fugitive emissions according to ISO 15848-1 : 2003 Range A

SIL3 according to IEC/EN 61508 ( on request )

ISO 5211 mounting pad

Length according to EN 558-6 series 100

ATEX Group II Category 2 G/2Dc Zone 1 & 21 Zone 2 & 22 ( optional marking )

**ADVICE :** Our opinion and our advice are not guaranteed and SFERACO shall not be liable for the consequences of damages.  
The customer must check the right choice of the products with the real service conditions.

**WAFER BALL VALVE ADLER TYPES FA1/FA2/FB1/FB2****INSTALLATION INSTRUCTIONS****GENERAL GUIDELINES :**

Ensure that the valves to be used are appropriate for the conditions of the installation (type of fluid, pressure and temperature).

Be sure to have enough valves to be able to isolate the sections of piping as well as the appropriate equipment for maintenance and repair.

Ensure that the valves to be installed are of correct strength to be able to support the capacity of their usage.

**Installation of all circuits should ensure that their function can be automatically tested on a regular basis (at least two times a year).**

**INSTALLATION INSTRUCTIONS :**

**Before installing the valves, clean and remove any objects from the pipes** (in particular bits of sealing and metal) which could obstruct and block the valves.

**Ensure that both connecting pipes either side of the valve (upstream and downstream) are aligned (if they're not, the valves may not work correctly).**

**Make sure that the two sections of the pipe (upstream and downstream) match, the valve unit will not absorb any gaps. Any distortions in the pipes may affect the tightness of the connection, the working of the valve and can even cause a rupture.** To be sure, place the kit in position to ensure the assembling will work.

**If sections of piping do not have their final support in place, they should be temporarily fixed. This is to avoid unnecessary strain on the valve.**

Tighten the bolts in cross.

It's recommended to operate the valve ( open and close ) 1 to 2 times per year