

3 PIECES BALL VALVE PN63



- Size :** DN 8 to 100 mm
- Ends :** Threaded BSP or NPT , Socket or Butt Welding
- Min Temperature :** -20°C
- Max Temperature :** + 180°C
- Max Pressure :** 63 Bars up to DN20
- Specifications :** Anti blow-out stem
Locking device
Full bore

Materials : Carbon or stainless steel

3 PIECES BALL VALVE PN63

SPECIFICATIONS :

Full bore
Anto blow-out stem
PTFE packing
Locking device
Stem extension in SS 304 (option)
Blue handle cover possible
Black oxide finish for carbon steel valves Ref.796/797/798 and 7961

USE :

Chemical and pharmaceutical industries, petrochemical industries
Min and max Temperature Ts : -20°C to + 180°C
Max Pressure Ps : 63 bars up to DN20, 40 bars from DN25 to 50, 25 bars from DN65 to 80 and 20 bars for DN100 (see graph under)

PRESSURE / TEMPERATURE GRAPH (STEAM AND COMPRESSED AIR EXCLUDED) :

Pressure (Bar)

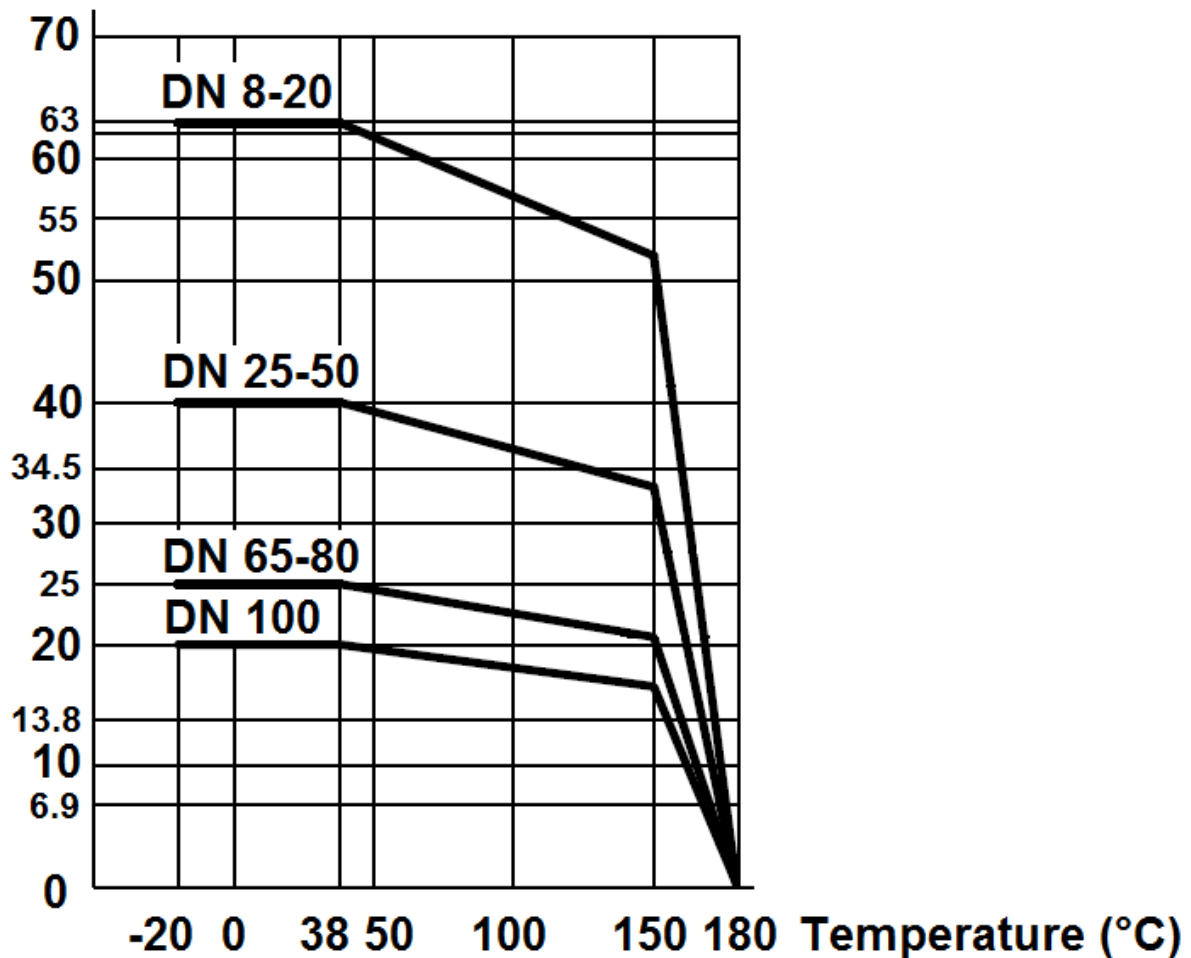

3 PIECES BALL VALVE PN63

RANGE :

Carbon steel Ref. **796/797/798** from DN 8 to DN 100 and Ref. **7961** from DN 8 to DN 50
 Stainless steel Ref. **744/790/791/792** from DN 8 to DN 100
 Blue handle cover Ref. **9830444-9830449** from DN 8 to DN 100

ENDS :

Female / female threaded BSP Ref. **790/796**
 Female / female threaded NPT Ref. **744/7961**
 Socket Welding Ref. **792/798**
 Butt welding Ref. **791/797**

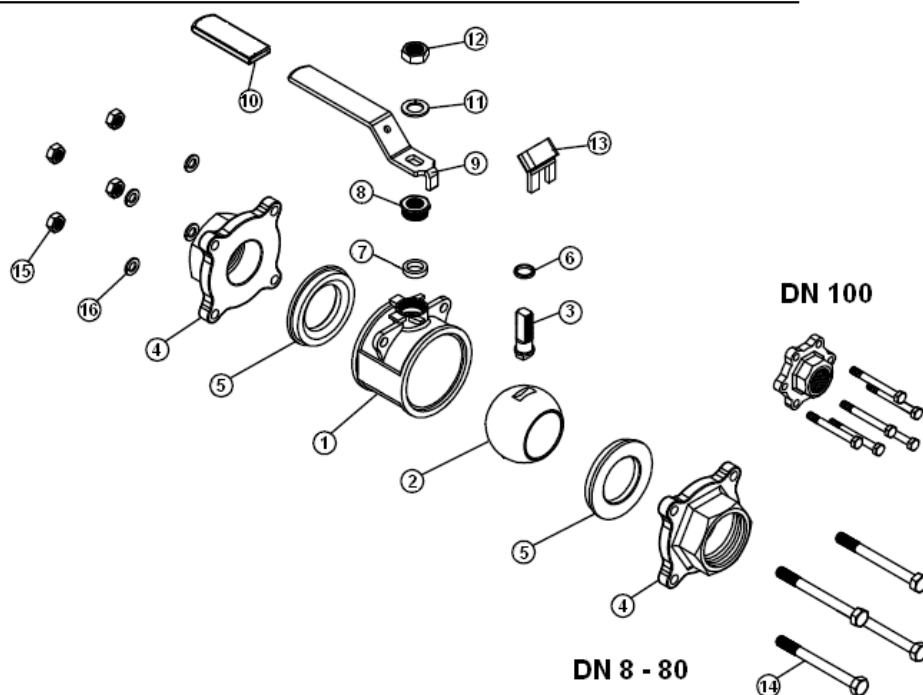
MATERIALS FOR STAINLESS STEEL TYPES DN8 AND FROM DN15 TO 100 REF. 790/791/792/744 :

Item	Designation	Materials Ref. 790/791/792/744 DN8 and DN15-100
1	Body	ASTM A351 CF8M
2	Ball	ASTM A351 CF8M
3	Stem	SS 316
4	Ends	ASTM A351 CF8M
5*	Seat	PTFE filled with 15% glass fiber
6*	Thrust washer	PTFE
7*	Packing	PTFE
8	Packing nut	SS 304
9	Handle	SS 304
10	Handle cover	Plastic
11	Handle washer	SS 304
12	Handle nut	SS 304
13	Locking device	SS 304
14	Bolt	SS 201
15	Nut	SS 304
16	Washer	SS 304

(* : Included in gaskets kit)

3 PIECES BALL VALVE PN63

MATERIALS FOR STAINLESS STEEL TYPES DN10 REF. 790/791/792/744 :

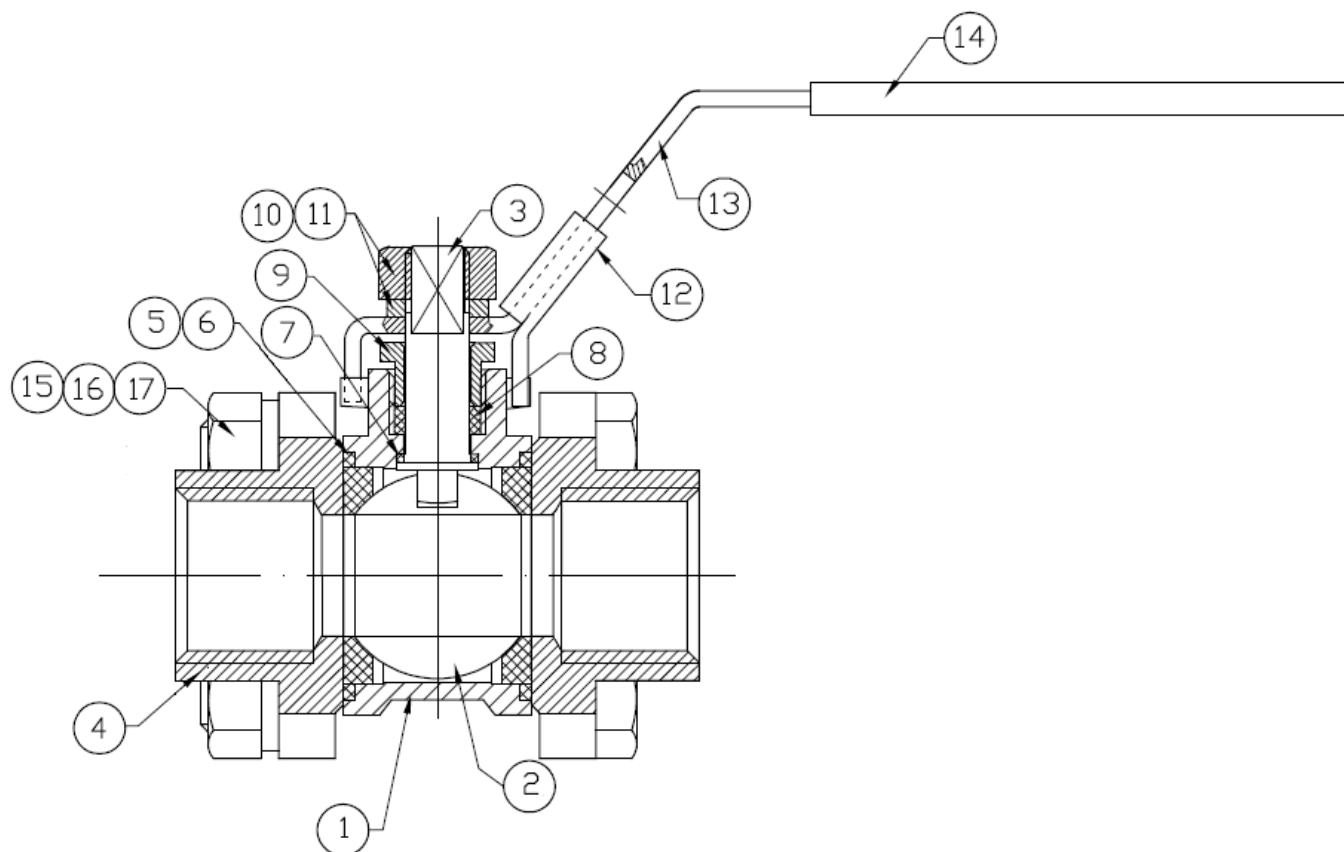

Item	Designation	Materials Ref. 790/791/792/744 DN10
1	Body	ASTM A351 CF8M
2	Ball	ASTM A351 CF8M
3	Stem	SS 316
4	Ends	ASTM A351 CF8M
5*	Seat	PTFE filled with 15% glass fiber
6*	Body gasket	PTFE filled with 15% glass fiber
7*	Thrust washer	PTFE
8*	Packing	PTFE
9	Packing nut	SS 304
10	Handle nut	SS 304
11	Handle washer	SS 304
12	Locking device	SS 304
13	Handle	SS 304
14	Handle cover	Plastic
15	Bolt	SS 201
16	Nut	SS 304
17	Washer	SS 304

(* : Included in gaskets kit)

3 PIECES BALL VALVE PN63

MATERIALS FOR CARBON STEEL TYPES DN8 – 40 REF. 796/7961/797/798 :

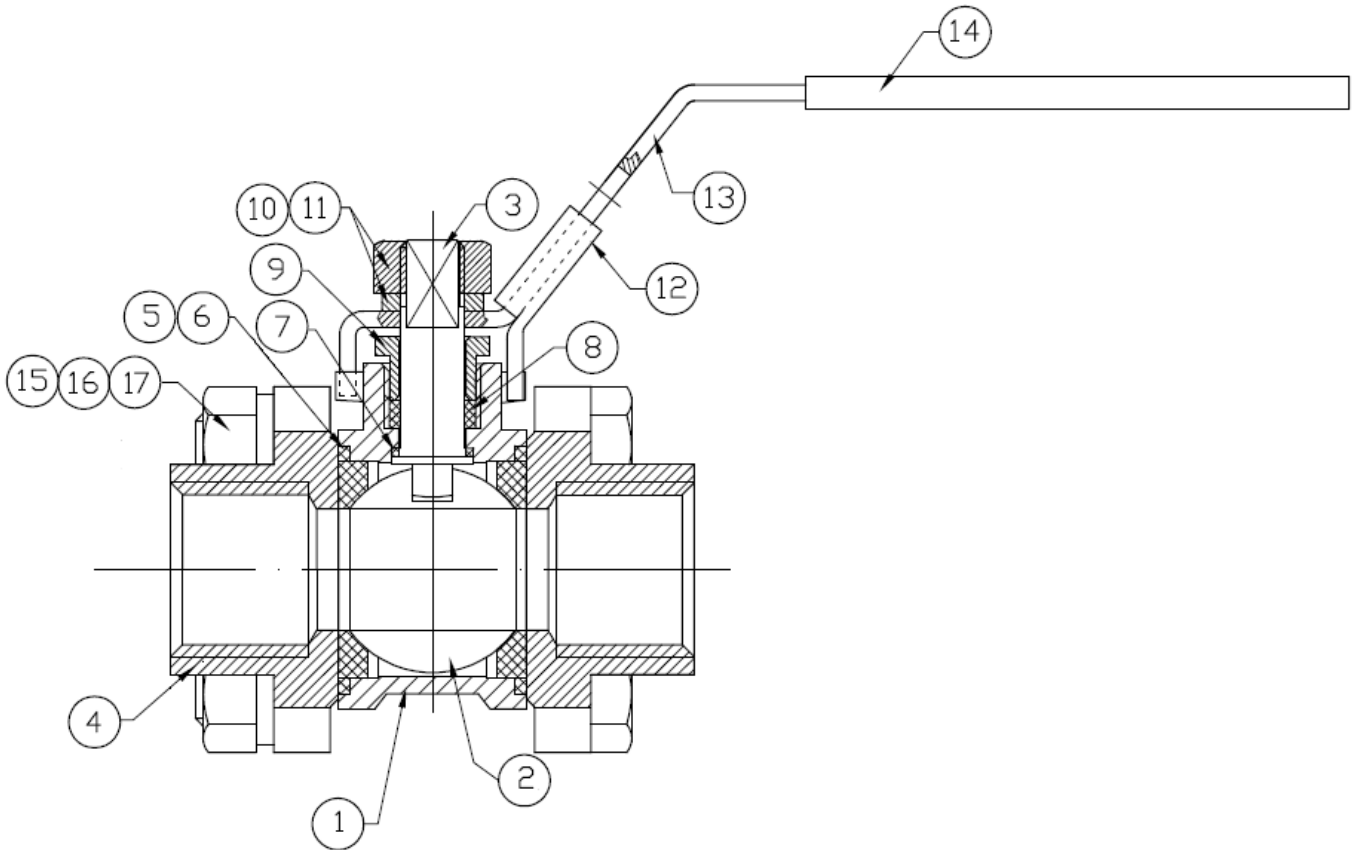

Item	Designation	Materials Ref. 796/7961/797/798 DN8-40
1	Body	ASTM A216 WCB
2	Ball	SS 304
3	Stem	SS 304
4	Ends	ASTM A216 WCB
5*	Seat	PTFE filled with 15% glass fiber
6*	Body gasket	PTFE filled with 15% glass fiber
7*	Thrust washer	PTFE
8*	Packing	PTFE
9	Packing nut	SS 304
10	Handle nut	SS 304
11	Handle washer	SS 304
12	Locking device	SS 304
13	Handle	SS 304
14	Handle cover	Plastic
15	Bolt	SS 201
16	Nut	SS 304
17	Washer	SS 304

(* : Included in gaskets kit)

3 PIECES BALL VALVE PN63

MATERIALS FOR CARBON STEEL TYPES DN50 TO 100 REF. 796/7961/797/798 :

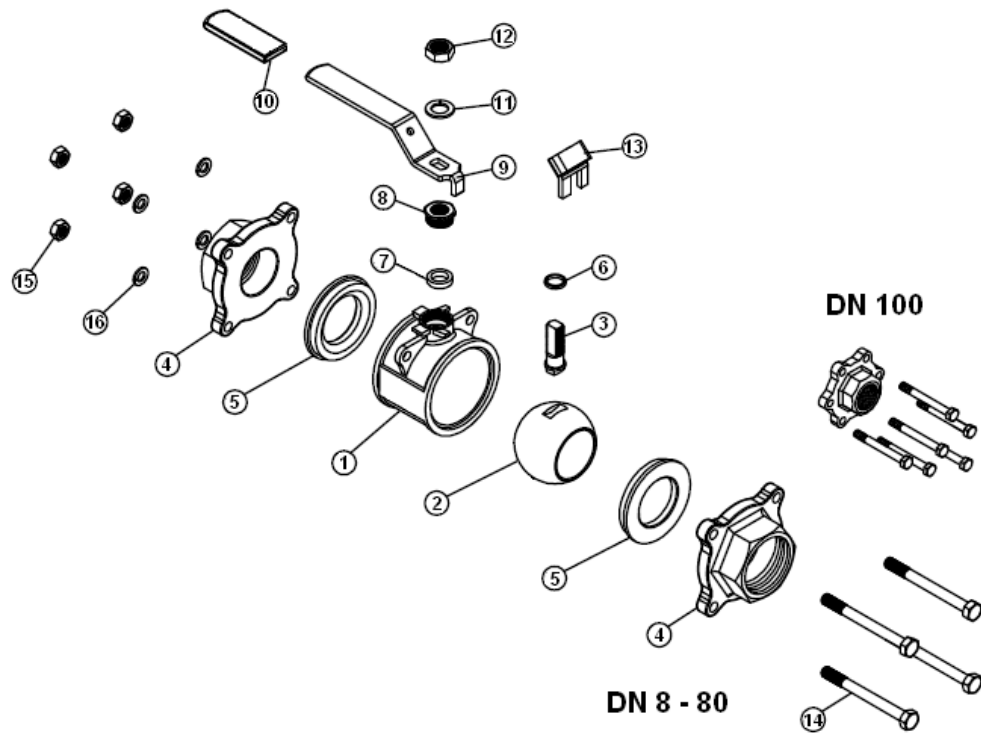

Item	Designation	Materials 796/7961/797/798 DN50-100
1	Body	ASTM A216 WCB
2	Ball	SS 304
3	Stem	SS 304
4	Ends	ASTM A216 WCB
5*	Seat	PTFE filled with 15% glass fiber
6*	Thrust washer	PTFE
7*	Packing	PTFE
8	Packing nut	SS 304
9	Handle	SS 304
10	Handle cover	Plastic
11	Handle washer	SS 304
12	Handle nut	SS 304
13	Locking device	SS 304
14	Bolt	SS 201
15	Nut	SS 304
16	Washer	SS 304

(* : Included in gaskets kit)

3 PIECES BALL VALVE PN63

SIZE THREADED STAINLESS STEEL TYPES (in mm) REF. 790 / 744 :

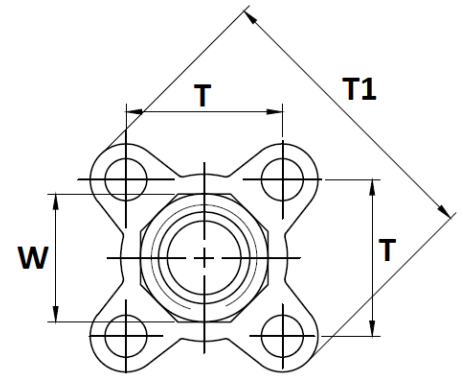
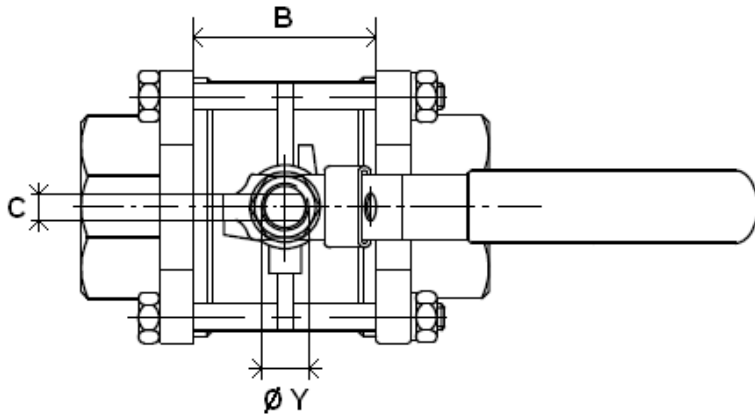

DN 1/4" - 3"

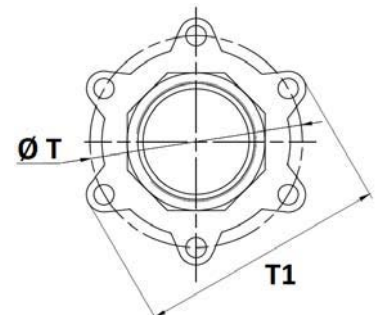
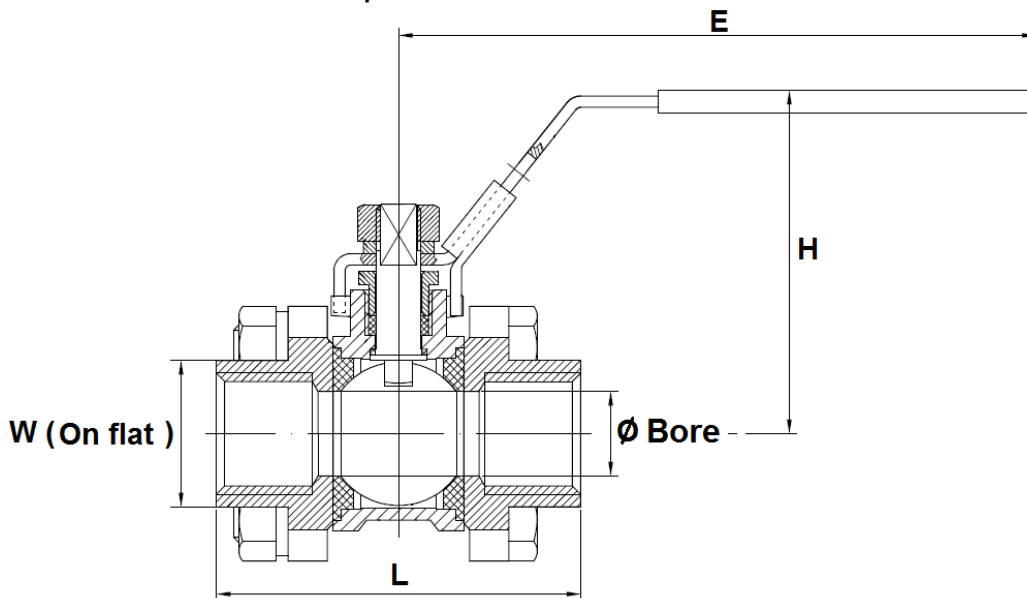

DN 4"

(2 parts seat for DN3/8")

Stem size :

Ref.	DN	1/4"	3/8"	1/2"	3/4"	1"	1"1/4"	1"1/2"	2"	2"1/2"	3"	4"
790	Ø Bore	9.2	12.8	15	20	25	32	38	50	65	80	100
	L	60	60	63	70	82	96	107	124	164.6	182.7	217.7
	B	22	22	23.3	28	34	43	49	62.4	88.1	100.2	119.1
	E	136	136	136	136	165	165	190	190	300	300	335
744	H	52	52	63	68	79	88	97	108	128	140	172
	Ø Y	8	8	8	8	10	10	12	12	14	14	20
Threaded	C	5	5	5	5	6.5	6.5	8.5	8.5	9.8	9.8	16
	T	27.2	27.2	31.8	40	45	53	63.3	78.8	98.3	116.6	200.5
	T1	51	51	59.5	71	80	91.5	106	132.8	164	194	231.5
	W	18	22	26	33	40	48	55	67	84.5	101	127
	Weight (Kg)	0.33	0.34	0.49	0.64	0.96	1.37	2.2	3.75	6.85	10.2	20.5

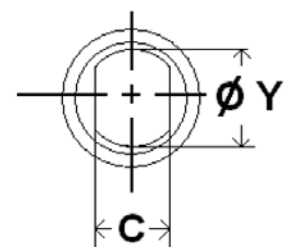

3 PIECES BALL VALVE PN63

SIZE THREADED CARBON STEEL TYPES (in mm) REF. 796 / 7961 :

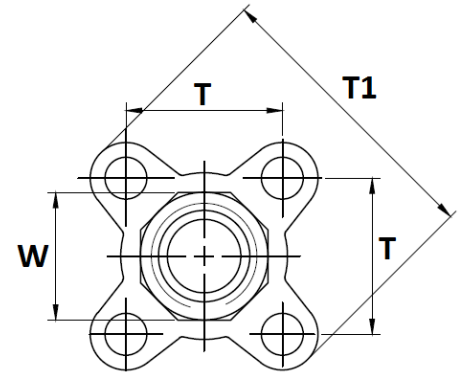
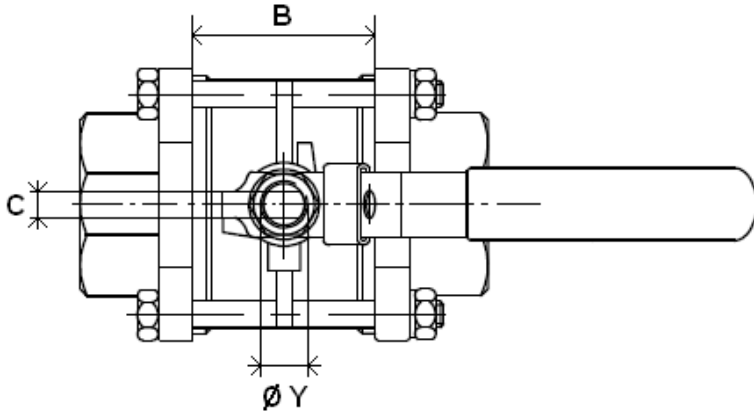

DN 1/4" - 3"

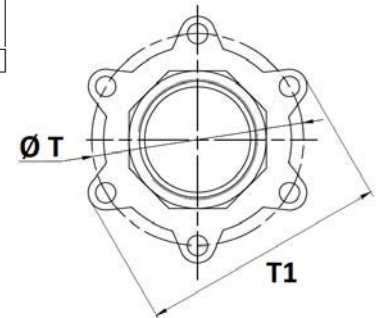
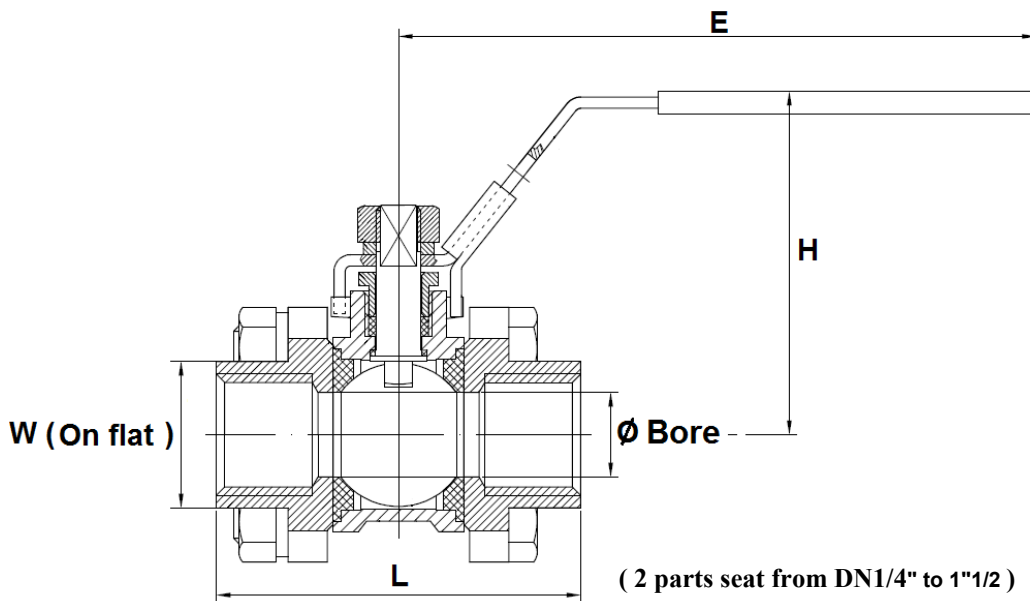

DN 4"

(2 parts seat from DN1/4" to 1"1/2)

Stem size :

Ref.	DN	1/4"	3/8"	1/2"	3/4"	1"	1"1/4"	1"1/2"	2"	2"1/2"	3"	4"	
796 7961 Threaded	Ø Bore	9.2	12.8	15	20	25	32	38	50	65	80	100	
	L	59	60	65.5	76.5	86.2	103.1	118	131.5	164.5	182.7	229.6	
	B	20	22	23.3	30.8	37.8	47	57	68	86.1	98.2	126.1	
	E	108	108	113	113	135	135	190	190	230	230	335	
	H	52	52	63	68	79	88	97	108	128	140	172	
	Ø Y	8	8	8	8	10	10	12	12	14	14	20	
	C	5	5	5	5	6.5	6.5	8.5	8.5	10	10	16	
	T	25	28	32	40	45	53	64	79	98	116	198	
	T1	48	51	59.5	71	80	91.5	108	132.8	164	194	234	
	W	20	22	26	33	40	48	55	67	87	101	130	
	Weight (Kg)		0.33	0.34	0.52	0.78	1.08	1.64	2.78	4.27	8.2	13	26

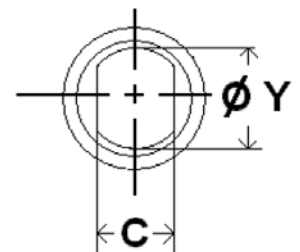

3 PIECES BALL VALVE PN63

SIZE BUTT WELDING STAINLESS STEEL TYPES (in mm) REF. 791 :

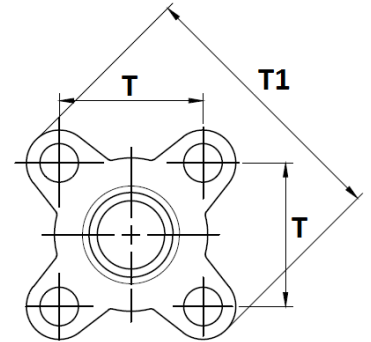
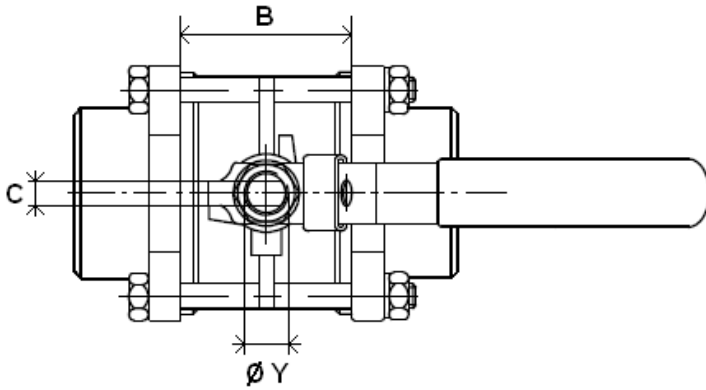

DN 1/4" - 3"

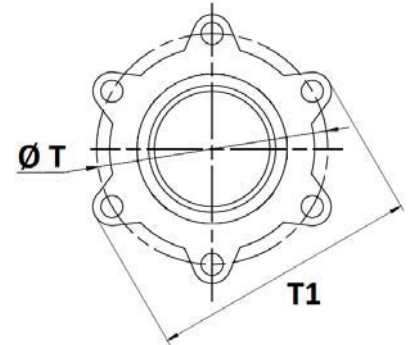
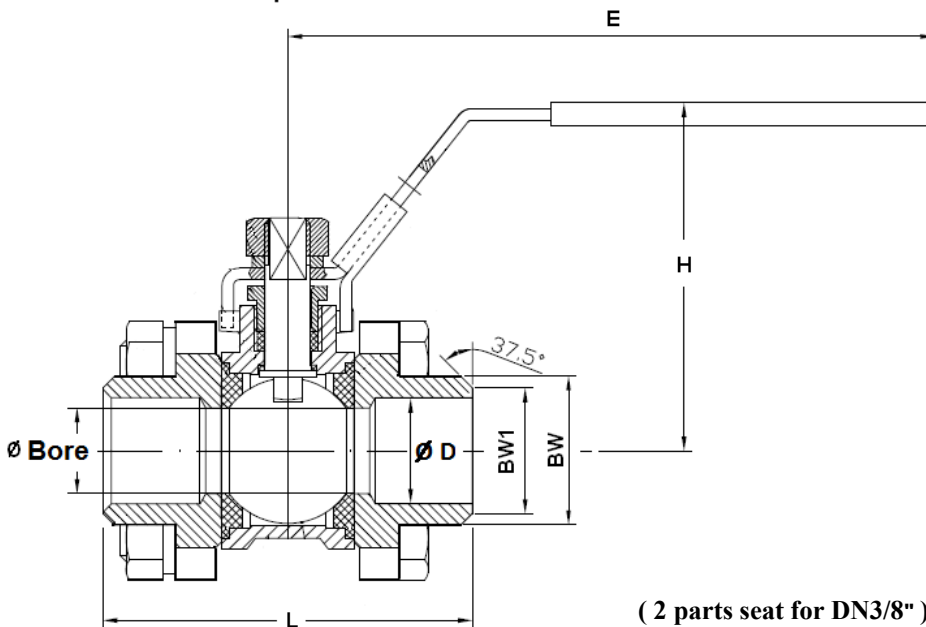

DN 4"

Stem size :

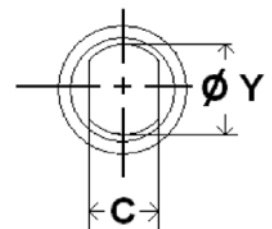

Ref.	DN	8	10	15	20	25	32	40	50	65	80	100	
791	Ø Bore	9.2	12.8	15	20	25	32	38	50	65	80	100	
	L	60	60	63	70	82	96	107	124	162.6	180.7	221.7	
	B	22	22	23.3	28	34	43	49	62.4	88.1	100.2	119.1	
	E	136	136	136	136	165	165	190	190	300	300	335	
	H	52	52	63	68	79	88	97	108	128	140	172	
	Ø Y	8	8	8	8	10	10	12	12	14	14	20	
	C	5	5	5	5	6.5	6.5	8.5	8.5	9.8	9.8	16	
	B.W.	T	27.2	27.2	31.8	40	45	53	63.3	78.8	98.3	116.6	200.5
		T1	51	51	59.5	71	80	91.5	106	132.8	164	194	231.5
		BW	14	17.5	22	27.5	34	43	49	61	76.5	90	115
BW1		12	14.5	17	22.5	28.6	36	43	54	68	84	104	
Ø D		9.2	12.8	15	20	25	32	39.8	50	65	80	100	
Weight (Kg)		0.33	0.33	0.49	0.64	0.96	1.37	2.2	3.75	6.85	10.2	20.5	

3 PIECES BALL VALVE PN63

SIZE BUTT WELDING CARBON STEEL TYPES (in mm) REF. 797 :

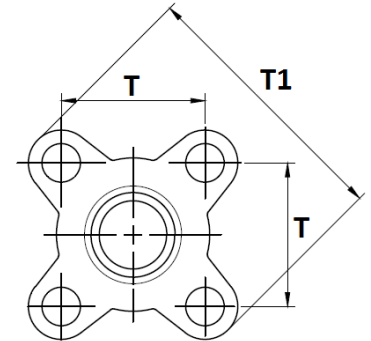
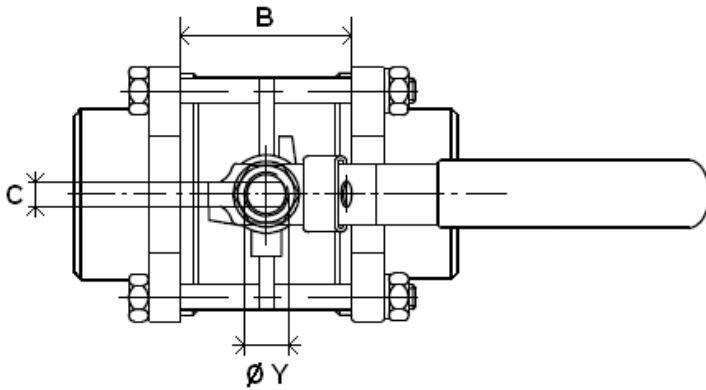

DN 1/4" - 3"

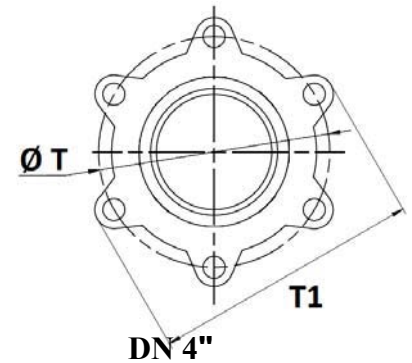
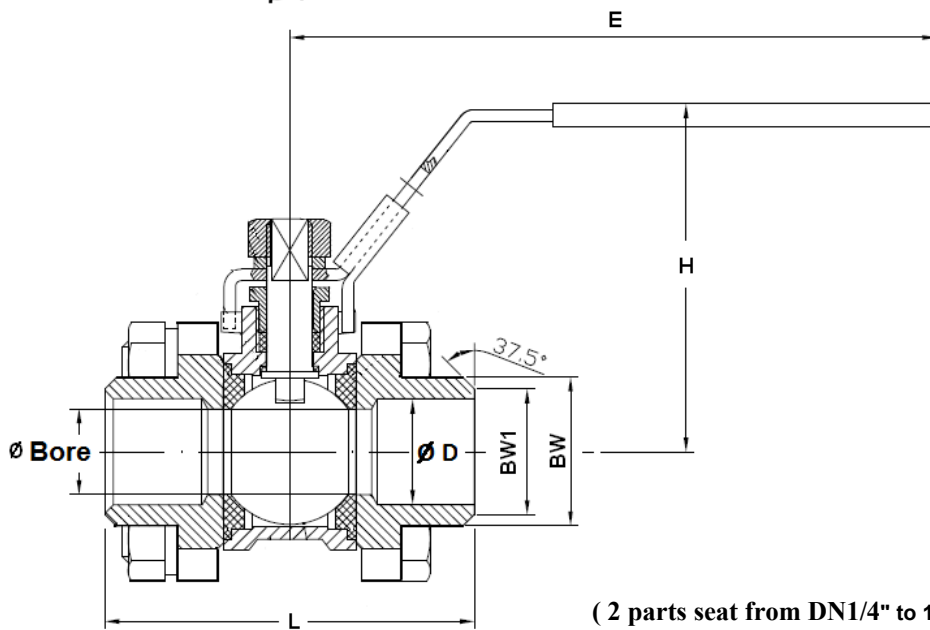

DN 4"

(2 parts seat from DN1/4" to 1"1/2)

Stem size :

Ref.	DN	8	10	15	20	25	32	40	50	65	80	100	
797	Ø Bore	9.2	12.8	15	20	25	32	38	50	65	80	100	
	L	59	60	65.5	76.5	86.2	103.1	118	131.5	174.5	192.7	239.6	
	B	20	22	23.3	30.8	37.8	47	57	68	96.1	108.2	136.1	
	E	108	108	113	113	135	135	190	190	230	230	335	
	H	52	52	63	68	79	88	97	108	128	140	172	
	Ø Y	8	8	8	8	10	10	12	12	14	14	20	
	C	5	5	5	5	6.5	6.5	8.5	8.5	10	10	16	
	B.W.	T	25	28	32	40	45	53	64	79	98	116	198
		T1	48	51	59.5	71	80	91.5	108	132.8	164	194	234
		BW	14	17.5	22	27.5	34	43	49	61	76.5	90	115
		BW1	12	14.5	17	22.5	28.6	36	43	54	68	84	104
		Ø D	9.2	12.8	15	20	25	32	39.8	50	65	80	100
Weight (Kg)		0.33	0.34	0.52	0.78	1.08	1.64	2.78	4.27	8.2	13	26	

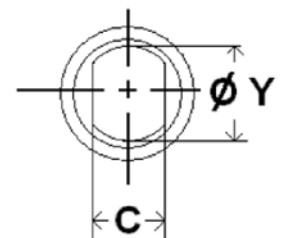

3 PIECES BALL VALVE PN63

SIZE SOCKET WELDING STAINLESS STEEL TYPES (in mm) REF. 792 :

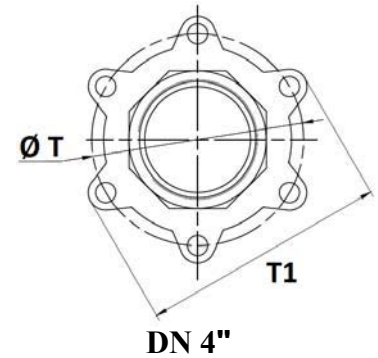
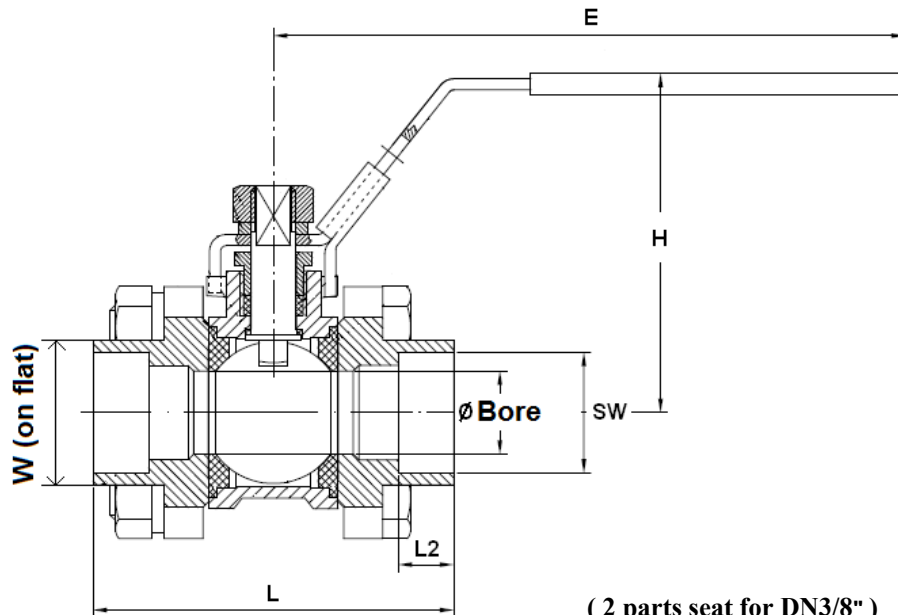
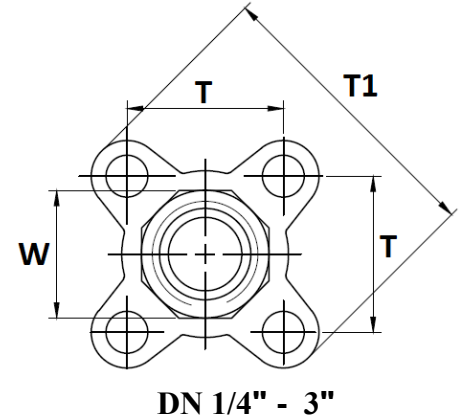
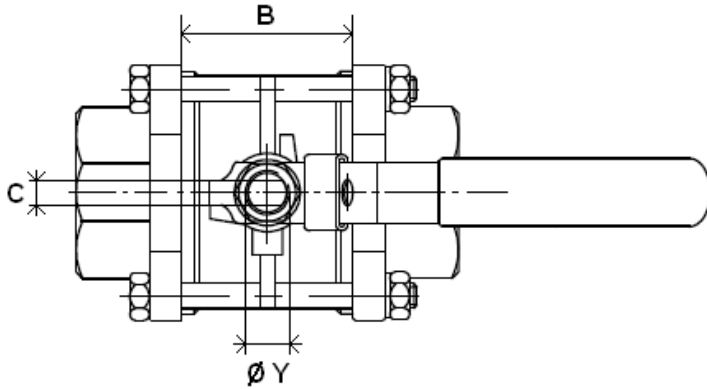

(2 parts seat for DN3/8\")

Stem size :

Ref.	DN	8	10	15	20	25	32	40	50	65	80	100	
792	Ø Bore	9.2	12.8	15	20	25	32	38	50	65	80	100	
	L	60	60	63	70	82	96	107	124	164.6	182.7	217.7	
	B	22	22	23.3	28	34	43	49	62.4	88.1	100.2	119.1	
	L2	10	10	10	13	13	13	13	16	16	16	19	
	E	136	136	136	136	165	165	190	190	300	300	335	
	H	52	52	63	68	79	88	97	108	128	140	172	
	Ø Y	8	8	8	8	10	10	12	12	14	14	20	
	S.W.	C	5	5	5	5	6.5	6.5	8.5	8.5	9.8	9.8	16
		T	27.2	27.2	31.8	40	45	53	63.3	78.8	98.3	116.6	200.5
		T1	51	51	59.5	71	80	91.5	106	132.8	164	194	231.5
		W	18	22	26	33	40	48	55	67	84.5	101	127
		SW	14.1	17.6	21.9	27.4	34.2	42.8	48.8	61.1	77	89.9	115.4
Weight (Kg)		0.33	0.33	0.49	0.64	0.96	1.37	2.2	3.75	6.85	10.2	20.5	

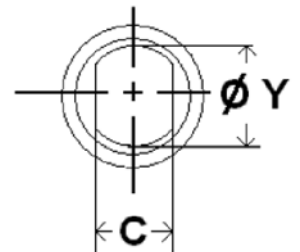

3 PIECES BALL VALVE PN63

SIZE SOCKET WELDING CARBON STEEL TYPES (in mm) REF. 798 :

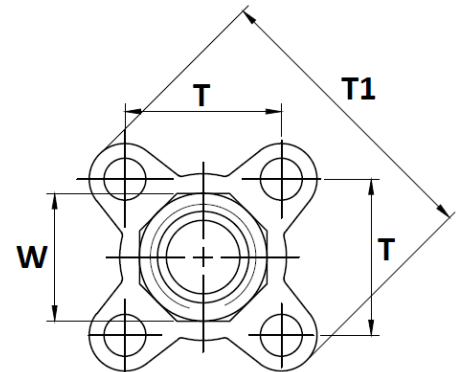
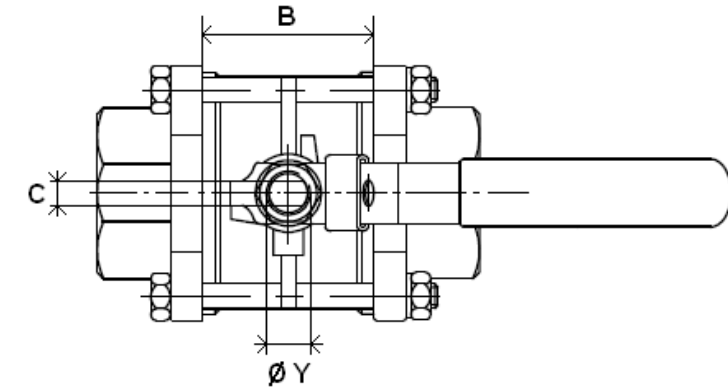

DN 1/4" - 3"

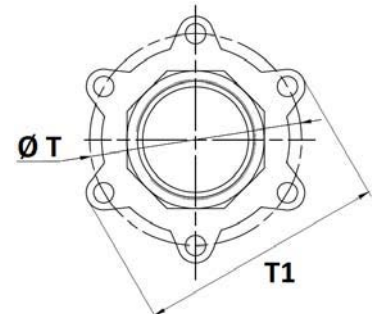
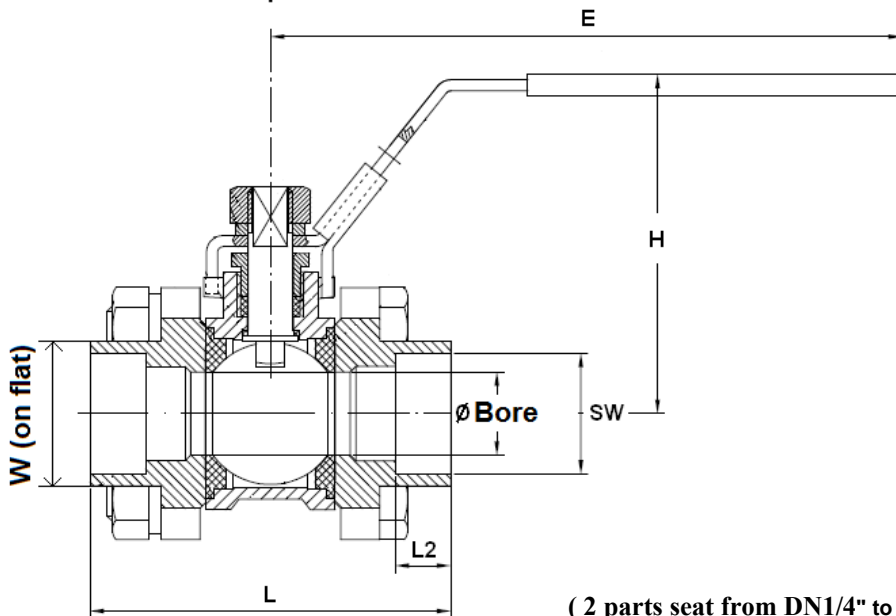

DN 4"

(2 parts seat from DN1/4" to 1 1/2")

Stem size :

Ref.	DN	8	10	15	20	25	32	40	50	65	80	100	
798	Ø Bore	9.2	12.8	15	20	25	32	38	50	65	80	100	
	L	59	60	65.5	76.5	86.2	103.1	118	131.5	174.5	192.7	239.6	
	B	20	22	23.3	30.8	37.8	47	57	68	96.1	108.2	136.1	
	L2	10	10	10	13	13	13	13	16	16	16	19	
	E	108	108	113	113	135	135	190	190	230	230	335	
	H	52	52	63	68	79	88	97	108	128	140	172	
	C	5	5	5	5	6.5	6.5	8.5	8.5	10	10	16	
	S.W.	Ø Y	8	8	8	8	10	10	12	12	14	14	20
		T	25	28	32	40	45	53	64	79	98	116	198
		T1	48	51	59.5	71	80	91.5	108	132.8	164	194	234
		W	20	22	26	33	40	48	55	67	87	101	130
		SW	14.1	17.6	21.9	27.4	34.2	42.8	48.8	61.1	77	89.9	115.4
		Weight (Kg)	0.33	0.33	0.52	0.78	1.08	1.64	2.78	4.27	8.2	13	26

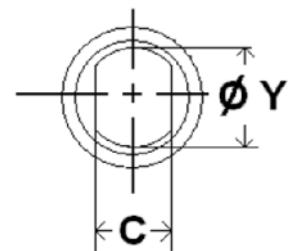

3 PIECES BALL VALVE PN63

STEM EXTENSION (in mm) :

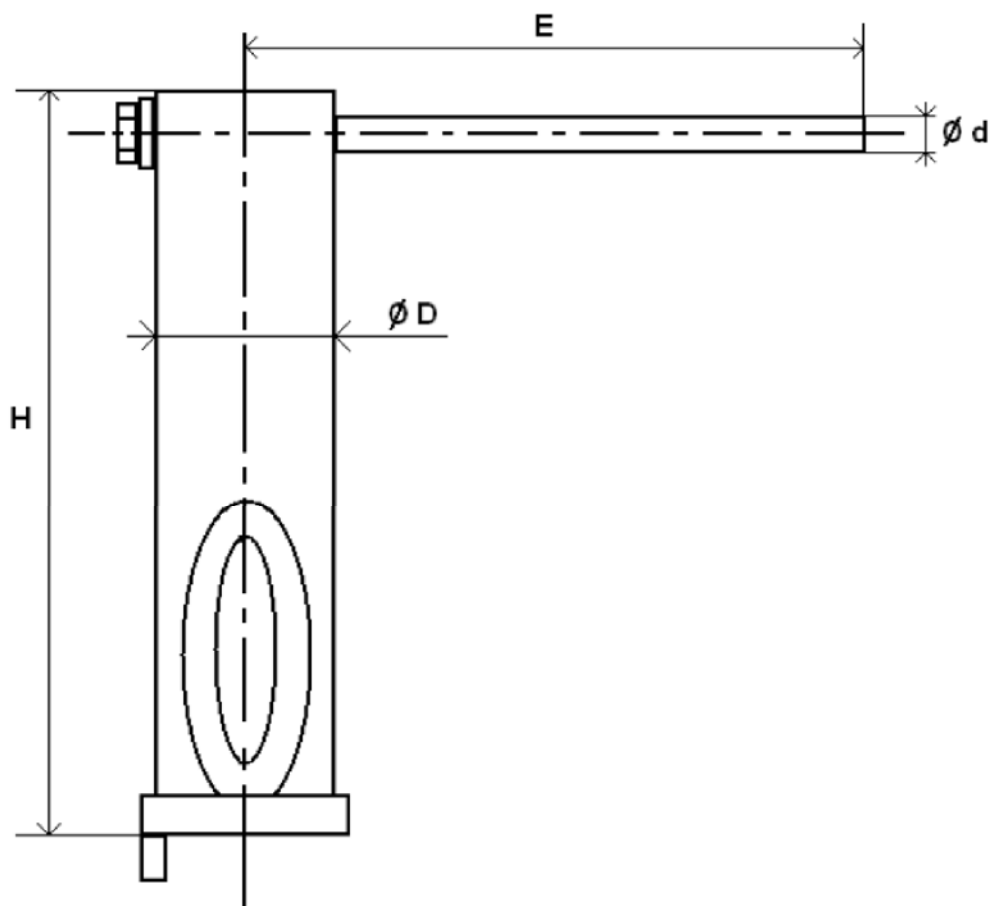

Ref.	DN	1/4"	3/8"	1/2"	3/4"	1"	1"1/4	1"1/2	2"
981060	H	125.5	125.5	125.5	125.5	125.5	125.5	127.5	127.5
	E	125	125	125	125	158	158	190	190
	Ø D	28	28	28	28	32	32	36	36
	Ø d	12	12	12	12	14	14	14	14
	Weight (Kg)	0.3	0.3	0.3	0.3	0.4	0.4	0.6	0.6

3 PIECES BALL VALVE PN63

TORQUE VALUES (In Nm without safety coefficient) :

DN	1/4"	3/8"	1/2"	3/4"	1"	1"1/4"	1"1/2"	2"	2"1/2"	3"	4"
TORQUE (Nm)	5	5	5	8	12.5	17	21	30	45	70	100

BOLT TIGHTENING TABLE (in Nm) :

DN	1/4"	3/8"	1/2"	3/4"	1"	1"1/4"	1"1/2"	2"	2"1/2"	3"	4"
TORQUE (Nm)	4	4	8	8	10	13	20	20	35	45	65

STANDARDS :

Fabrication according to ISO 9001 : 2008

DIRECTIVE 97/23/CE : CE N° 0035
 Risk Category III Module H

Pressure tests according to EN 12266-1, range A

Threaded BSP cylindrical ends according to ISO 228-1

Threaded NPT ends according to ANSI B1.20.1

ADVICE : Our opinion and our advice are not guaranteed and SFERACO shall not be liable for the consequences of damages. The customer must check the right choice of the products with the real service conditions.

3 PIECES BALL VALVE PN63

INSTALLATION AND MAINTENANCE

BEFORE INSTALLATION :

Pipe-line must be cleaned and free from residual of weldings, rubbish, shaving and every kind of extraneous materials. Pipe-line must be perfectly aligned and their support properly dimensioned so that there's no external constraint.

Check to use a produce compatible to the services conditions for the sealing of the threaded types.

To tighten the ends, use the appropriate tool.

Use the right bolt tightening so that the ends won't be damaged.

The welding of the ends for the SW and the BW types, must be done with the central part removed.

A gauge can be used to have the good length and alignment between the ends.

INSTALLATION OF THE CENTRAL PART

During the installation of the central part, tighten bolts according to the table below. Tighten bolts in cross.

BOLT TIGHTENING TABLE (in Nm) :

DN	1/4"	3/8"	1/2"	3/4"	1"	1"1/4"	1"1/2"	2"	2"1/2"	3"	4"
TORQUE (Nm)	4	4	8	8	10	13	20	20	35	45	65

CLEANING AND TESTS

Keep closed the valves during the cleaning operation so that there's no impurities between the ball and the body.

Tests under pressure must be done with a cleaned pipe-line.

Open partially the valve for tests. Pressure test do not exceed the valve specifications according to EN 12266-1.

MAINTENANCE

It's recommended to operate the valve twice (open and close) 1 to 2 times per year.

When intervention on the valve, be sure there's no pressure in the pipe-line, there's no fluid in it, and that it is isolated.

The temperature must be low enough to operate without risks.

If there's a corrosive fluid, inert installation before intervention.

When the valve is under pressure :

If there's a leakage between the body and the ends, tighten bolts according to the above table

If there's a leakage at the packing, tighten it slightly so that the leakage disappears.

MAINTENANCE OPERATION IN WORKSHOP

REPLACEMENT OF SEAT GASKETS AND PACKING.

The central part must be removed.

Turn the ball at 45° and removed the seat gaskets.

Operate the valve in closed position to removed the ball. Verify the surface of the ball has no impacts and no scores.

If there are important scores or impacts, replace the ball.

Clean inside the body valve and remove the impurities.

To replace the packing, remove the handle, unscrew the gland nut, extract the stem by the inside of the valve.

Clean the packing seat.

Reassemble thrust washer on stem, introduce stem by the inside of the valve, reassemble packing with packing nut, reassemble hand washer, hand nut and the handle.

Turn stem in closed position and insert the ball.

Then turn the ball in opened position and reassemble the seat.

Place the valve on the installation, tighten bolts according to the above table.

Then proceed to the tests in the same way that the first installation.