

3 PIECES BALL VALVE WITH ISO MOUNTING PAD PN 63



Size : DN 8 to 100 mm
Ends : Threaded BSP, NPT, Socket or Butt Welding
Min Temperature : -20°C
Max Temperature : + 180°C
Max Pressure : 63 Bars up to DN20
Specifications : ISO 5211 mounting pad
PTFE filled with 15% glass seat
Anti blow-out stem

Materials : Stainless Steel

3 PIECES BALL VALVE WITH ISO MOUNTING PAD PN 63

SPECIFICATIONS :

- Full bore
- Anti blow-out stem
- PTFE packing
- PTFE filled with 15% glass seat
- Locking device
- ISO 5211 mounting pad

USE :

Chemical and pharmaceutical industries, petrochemical industries
 Min and max Temperature Ts : -20°C to + 180°C
 Max Pressure Ps : 63 bars up to DN20, 40 bars from DN25 to 50, 25 bars from DN65 to 80 and 20 bars for DN100 (see graph under)

PRESSURE / TEMPERATURE GRAPH (STEAM AND COMPRESSED AIR EXCLUDED) :

Pressure (Bar)

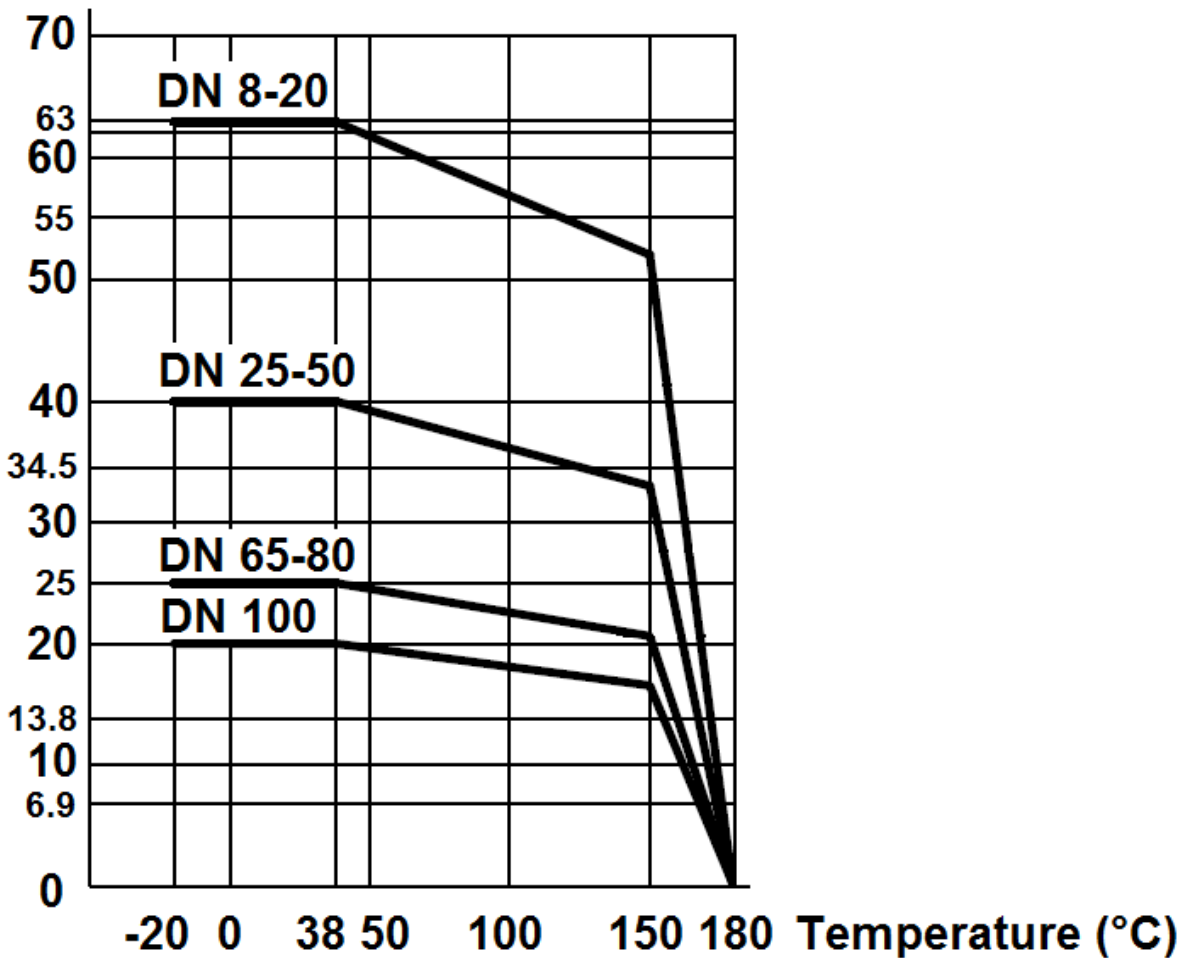

3 PIECES BALL VALVE WITH ISO MOUNTING PAD PN 63

RANGE :

- 3 pieces ball valve with ISO mounting pad female / female threaded BSP ends **Ref. 740**
- 3 pieces ball valve with ISO mounting pad female / female threaded NPT ends **Ref. 743**
- 3 pieces ball valve with ISO mounting pad Butt Welding ends **Ref. 741**
- ? 3 pieces ball valve with ISO mounting pad Socket Welding ends **Ref. 742**

MATERIALS :

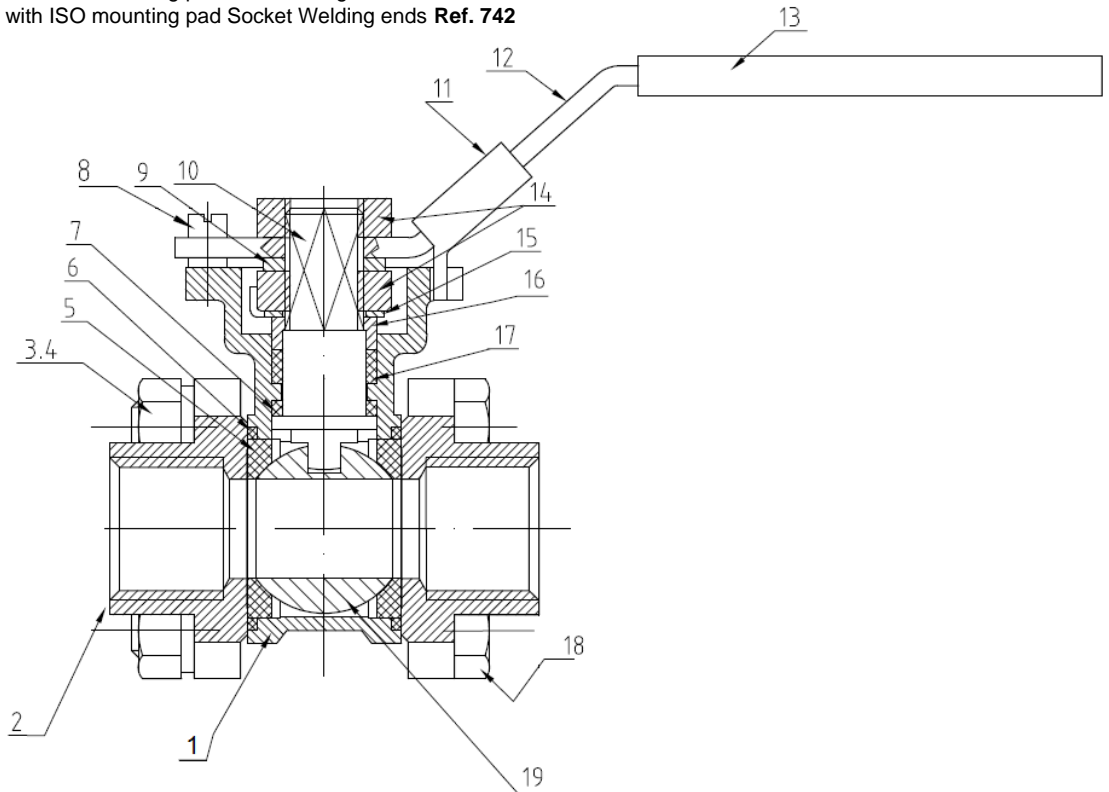

Item	Designation	Materials
1	Body	ASTM A351 CF8M
2	End cap	ASTM A351 CF8M
3	Bolt nut	SS 304
4	Bolt washer	SS 304
5*	Seat	PTFE + 15% glass
6*	Body seal	PTFE
7*	Stem seal	PTFE
8	Screw	SS 304
9	Thrust washer	SS 304
10	Stem	SS 316
11	Locking device	SS 304
12	Handle	SS 304
13	Plastic cover	Plastic
14	Stem nut	SS 304
15	Ring	SS 304
16	Gland ring	SS 304
17*	Packing	PTFE
18	Bolt	SS 304
19	Ball	ASTM A351 CF8M

(* : included in gaskets kit)

3 PIECES BALL VALVE WITH ISO MOUNTING PAD PN 63

SIZE THREADED TYPES 740 - 743 (in mm) :

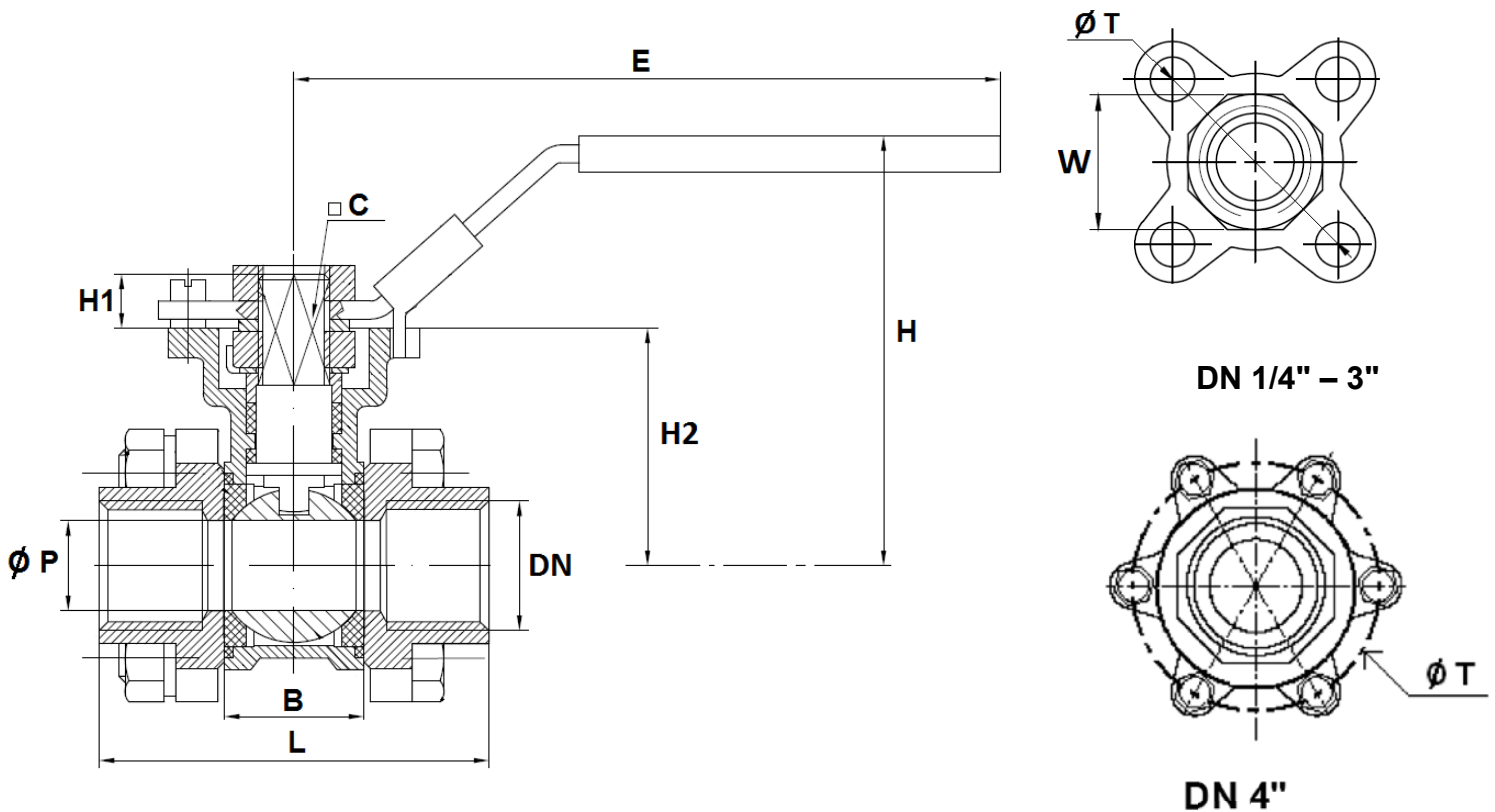

Ref.	DN	1/4"	3/8"	1/2"	3/4"	1"	1"1/4"	1"1/2"	2"	2"1/2"	3"	4"
740 / 743 Threaded	Ø P	9.2	12.8	15	20	25	32	38	50	65	80	100
	L	60	60	75	76.5	86.2	103	118	131.5	164.6	182.7	217.7
	B	22	22	25.5	30.8	37.8	47	57	68	88.1	100.2	119.1
	E	128	128	128	128	150	150	184	184	260	260	335
	H	63	64	71	76	90	95	108	117	148	155	180
	H1	8.5	8.5	9.5	9.5	11	11	15	15	20	20	20
	H2	31.3	31.3	38	43	48.5	54	67	76.2	105	111.5	136
	C	9	9	9	9	9	9	14	14	17	17	17
	Ø T	38.5	38.5	45	56.5	63.5	75	89.5	111.5	139	165	200.5
	W (on flat)	18	22	26	33	40	48	55	67	84.5	101	127
	Weight (Kg)	0.435	0.435	0.650	0.846	1.155	1.66	3.025	4.48	8.59	11.51	21

Stem size :

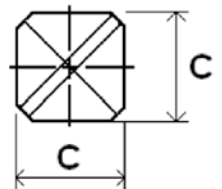

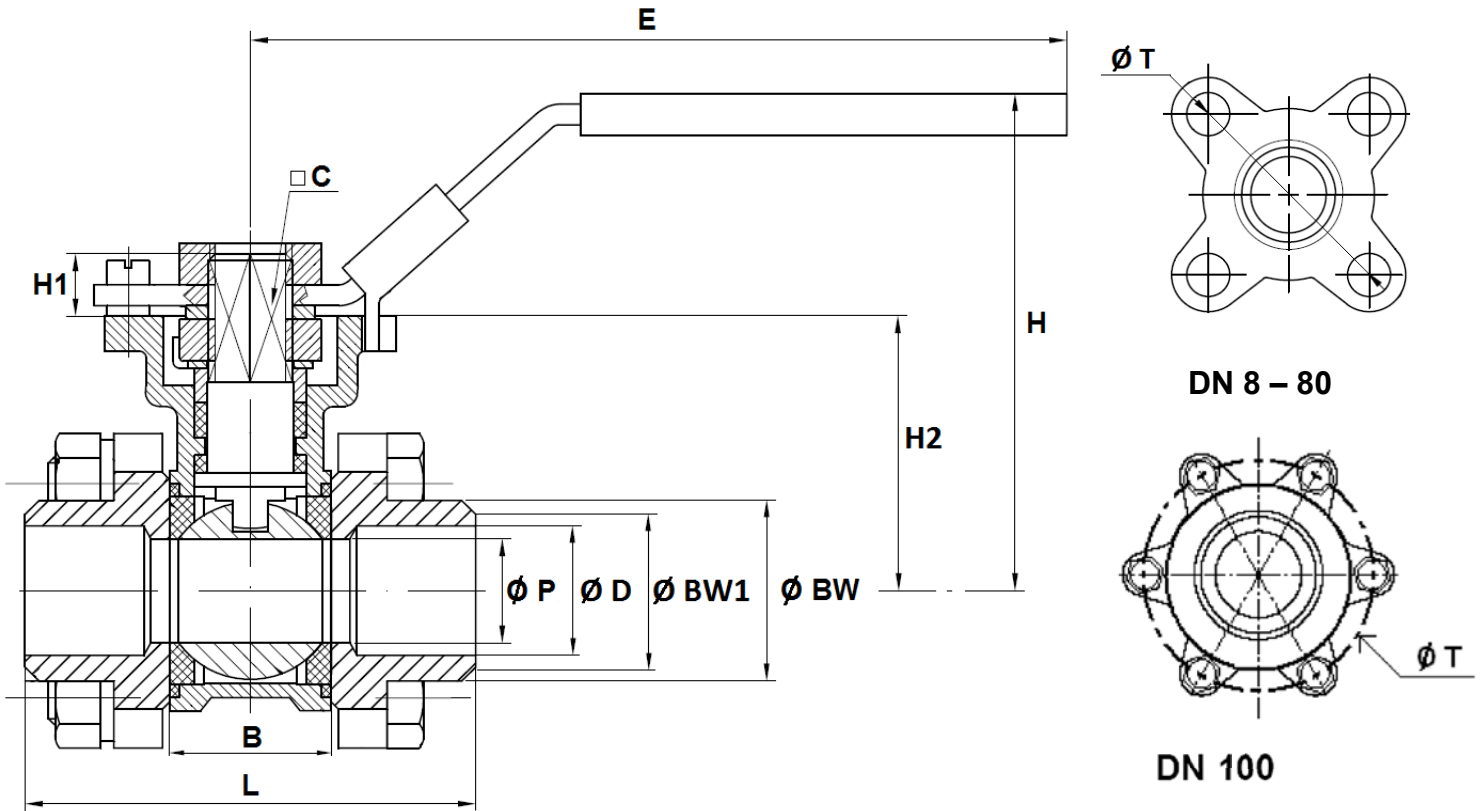
3 PIECES BALL VALVE WITH ISO MOUNTING PAD PN 63
SIZE WELDING B.W. TYPES 741 (in mm) :

Ref.	DN	8	10	15	20	25	32	40	50	65	80	100
741	Ø P	9.2	12.8	15	20	25	32	38	50	65	80	100
	Ø D	9.2	12.8	15	20	25	32	39.8	50	65	80	100
	L	60	60	67.7	76.5	86.2	103.1	118	131.5	162.6	180.7	221.7
	B	22	22	25.5	30.8	37.8	47	57	68	88.1	100.2	119.1
	E	128	128	128	128	150	150	184	184	260	260	335
	H	63	64	71	76	90	95	108	117	148	155	180
	H1	8.5	8.5	9.5	9.5	11	11	15	15	20	20	20
	H2	31.3	31.3	38	43	48.5	54	67	76.2	105	111.5	136
BW	C	9	9	9	9	9	9	14	14	17	17	17
	Ø T	38.5	38.5	45	56.5	63.5	75	89.5	111.5	139	165	200.5
	Ø BW	14	17.5	22	27.5	34	43	49	61	76.5	90	115
	Ø BW1	12	14.5	17	22.5	28.6	36	43	54	68	84	104
	Weight (Kg)	0.435	0.435	0.650	0.846	1.155	1.66	3.025	4.48	8.59	11.51	21

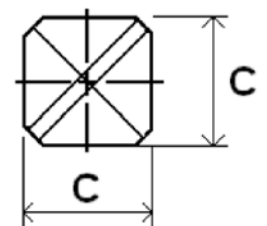
Stem size :

3 PIECES BALL VALVE WITH ISO MOUNTING PAD PN 63

SIZE WELDING S.W. TYPES 742 (in mm) :

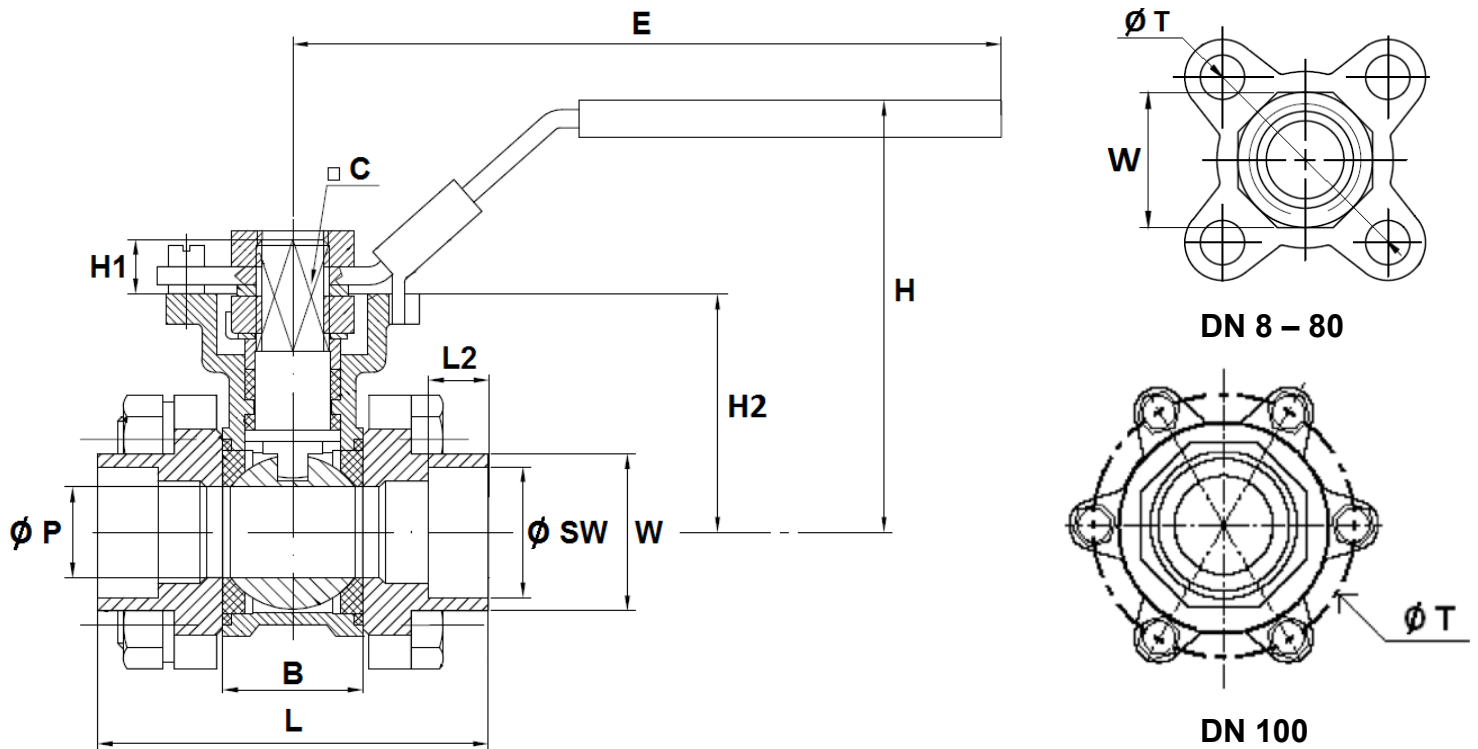

Ref.	DN	8	10	15	20	25	32	40	50	65	80	100
742	Ø P	9.2	12.8	15	20	25	32	38	50	65	80	100
	L	60	60	67.7	76.5	86.2	103.1	118	131.5	164.6	182.7	217.7
	B	22	22	25.5	30.8	37.8	47	57	68	88.1	100.2	119.1
	L2	10	10	10	13	13	13	13	16	16	16	19
	E	128	128	128	128	150	150	184	184	260	260	335
	H	63	64	71	76	90	95	108	117	148	155	180
	H1	8.5	8.5	9.5	9.5	11	11	15	15	20	20	20
SW	H2	31.3	31.3	38	43	48.5	54	67	76.2	105	111.5	136
	C	9	9	9	9	9	9	14	14	17	17	17
	Ø T	38.5	38.5	45	56.5	63.5	75	89.5	111.5	139	165	200.5
	W (on flat)	18	22	26	33	40	48	55	67	84.5	101	127
	Ø SW	14.1	17.6	21.9	27.4	34.2	42.8	48.8	61.1	77	89.9	115.4
	Weight(Kg)	0.435	0.435	0.650	0.846	1.155	1.66	3.025	4.48	8.59	11.51	21

Stem size :

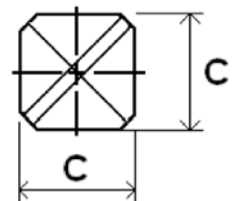

3 PIECES BALL VALVE WITH ISO MOUNTING PAD PN 63

ISO MOUNTING PAD AND STEM SIZE (in mm) :

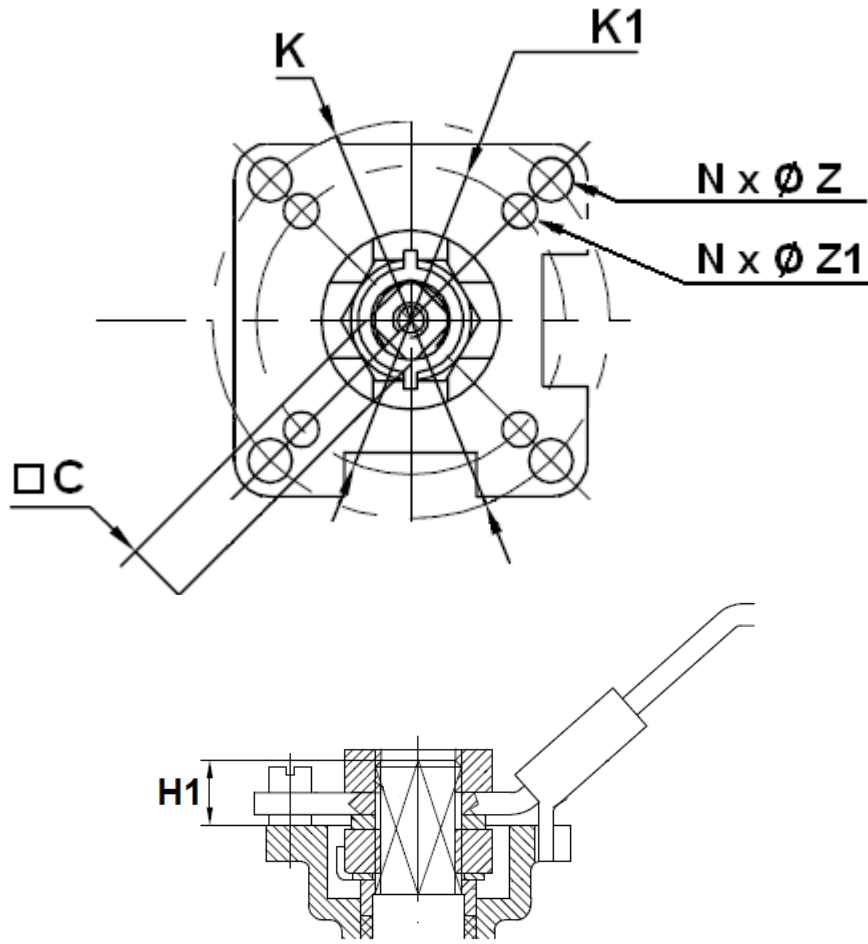

DN	8	10	15	20	25	32	40	50	65	80	100
C	9	9	9	9	9	9	14	14	17	17	17
H1	8.5	8.5	9.5	9.5	11	11	15	15	20	20	20
Ø K	50	50	50	50	50	50	70	70	102	102	102
ISO	F05	F05	F05	F05	F05	F05	F07	F07	F10	F10	F10
N x Ø Z	4 x 7	4 x 7	4 x 7	4 x 7	4 x 7	4 x 7	4 x 9	4 x 9	4 x 11	4 x 11	4 x 11
Ø K1	36	36	36	36	36	36	50	50	70	70	70
ISO 1	F03	F03	F03	F03	F03	F03	F05	F05	F07	F07	F07
N x Ø Z1	4 x 6	4 x 6	4 x 6	4 x 6	4 x 6	4 x 6	4 x 7	4 x 7	4 x 9	4 x 9	4 x 9

3 PIECES BALL VALVE WITH ISO MOUNTING PAD PN 63

FLOW COEFFICIENT Kvs (m³ / h):

DN	8	10	15	20	25	32	40	50	65	80	100
Kvs (m ³ / h)	10.7	20.7	28.46	50.70	79.20	128	183	316.6	535.60	811	1267.70

TORQUE VALUES (in Nm without safety coefficient) :

DN	8	10	15	20	25	32	40	50	65	80	100
Torque (Nm)	5	5	5	8	12.5	17	21	30	45	70	100

BOLT TIGHTENING TABLE (in Nm):

DN	8	10	15	20	25	32	40	50	65	80	100
Torque (Nm)	4	4	8	8	10	13	20	20	35	45	65

STANDARDS :

Fabrication according to ISO 9001 : 2008

DIRECTIVE 97/23/CE : CE N° 0035
 Risk category III Module H

Construction according EN 12516-2

Pressure tests according to API 598-04, Table 2-3

Threaded BSP cylindrical ends according to ISO 228-1

Threaded NPT ends according to ASME B1.20.1

ISO 5211 mounting pad

ADVICE : Our opinion and our advice are not guaranteed and SFERACO shall not be liable for the consequences of damages.
 The customer must check the right choice of the products with the real service conditions.

3 PIECES BALL VALVE WITH ISO MOUNTING PAD PN 63

INSTALLATION AND MAINTENANCE

BEFORE INSTALLATION :

Pipe-line must be cleaned and free from residual of weldings, rubbish, shaving and every kind of extraneous materials.
 Pipe-line must be perfectly aligned and their support properly dimensioned so that there's no external constraint.

Check to use a produce compatible to the services conditions for the sealing of the threaded types.
 To tighten the ends, use the appropriate tool.
 Use the right bolt tightening so that the ends won't be damaged.

The welding of the ends for the SW and the BW types, must be done with the central part removed.
 A gauge can be used to have the good length and alignment between the ends.

INSTALLATION OF THE CENTRAL PART

During the installation of the central part, tighten bolts according to the table below. Tighten bolts in cross.

BOLT TIGHTENING TABLE (in Nm) :

DN	8	10	15	20	25	32	40	50	65	80	100
Torque (Nm)	4	4	8	8	10	13	20	20	35	45	65

CLEANING AND TESTS

Keep closed the valves during the cleaning operation so that there's no impurities between the ball and the body.

Tests under pressure must be done with a cleaned pipe-line.

Open partially the valve for tests. Pressure test do not exceed the valve specifications according to EN 12266-1.

MAINTENANCE

It's recommended to operate the valve twice (open and close) 1 to 2 times per year.

When intervention on the valve, be sure there's no pressure in the pipe-line, there's no fluid in it, and that it is isolated.
 The temperature must be low enough to operate without risks.
 If there's a corrosive fluid, inert installation before intervention.

When the valve is under pressure :

If there's a leakage between the body and the ends, tighten bolts according to the above table

If there's a leakage at the packing, tighten it slightly so that the leakage disappears.

MAINTENANCE OPERATION IN WORKSHOP

REPLACEMENT OF SEAT GASKETS AND PACKING.

The central part must be removed.

Turn the ball at 45° and removed the seat gaskets.

Operate the valve in closed position to removed the ball. Verify the surface of the ball has no impacts and no scores.

If there are important scores or impacts, replace the ball.

Clean inside the body valve and remove the impurities.

To replace the packing, remove the handle, unscrew the gland nut, extract the stem by the inside of the valve.

Clean the packing seat.

Reassemble thrust washer on stem, introduce stem by the inside of the valve, reassemble packing with packing nut, reassemble hand washer, hand nut and the handle.

Turn stem in closed position and insert the ball.

Then turn the ball in opened position and reassemble the seat.

Place the valve on the installation, tighten bolts according to the above table.

Then proceed to the tests in the same way that the first installation.