

3 PIECES BALL VALVE WITH ISO MOUNTING PAD PN 63

armat
spol. s r.o.
MADE OF STAINLESS ...



**Lloyd's
Register**
PED 97/23/CE



Size : DN 8 to 100 mm
Ends : Threaded BSP , Socket or Butt Welding
Min Temperature : -30°C in S.S.and -20°C in carbon steel
Max Temperature : + 220°C
Max Pressure : 63 Bars up to DN50 , 40 Bars over
Specifications : ISO 5211 mounting pad
PTFE filled with S.S. seat
Anti blow-out stem
Atex

Materials : Carbon steel ou Stainless Steel

3 PIECES BALL VALVE WITH ISO MOUNTING PAD PN 63

SPECIFICATIONS :

Full bore
 Anti blow-out stem
 Special gland pack with elastic washer
 Antistatic device from DN8 to 32, double antistatic device (ball between body-stem and ball-stem) from DN40 to 100
 PTFE filled with stainless steel seat
 Locking device
 Blue handle cover possible
 ISO 5211 mounting pad

USE :

Chemical and pharmaceutical industries, petrochemical industries, hydraulic installation, compressed air
 Steam : 18 bars maximum
 Vacuum : 10^{-2} torr
 Min and max Temperature Ts : -30°C to + 220°C for stainless steel type **Ref. 747,748,749**
 Min and max Temperature Ts : -20°C to + 220°C for carbon steel type **Ref. 737,738,739**
 Max Pressure Ps : 63 bars up to DN50 and 40 bars over (see graph)

PRESSURE / TEMPERATURE GRAPH :

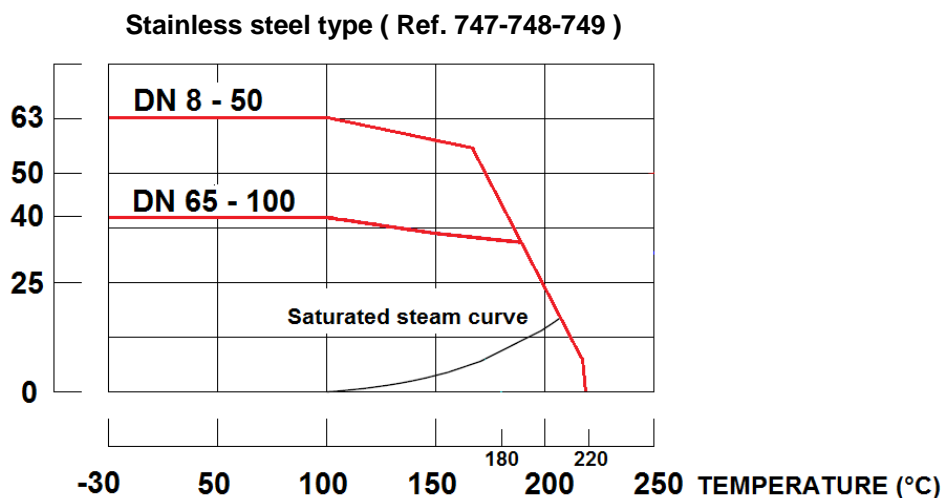
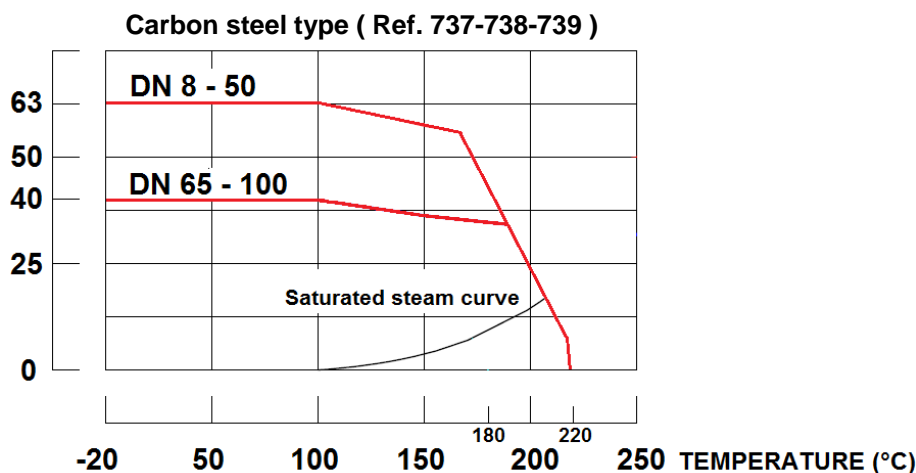

3 PIECES BALL VALVE WITH ISO MOUNTING PAD PN 63

RANGE :

Carbon steel body Ref. 737/738/739 from DN 8 to DN 100
 Stainless steel body Ref. 747/748/749 from DN 8 to DN 100
 Blue handle cover Ref. 9830432-9830436 from DN 8 to DN 100

ENDS :

Female / female threaded BSP Ref. 737/747
 Socket Welding Ref. 739/749
 Butt Welding Ref. 738/748

MATERIALS :

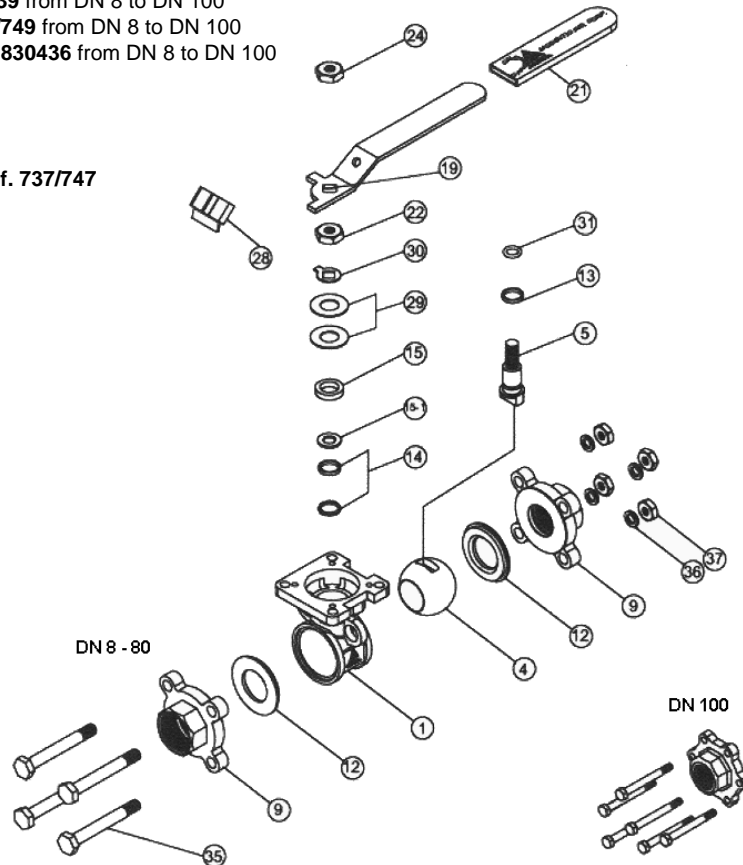

Item	Designation	Materials 737/738/739	Materials 747/748/749
1	Body	ASTM A216 WCB	ASTM A351 CF8M
4	Ball	ASTM A351 CF8M	
5	Stem	SS 316	
9	Ends	ASTM A216 WCB	ASTM A351 CF8M
12*	Seat	PTFE with 50% SS 316	
13*	Thrust washer	PTFE with 25% grafoil	
14*	Stem packing	PTFE with 25% grafoil	
15-1*	Packing Follower	PTFE with 15% grafoil	
15	Gland bush	SS 304	
19	Handle	SS 304	
21	Handle cover	Plastic	
22	Stem nut	SS 304	
24	Handle nut	SS 304	
28	Locking device	SS 304	
29	Elastic washer	SS 301	
30	Tab washer	SS 304	
31*	O-ring	FKM	
35	Body bolt	SS 304	
36	Bolt washer	SS 304	
37	Bolt nut	SS 304	

(* : included in gaskets kit)

3 PIECES BALL VALVE WITH ISO MOUNTING PAD PN 63

SIZE THREADED TYPES REF.737 / 747 (in mm) :

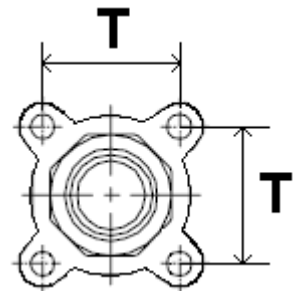
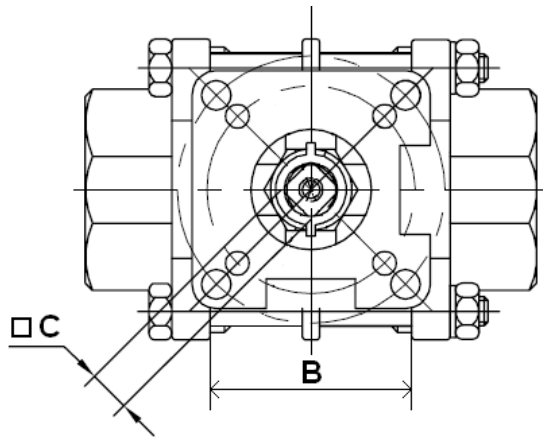

DN 1/4" – 3"

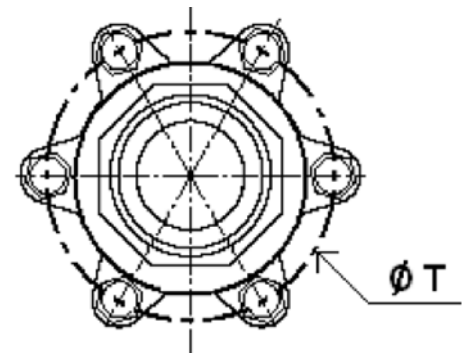
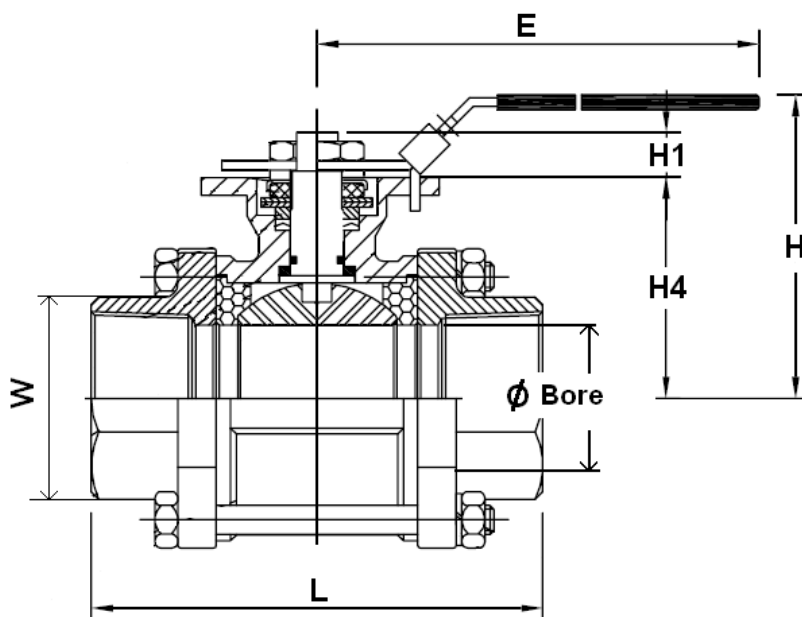

DN 4"

Stem size :

Ref.	DN	1/4"	3/8"	1/2"	3/4"	1"	1"1/4"	1"1/2"	2"	2"1/2"	3"	4"
737 / 747 Threaded	Ø Bore	11.5	12.5	15	20	25	32	38	50	65	80	100
	L	63.5	63.5	63.5	72.5	81	94.5	108	121.5	157.5	190	225
	B	22.5	22.5	22.5	27.5	34	42.5	52	63.5	85.5	102	129
	E	112	112	112	112	136	185	197.9	197.9	264	264	325
	H	73	73	73	80.8	90.5	98.7	115.3	124	155	208.5	216.7
	H1	8.5	8.5	8.5	8.5	11.4	11.4	14	13.7	18	18	23
	H4	37	37	37	45	53.5	59	74.8	83.5	108.8	118.3	153.8
	C	9	9	9	9	9	9	14	14	17	17	17
	T	31	31	31	35	41	49	59	71	91	107	195
	W (on flat)	28	28	28	34	42	50	58	70	88	103	128
	Weight (Kg)	0.64	0.62	0.58	0.75	1.03	1.62	2.5	3.7	7.8	11.3	22

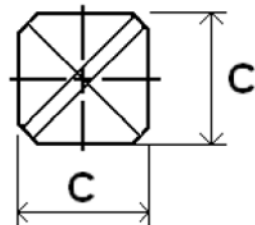

3 PIECES BALL VALVE WITH ISO MOUNTING PAD PN 63

SIZE WELDING B.W. TYPES REF. 738 / 748 (in mm) :

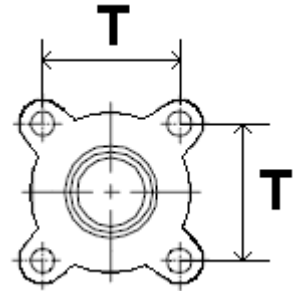
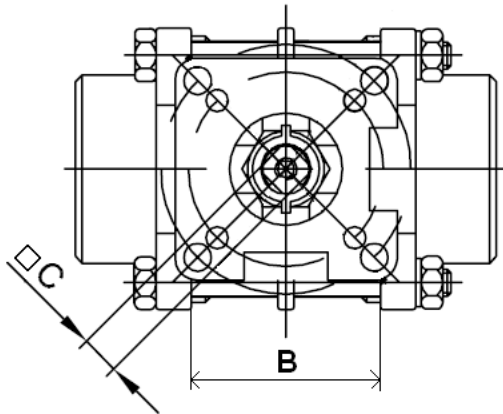

DN 8 – 80

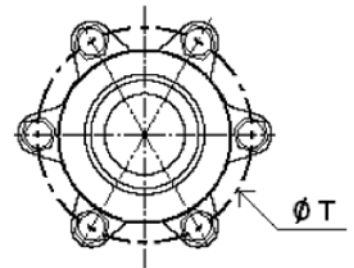
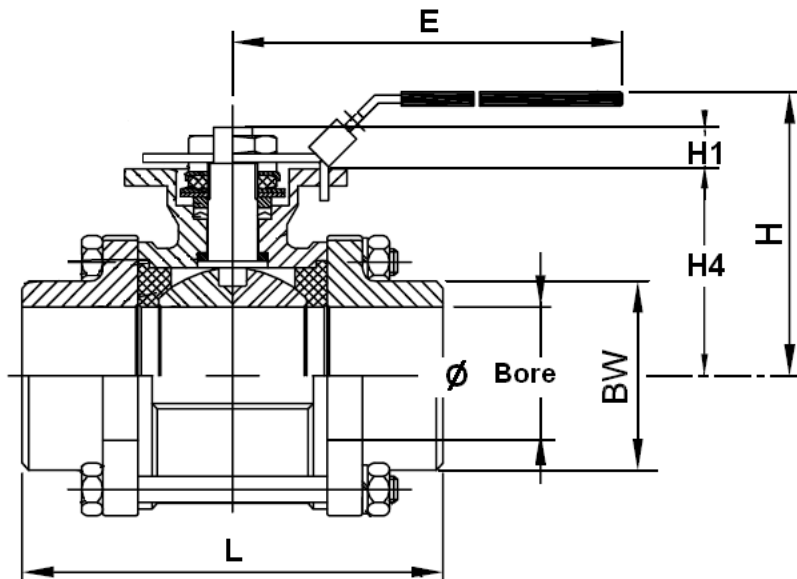

DN 100

Stem size :

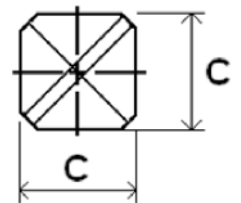

Ref.	DN	8	10	15	20	25	32	40	50	65	80	100
738 / 748	Ø Bore	11.5	12.5	15	20	25	32	38	50	65	80	100
	L	63.5	63.5	63.5	72.5	81	94.5	108	121.5	157.5	190	225
	B	22.5	22.5	22.5	27.5	34	42.5	52	63.5	85.5	102	129
	E	112	112	112	112	136	185	197.9	197.9	264	264	325
	H	73	73	73	80.8	90.5	98.7	115.3	124	155	208.5	216.7
	H1	8.5	8.5	8.5	8.5	11.4	11.4	14	13.7	18	18	23
	H4	37	37	37	45	53.5	59	74.8	83.5	108.8	118.3	153.8
	C	9	9	9	9	9	9	14	14	17	17	17
BW	T	31	31	31	35	41	49	59	71	91	107	195
	Ø BW	13.7	17.1	21.3	26.7	33.4	42.2	48.3	60.3	73	88.9	114.3
	Weight (Kg)	0.55	0.58	0.57	0.71	1	1.56	2.5	3.6	7.6	10.98	21

3 PIECES BALL VALVE WITH ISO MOUNTING PAD PN 63

SIZE WELDING S.W. TYPES REF. 739 / 749 (in mm) :

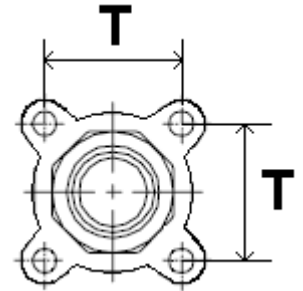
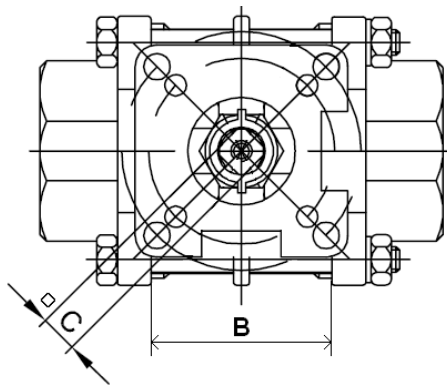

DN 8 – 80

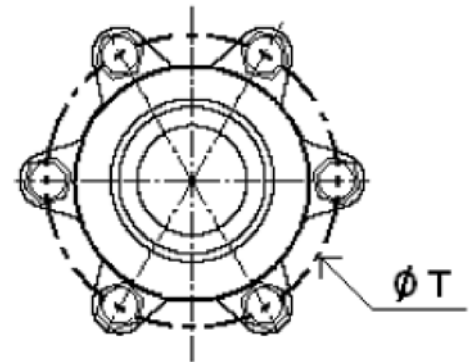
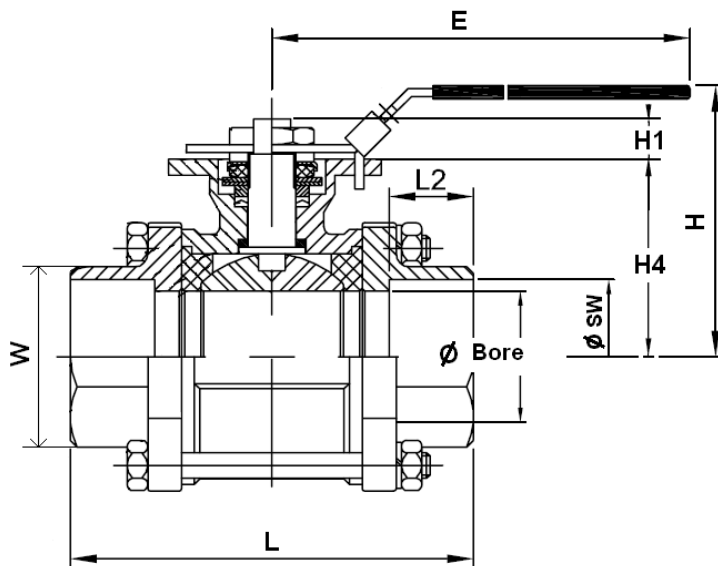

DN 100

Stem size :

Ref.	DN	8	10	15	20	25	32	40	50	65	80	100
739 / 749	Ø Bore	11.5	12.5	15	20	25	32	38	50	65	80	100
	L	63.5	63.5	63.5	72.5	81	94.5	108	121.5	157.5	190	225
	B	22.5	22.5	22.5	27.5	34	42.5	52	63.5	85.5	102	129
	L2	10	10	10	13	13	13	13	16	16	16	22
	E	112	112	112	112	136	185	197.9	197.9	264	264	325
	H	73	73	73	80.8	90.5	98.7	115.3	124	155	208.5	216.7
	H1	8.5	8.5	8.5	8.5	11.4	11.4	14	13.7	18	18	23
	H4	37	37	37	45	53.5	59	74.8	83.5	108.8	118.3	153.8
	C	9	9	9	9	9	9	14	14	17	17	17
	T	31	31	31	35	41	49	59	71	91	107	195
SW	W (on flat)	28	28	28	34	42	50	58	70	88	103	128
	Ø SW	14.2	17.5	21.8	27.4	34.1	42.7	49	61	77	90.2	115.3
	Weight (Kg)	0.64	0.62	0.58	0.74	1.03	1.62	2.5	3.67	7.7	10.98	21

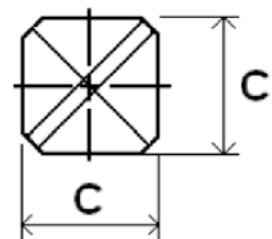

3 PIECES BALL VALVE WITH ISO MOUNTING PAD PN 63

ISO MOUNTING PAD AND STEM SIZE (in mm) :

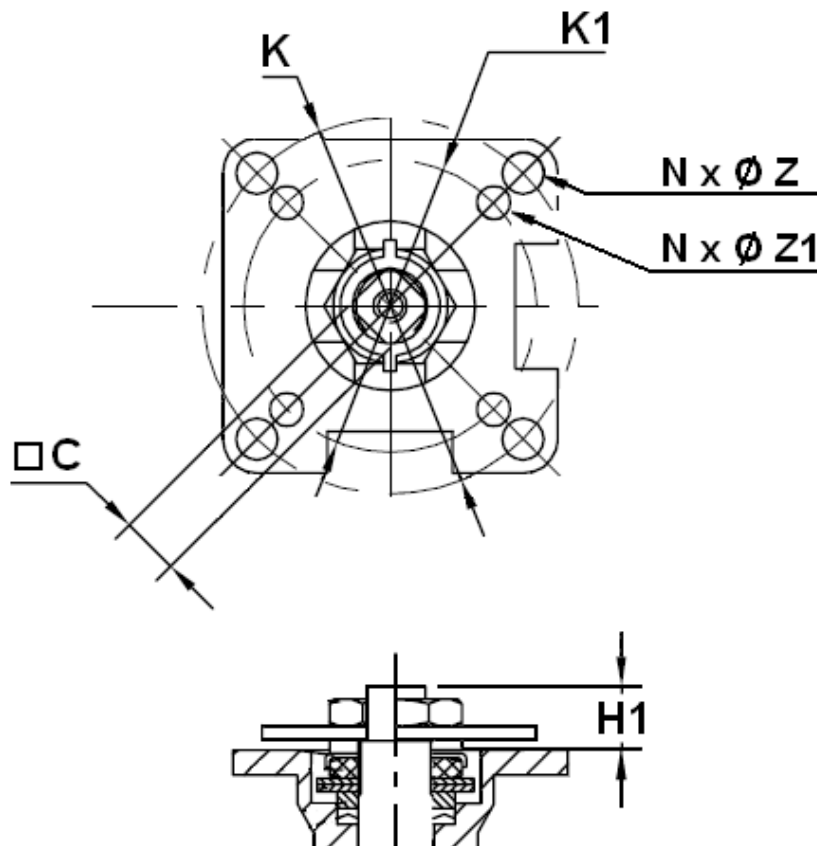

DN	1/4"	3/8"	1/2"	3/4"	1"	1"1/4	1"1/2	2"	2"1/2	3"	4"
C	9	9	9	9	9	9	14	14	17	17	17
H1	8.5	8.5	8.5	8.5	11.4	11.4	14	13.7	18	18	23
Ø K	50	50	50	50	50	50	70	70	102	102	102
ISO	F05	F05	F05	F05	F05	F05	F07	F07	F10	F10	F10
N x Ø Z	4 x 7	4 x 7	4 x 7	4 x 7	4 x 7	4 x 7	4 x 9	4 x 9	4 x 11	4 x 11	4 x 11
Ø K1	36	36	36	36	36	36	50	50	70	70	70
ISO 1	F03	F03	F03	F03	F03	F03	F05	F05	F07	F07	F07
N x Ø Z1	4 x 6	4 x 6	4 x 6	4 x 6	4 x 6	4 x 6	4 x 7	4 x 7	4 x 9	4 x 9	4 x 9

3 PIECES BALL VALVE WITH ISO MOUNTING PAD PN 63

TORQUE VALUES (in Nm without safety coefficient) :

DN	1/4"	3/8"	1/2"	3/4"	1"	1"1/4	1"1/2	2"	2"1/2	3"	4"
Torque	7.6	7.6	7.6	14.5	21	25	35	60	80	88	190

BOLT TIGHTENING TABLE (in Nm):

DN	1/4"	3/8"	1/2"	3/4"	1"	1"1/4	1"1/2	2"	2"1/2	3"	4"
Torque (Nm)	6.9	6.9	6.9	9.8	9.8	11.8	15.7	20.6	54.9	73.5	94.1

FLOW COEFFICIENT Kvs (M3 / h):

DN	1/4"	3/8"	1/2"	3/4"	1"	1"1/4	1"1/2	2"	2"1/2	3"	4"
Kvs (m3/h)	17.2	21	31.3	57.9	94.3	157.9	227.9	414.8	720.2	1091	1754

STANDARDS :

Fabrication according to ISO 9001 : 2008

DIRECTIVE 97/23/CE : CE N° 0038
 Risk category III Module H

Construction according EN 12516

Designing according to ASME B16.34

Pressure tests according to EN 12266-1, rate A

Threaded cylindrical BSP ends according to ISO 228-1

ISO 5211 mounting pad

ATEX Group II Category 2 G/2D Zone 1 & 21 Zone 2 & 22 (optional marking)

ADVICE : Our opinion and our advice are not guaranteed and SFERACO shall not be liable for the consequences of damages.
 The customer must check the right choice of the products with the real service conditions.

3 PIECES BALL VALVE WITH ISO MOUNTING PAD PN 63

INSTALLATION AND MAINTENANCE

BEFORE INSTALLATION :

Pipe-line must be cleaned and free from residual of weldings, rubbish, shaving and every kind of extraneous materials.
 Pipe-line must be perfectly aligned and their support properly dimensioned so that there's no external constraint.

Check to use a produce compatible to the services conditions for the sealing of the threaded types.
 To tighten the ends, use the appropriate tool.
 Use the right bolt tightening so that the ends won't be damaged.

The welding of the ends for the SW and the BW types, must be done with the central part removed.
 A gauge can be used to have the good length and alignment between the ends.

INSTALLATION OF THE CENTRAL PART

During the installation of the central part, tighten bolts according to the table below. Tighten bolts in cross.

BOLT TIGHTENING TABLE (in Nm) :

DN	1/4"	3/8"	1/2"	3/4"	1"	1"1/4	1"1/2	2"	2"1/2	3"	4"
Torque (Nm)	6.9	6.9	6.9	9.8	9.8	11.8	15.7	20.6	54.9	73.5	94.1

CLEANING AND TESTS

Keep closed the valves during the cleaning operation so that there's no impurities between the ball and the body.

Tests under pressure must be done with a cleaned pipe-line.

Open partially the valve for tests. Pressure test do not exceed the valve specifications according to EN 12266-1.

MAINTENANCE

It's recommended to operate the valve twice (open and close) 1 to 2 times per year.

When intervention on the valve, be sure there's no pressure in the pipe-line, there's no fluid in it, and that it is isolated.
 The temperature must be low enough to operate without risks.
 If there's a corrosive fluid, inert installation before intervention.

When the valve is under pressure :

If there's a leakage between the body and the ends, tighten bolts according to the above table

If there's a leakage at the packing, tighten it slightly so that the leakage disappears.

MAINTENANCE OPERATION IN WORKSHOP

REPLACEMENT OF SEAT GASKETS AND PACKING.

The central part must be removed.

Turn the ball at 45° and removed the seat gaskets.

Operate the valve in closed position to removed the ball. Verify the surface of the ball has no impacts and no scores.

If there are important scores or impacts, replace the ball.

Clean inside the body valve and remove the impurities.

To replace the packing, remove the handle, unscrew the gland nut, extract the stem by the inside of the valve.

Clean the packing seat.

Reassemble thrust washer on stem, introduce stem by the inside of the valve, reassemble packing with packing nut, reassemble hand washer, hand nut and the handle.

Turn stem in closed position and insert the ball.

Then turn the ball in opened position and reassemble the seat.

Place the valve on the installation, tighten bolts according to the above table.

Then proceed to the tests in the same way that the first installation.