

3 PIECES BALL VALVE FIRE SAFE ADLER TYPE FP3

armat
spol. s r.o.
MADE OF STAINLESS ...



Lloyd's Register
PED 97/23/CE



FIRE SAFE
ISO 10497



- Size :** DN 8 to 100 mm
- Ends :** Threaded BSP or NPT, B.W. or S.W.
- Min Temperature :** - 28°C
- Max Temperature :** + 200°C
- Max Pressure :** 20 to 100 Bars according to DN
- Specifications :** With ISO 5211 mounting pad
Fire safe ISO 10497
Full bore
Atex

3 PIECES BALL VALVE FIRE SAFE ADLER TYPE FP3

SPECIFICATIONS :

Full bore
 Anti blow-out stem
 With ISO 5211 mounting pad
 3 pieces type
 Double antistatic device
 Fire safe ISO 10497 (up to DN80), ISO-FT marking
 Fugitive emissions according to ISO 15848-1 : 2003 Class A
 3 PTFE filled with 15% graphite chevrons rings on stem
 Packing with elastic rings
 Polyamid epoxy painting blue color RAL5012, 35 μ thickness for carbon steel types

USE :

Chemical and pharmaceutical industries, petrochemical industries, hydraulic installation, compressed air
 Min and max Temperature Ts : - 28°C to + 200°C
 Max pressure Ps :

DN	8	10	15	20	25	32	40	50	65	80	100
Ps (Bars)	100	100	64	64	40	40	40	40	25	25	20

Vacuum : 10⁻⁵ torr
 Compressed air (ambient temperature) : 8 bars up to DN50, 6 bars from DN65 to 100
 Steam : 6 bars up to DN50, 3 bars from DN65 to 100

RANGE :

Carbon steel body, threaded BSP (NPT on request), BW or SW **Ref. 712** from DN 8 to DN 100
 Stainless steel body, threaded BSP (NPT on request), BW or SW **Ref. 713** from DN 8 to DN 100
 Possible with IP67 gear box **Ref. 9830260 à 262** from DN 15 to DN 100

ACCESSORIES AND OPTIONS :

Locking device **Ref. 9830140 to 9830145** from DN 8 to DN 100
 Stainless steel handle **Ref. 9830170 to 9830175** from DN 8 to DN 100
 Steel oval handle **Ref. 9830270 to 9830272** from DN 8 to DN 32
 Stainless steel oval handle
 Stainless steel bolting
 Carbon steel stem extension 100 mm **Ref. 9830273 to 9830277** from DN 8 to DN 100
 Stainless steel stem extension 100 mm **Ref. 9830193 to 9830197** from DN 8 to DN 100
 Deadman **Ref. 9830160 to 9830165** from DN 15 to DN 50
 Dry cleaned oxygen **Ref. 9830150 to 9830155** from DN 8 to DN 100
 Standard dry cleaned
 Seat PTFE filled with glass, graphite, stainless steel or metal
 Pocket less seat PTFE or PTFE filled with glass
 Specials coated
 Hole in the ball for overpressure device
 Double o ring on stem

ENDS :

Threaded female BSP
 Threaded female NPT (on request)
 Butt Welding ends
 Socket Welding ends

3 PIECES BALL VALVE FIRE SAFE ADLER TYPE FP3

MATERIALS :

PACKING GASKETS :

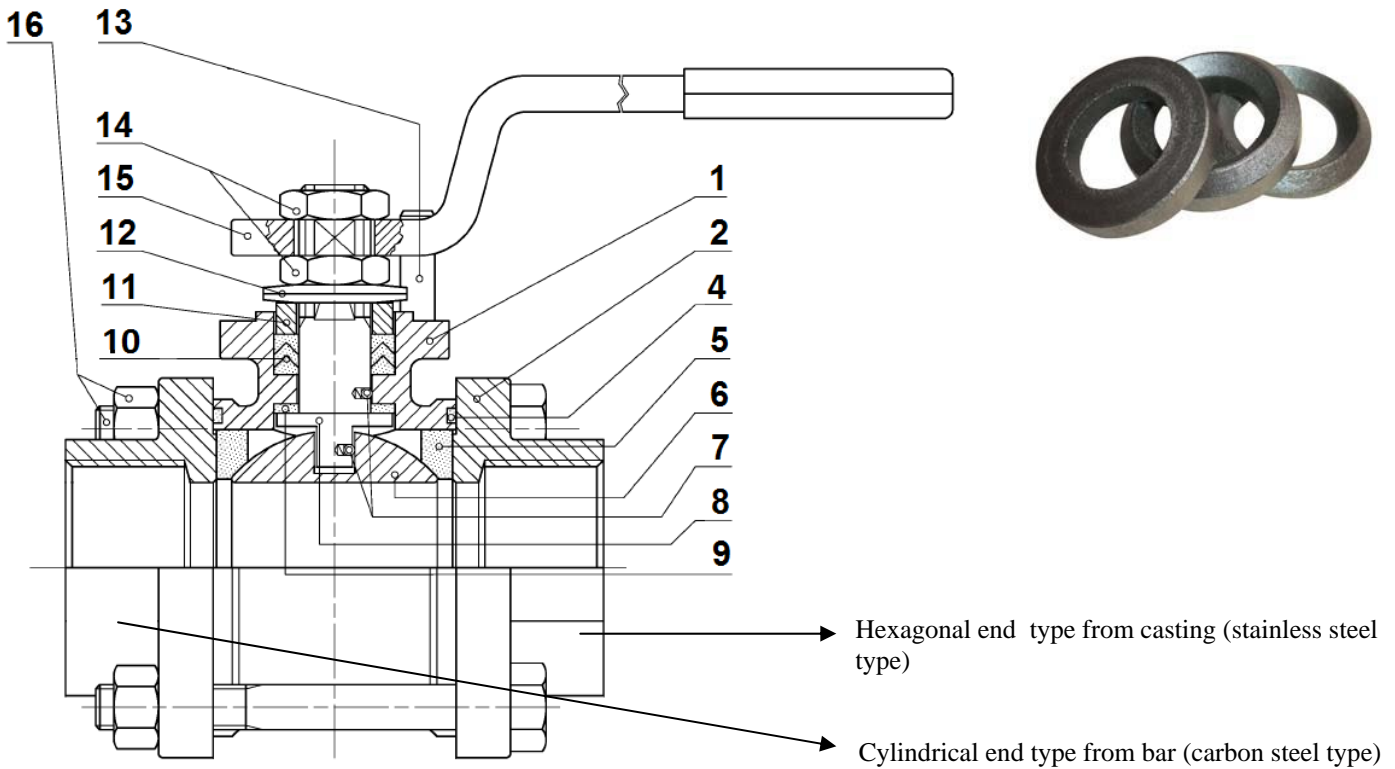

Item	Designation	Materials Ref. 712	Materials Ref. 713
1	Body	ASTM A216 WCB	ASTM A351 CF8M
2	Ends	A105	ASTM A351 CF8M (CF3M for BW type)
4*	Body gasket	PTFE	
5*	Seat	PTFE	
6	Ball	ASTM A351 CF3	ASTM A351 CF3M
7	Double antistatic device	ASTM A479 S31600	
8	Stem DN 15 - 32	ASTM A182 F 316 L	
8	Stem DN 40 – 100	ASTM A182 F 304 L	ASTM A182 F 316 L
9*	Stem gasket	PTFE	
10*	Chevron packing	PTFE filled with 15% graphite	
11	Gland follower	ASTM A479 S31600	
12	Elastic ring	C72 / 50 Cr V4	
13	Pin	UNI 3740 – 8.8	
14	Nut	UNI 3740-6S	
15	Handle	UNI 5946 Fe 37	
16	Bolting DN 8 – DN 32	UNI 3740 – 8.8	UNI 3723/8-A2/70
16	Bolting DN 40 – DN 100	UNI 3740 – 8.8	

(* : Included in gaskets kit)

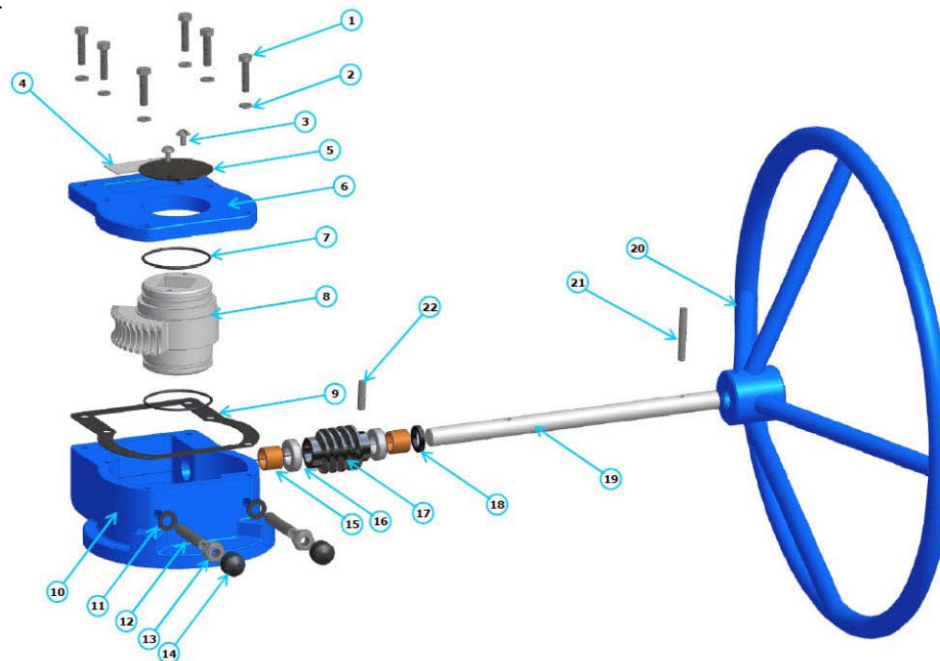
3 PIECES BALL VALVE FIRE SAFE ADLER TYPE FP3
GEARBOX MATERIALS :

Item	Designation	Materials Ref. 9830260 to 9830265
1	Box screw	DIN 933 class 8.8
2	Washer	C72
3	Indicator screw	DIN 86 class A2
4	ID plate	Steel S235 JR
5	Indicator	Steel S235 JR
6	Cover	Ductile iron EN GJS-400-15
7	O ring	NBR 70 Shore A
8	Wheel	Ductile iron EN GJS-500-7
9	Cover gasket	SL509AT
10	Box	Ductile iron EN GJS-400-15
11	Gasket	NBR 70 Shore A
12	Adjusting bolt	DIN 915 class 12.9
13	Nut	DIN 934 class 8G
14	Bolt cap	NBR 70 Shore A
15	Bushing	G Cu Sn10
16	Axial ball bearing	-
17	Worm	C45 + NiP
18	Gasket	NBR 70 Shore A
19	Input shaft	C45 + NiP
20	Handwheel	Steel S235 JR
21	Dowell pin	DIN 7 Class A2
22	Dowell pin	DIN 7 Class A2

3 PIECES BALL VALVE FIRE SAFE ADLER TYPE FP3

VALVES SIZE (in mm):

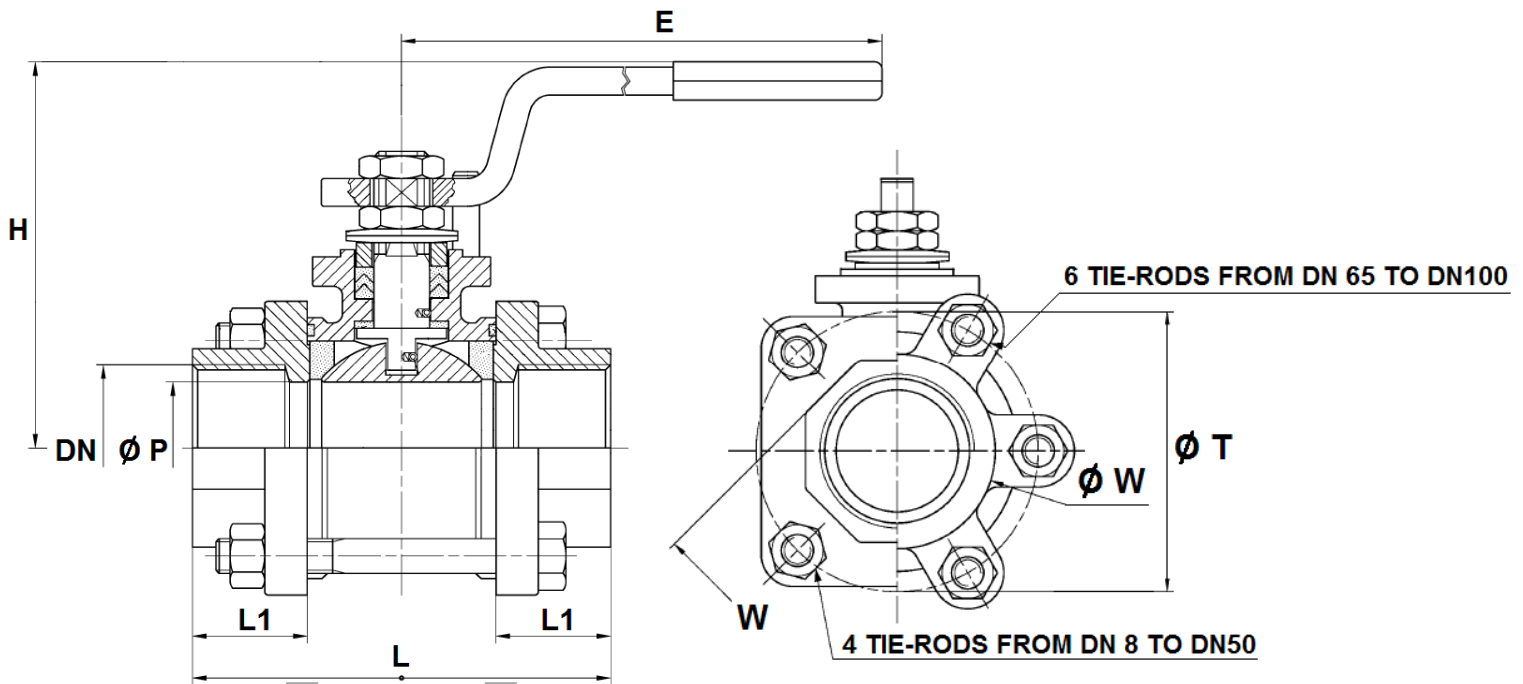

Ref.	DN	8	10	15	20	25	32	40	50	65	80	100
712 / 713	Ø P	10	10	15	19	25	30	38	51	64	76	101
	L	50	60	75	80	90	110	120	140	185	205	240
	L1	15.1	20.1	24.5	25.7	26.5	32.7	33.2	34.75	50.6	53.4	60
	E	120	120	145	145	185	185	280	280	370	370	470
	H	46	46	66	68	85	91	106	116	140	148	174
	Ø T	34.6	34.6	43.1	49.2	60.8	67.9	84	101.8	123	143	176
	W	12	22	26	32	38	47	54	66	82	95.5	122
	Weight (Kg)	0.3	0.35	0.75	0.85	1.35	1.75	3.3	4.9	11	15	23.5

3 PIECES BALL VALVE FIRE SAFE ADLER TYPE FP3

STEM AND ISO MOUNTING PAD SIZE (in mm) :

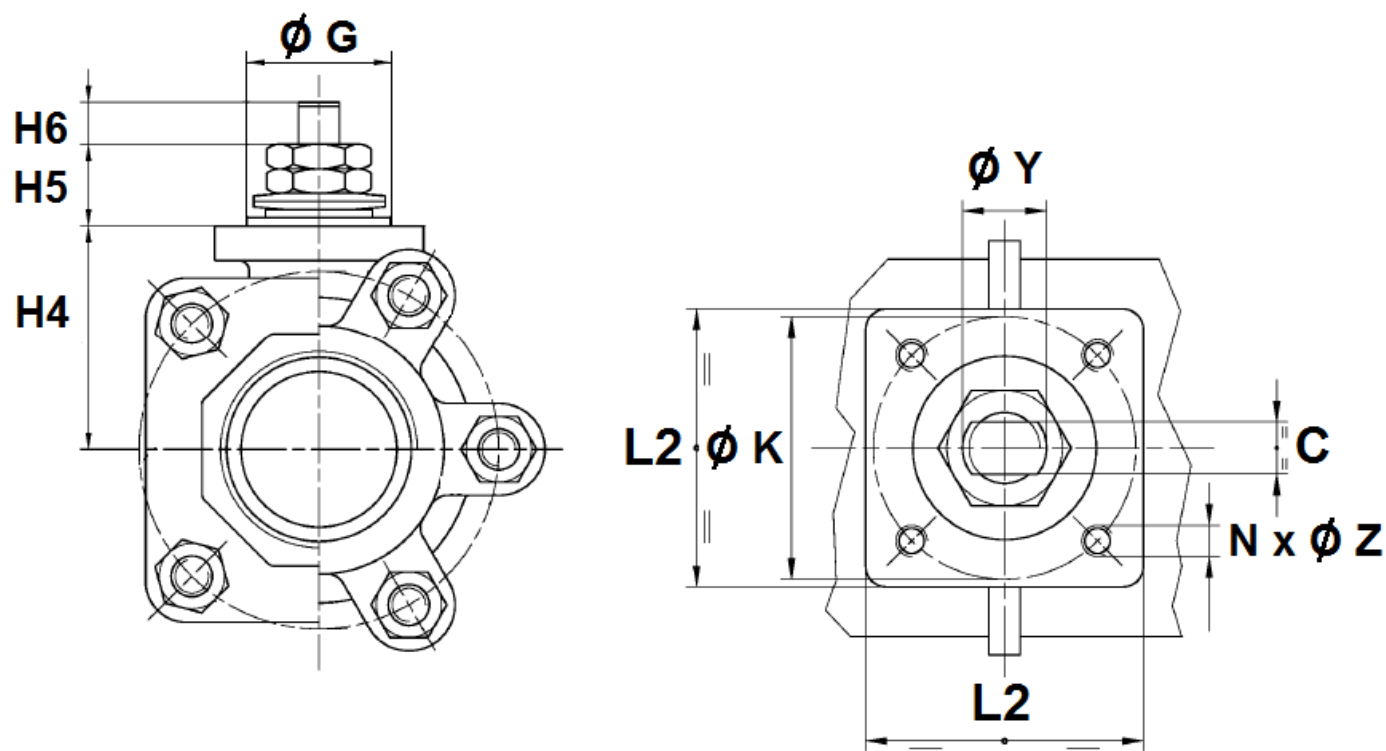

DN	8	10	15	20	25	32	40	50	65	80	100
H4	22.2	22.2	32.5	35	41	45.5	53	60.5	77.5	86	99.5
H5	7	7	8	8	17	17	20	20	23	23	26
H6	6	6	7	7	10	10	15	15	17	17	17
C	5	5	6	6	8	8	10	10	14	14	18
Ø Y	8	8	10	10	12	12	16	16	22	22	30
Ø K	36	36	36	36	36	36	50	50	70	70	70
ISO	F03	F03	F03	F03	F03	F03	F05	F05	F07	F07	F07
N x Ø Z	4 x M5	4 x M5	4 x M5	4 x M5	4 x M5	4 x M5	4 x M6	4 x M6	4 x M8	4 x M8	4 x M8
Ø G	25	25	25	25	25	25	35	35	55	55	55
L2	33	33	36	36	36	36	51	51	65	65	70

3 PIECES BALL VALVE FIRE SAFE ADLER TYPE FP3

Butt Welding ends size (in mm) :

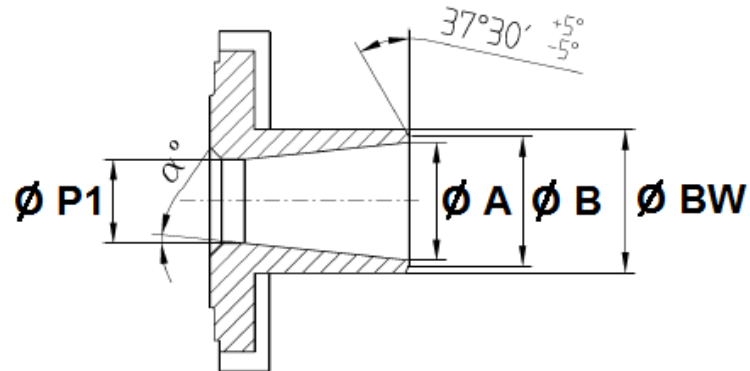

DN	8	10	15	20	25	32	40	50	65	80	100
$\varnothing BW$	14	18	22	28	34	42.2	49	61	77	90	115
$\varnothing P1$	10	10	15	20	25	30	40	50	65	80	100
$\varnothing A$	10	13	17	22	28	36.2	43	54	70	82	106
$\varnothing B$	12	15	19	24	30	38.2	45	56	72	84	108
α°	0	5	3	4	4	2	5	4	4	5	3

Socket Welding ends size (in mm) :

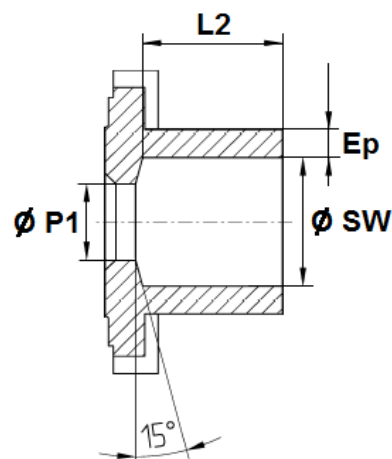

DN	8	10	15	20	25	32	40	50	65	80	100
$\varnothing SW$	13.8	17.7	21.8	27.4	34.2	42.8	48.9	61	76.6	89.6	115.5
$\varnothing P1$	10	10	15	19	25	30	38	51	64	76	101
L2	10	16.5	21	21	21	26	26.6	27.3	42.5	46	51
Ep	2.1	2.15	2.1	2.3	1.8	2.1	2.55	2.5	2.7	2.95	3.4

3 PIECES BALL VALVE FIRE SAFE ADLER TYPE FP3

DEADMAN SIZE (in mm) :

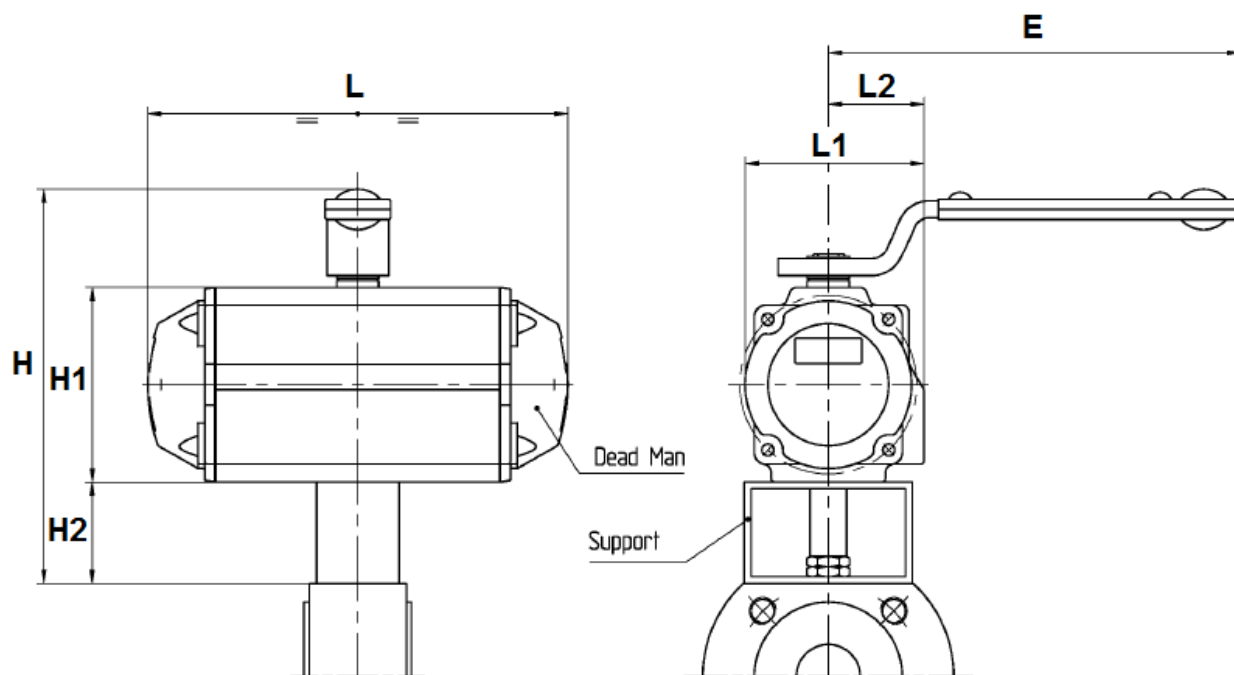

DN	15	20	25	32	40	50
Ref.	9830160	9830161	9830162	9830163	9830164	9830165
L	142	142	161	161	214	252
L1	70.5	70.5	83.5	83.5	94	105
L2	41.5	41.5	47.5	47.5	51	55.5
E	185	185	185	185	280	370
H	157	157	169	169	215	233
H1	69	69	85	85	102	115
H2	40	40	40	40	60	60

3 PIECES BALL VALVE FIRE SAFE ADLER TYPE FP3

GEARBOX SIZE (in mm) :

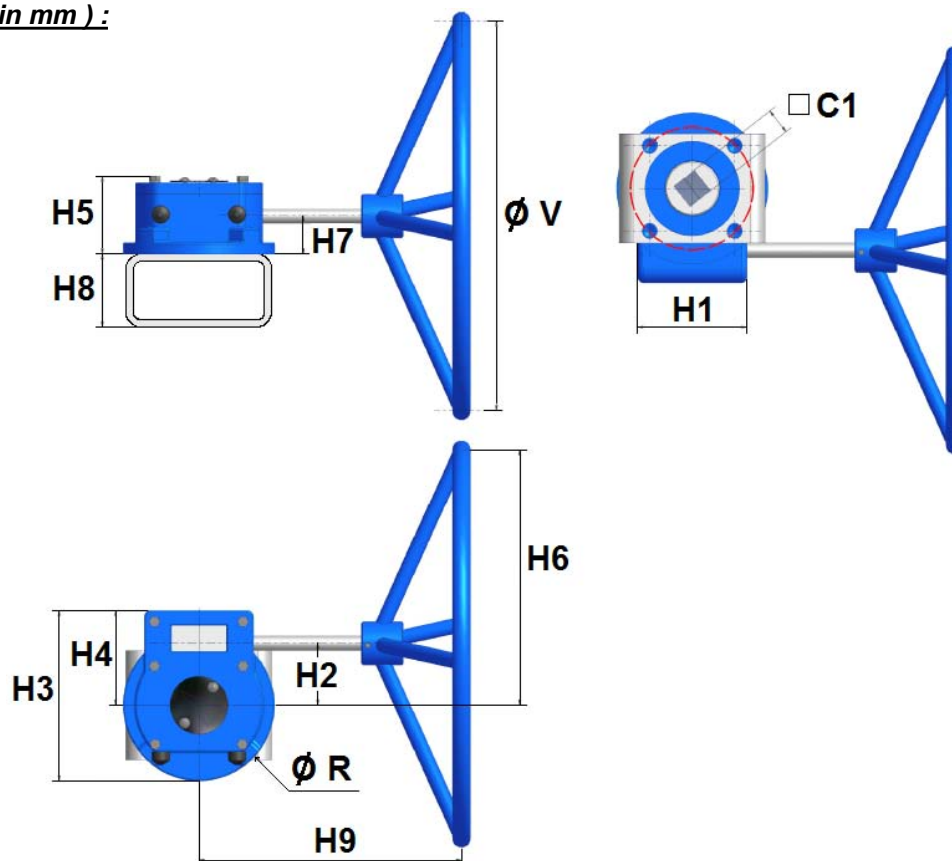

DN	15-50	65-80	100
C1	22	22	22
H1	57	57	100
H2	46	46	55
H3	98	98	143
H4	50.5	50.5	79.5
H5	56	56	73
H6	106	146	205
H7	34	34	35
H8	60	60	80
H9	117	131	250
Ø R	98	98	143
Ø V	120	200	300
Weight (Kg)	2.2	2.3	4.5
Ref.	9830260	9830261	9830262

3 PIECES BALL VALVE FIRE SAFE ADLER TYPE FP3
GEARBOX SPECIFICATIONS :

DN	15-50	65-80	100-150
Ref.	9830260	9830261	9830262
Ratio factor	40 :1	40 :1	37 :1
Input torque (Nm)	35	34	43
Output torque (Nm)	100	150	500

TORQUE VALUES (in Nm without safety coefficient) :

DN	8	10	15	20	25	32	40	50	65	80	100
Torque (Nm) PN100	6	6	-	-	-	-	-	-	-	-	-
Torque (Nm) PN64	-	-	7	13.4	-	-	-	-	-	-	-
Torque (Nm) PN40	-	-	-	-	14.5	18	33	44	-	-	-
Torque (Nm) PN25	-	-	-	-	-	-	-	-	69	84	-
Torque (Nm) PN20	-	-	-	-	-	-	-	-	-	-	144

We recommend a safety coefficient of 2 to choose the actuator

3 PIECES BALL VALVE FIRE SAFE ADLER TYPE FP3**STANDARDS :**

Fabrication according to ISO 9001:2008

DIRECTIVE 97/23/CE : CE N° 0038
Risk category III module H

Designing according to BS EN 12516-2

Construction according to ISO 14313

Materials according to NACE MR 01-75

Pressure tests according to EN 12266-1, range A

Marking according to EN 19

Fire safe according to ISO 10497 up to DN80

Fugitive emissions according to ISO 15848-1 : 2003 Range A

SIL3 according to IEC/EN 61508 (on request)

Threaded BSP cylindrical ends according to ISO 7-1 Rp

Threaded NPT ends according to ANSI B1.20.1 (on request)

Butt Welding ends according to UNI EN 12627 (EX DIN 3239)

ISO 5211 mounting pad

Length according to DIN 3202 M3

ATEX Group II Category 2 GDc TX Zone 1 & 21 Zone 2 & (optional marking)

On request ATEX Group II Category 1G/Dc TX Zone 0 & 20

ADVICE : Our opinion and our advice are not guaranteed and SFERACO shall not be liable for the consequences of damages.
The customer must check the right choice of the products with the real service conditions.

3 PIECES BALL VALVE FIRE SAFE ADLER TYPE FP3

INSTALLATION AND MAINTENANCE

BEFORE INSTALLATION :

Pipe-line must be cleaned and free from residual of weldings, rubbish, shaving and every kind of extraneous materials.
Pipe-line must be perfectly aligned and their support properly dimensioned so that there's no external constraint.

Check to use a produce compatible to the services conditions for the sealing of the threaded types.
To tighten the ends, use the appropriate tool.
Use the right bolt tightening so that the ends won't be damaged.

The welding of the ends for the SW and the BW types, must be done with the central part removed.
A gauge can be used to have the good length and alignment between the ends.

INSTALLATION OF THE CENTRAL PART

During the installation of the central part, tighten bolts according to the table below. Tighten bolts in cross.

CLEANING AND TESTS

Keep closed the valves during the cleaning operation so that there's no impurities between the ball and the body.

Tests under pressure must be done with a cleaned pipe-line.

Open partially the valve for tests. Pressure test do not exceed the valve specifications according to EN 12266-1.

MAINTENANCE

It's recommended to operate the valve twice (open and close) 1 to 2 times per year.

When intervention on the valve, be sure there's no pressure in the pipe-line, there's no fluid in it, and that it is isolated.
The temperature must be low enough to operate without risks.
If there's a corrosive fluid, inert installation before intervention.

When the valve is under pressure :
If there's a leakage between the body and the ends, tighten bolts according to the above table

If there's a leakage at the packing, tighten it slightly so that the leakage disappears.

MAINTENANCE OPERATION IN WORKSHOP

REPLACEMENT OF SEAT GASKETS AND PACKING.

The central part must be removed.

Turn the ball at 45° and removed the seat gaskets.

Operate the valve in closed position to remove the ball. Verify the surface of the ball has no impacts and no scores.

If there are important scores or impacts, replace the ball.

Clean inside the body valve and remove the impurities.

To replace the packing, remove the handle, unscrew the gland nut, extract the stem by the inside of the valve.

Clean the packing seat.

Reassemble thrust washer on stem, introduce stem by the inside of the valve, reassemble packing with packing nut, reassemble hand washer, hand nut and the handle.

Turn stem in closed position and insert the ball.

Then turn the ball in opened position and reassemble the seat.

Place the valve on the installation, tighten bolts according to the above table.

Then proceed to the tests in the same way that the first installation.