

3 PIECES BALL VALVE FLANGED ISO PN40

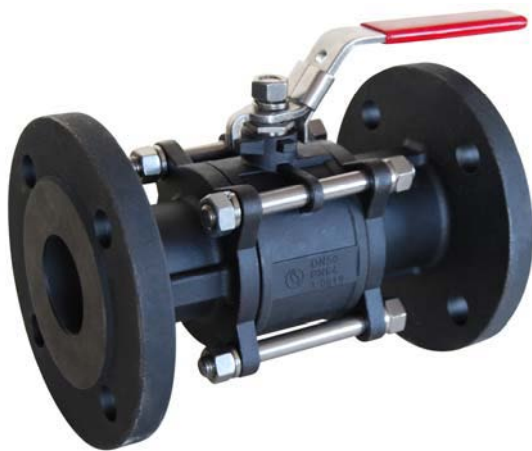

- Size :** DN 15 to 100 mm
Ends : Flanges R.F. ISO PN40
Min Temperature : - 20°C
Max Temperature : + 180°C
Max Pressure : 40 Bars
Specifications : 3 pieces type
PTFE filled with 15% glass fiber seat
Anti blow-out stem
Full bore
Materials : Carbon steel or Stainless steel

3 PIECES BALL VALVE FLANGED ISO PN40

SPECIFICATIONS :

Full bore
Anti blow-out stem
PTFE packing
PTFE filled with 15% glass fiber seat
Locking device
3 pieces type
ISO PN40 R.F. flanges

USE :

Chemical and pharmaceutical industries, petrochemical industries, hydraulic installation, compressed air
Min and max Temperature Ts : -20°C to + 180°C
Max Pressure Ps : 40 bars (see graph)

PRESSURE / TEMPERATURE GRAPH CARBON STEEL TYPES REF.730 (STEAM EXCLUDED) :

(Bar)

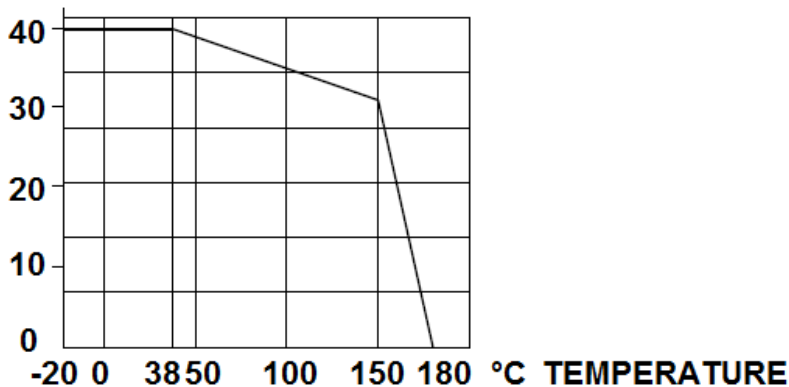

PRESSURE / TEMPERATURE GRAPH STAINLESS STEEL TYPES REF.731 (STEAM EXCLUDED) :

(Bar)

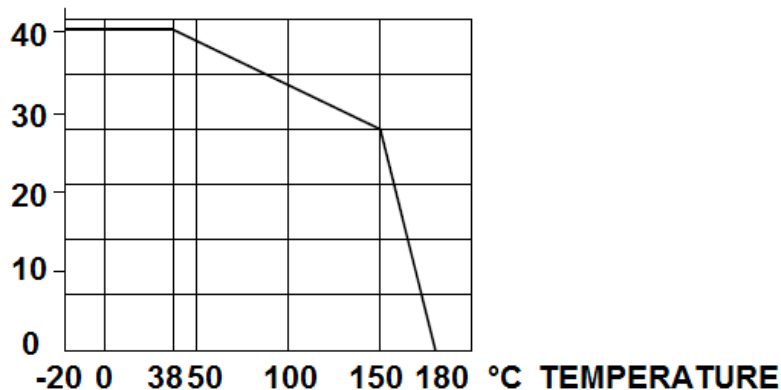

3 PIECES BALL VALVE FLANGED ISO PN40

RANGE :



3 pieces carbon steel ball valve with flanges **Ref. 730** from DN 15 to DN 100



3 pieces stainless steel ball valve with flanges **Ref. 731** from DN 15 to DN 100



SS304 stem extension **Ref.9810601-9810604** from DN15 to DN50



Blue handle cover **Ref. 9830444-9830448** from DN15 to DN100

ENDS :

Flanges R.F. ISO PN40

3 PIECES BALL VALVE FLANGED ISO PN40

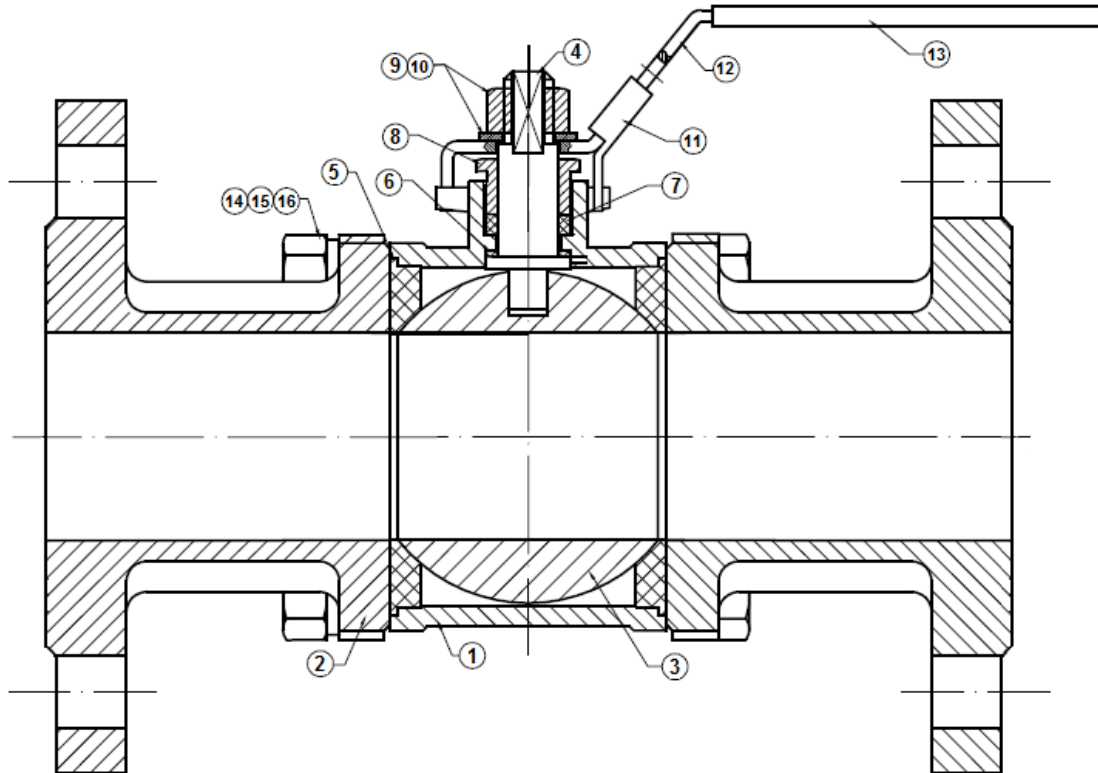
MATERIALS :

Item	Designation	Materials 730	Materials 731
1	Body	ASTM A216 WCB	ASTM A351 CF8M
2	Ends	ASTM A216 WCB	ASTM A351 CF8M
3	Ball	ASTM A351 CF8	ASTM A351 CF8M
4	Stem	SS 316	
5*	Seat	PTFE filled with 15% glass fiber	
6*	Ring	PTFE	
7*	Packing	PTFE	
8	Packing gland	SS 304	
9	Handle nut	SS 304	
10	Handle washer	SS 304	
11	Locking device	SS 304	
12	Handle	SS 304	
13	Handle cover	PVC	
14	Bolt	SS 304	
15	Nut	SS 304	
16	Washer	SS 304	

(* : Included in gaskets kit)

3 PIECES BALL VALVE FLANGED ISO PN40

SIZE (in mm) :

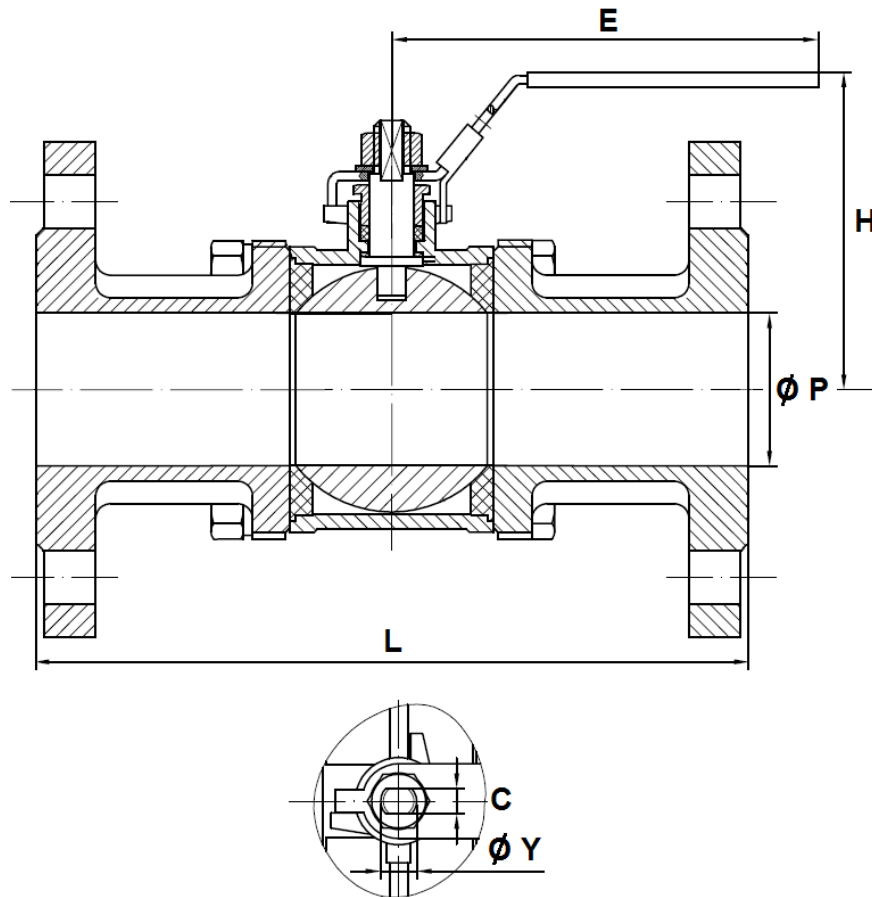

Ref.	DN	15	20	25	32	40	50	65	80	100
730 / 731	Ø P	15	20	25	32	38	50	65	80	100
	L	130	150	160	180	200	230	290	310	350
	E	129	129	143	143	170	170	254	254	335
	H	83	88	89	98	109	120	152	164	170
	C	5	5	6.5	6.5	8.5	8.5	9.8	9.8	16
	Ø Y	M8	M8	M10	M10	M12	M12	M14	M14	M20
730	Weight (Kg)	1.99	2.76	3.57	5.24	6.60	9.69	14.90	20.40	34.20
731	Weight (Kg)	2	2.76	3.58	5.23	6.55	9.62	15.40	20.35	34.20

3 PIECES BALL VALVE FLANGED ISO PN40

FLANGES SIZE (in mm) :

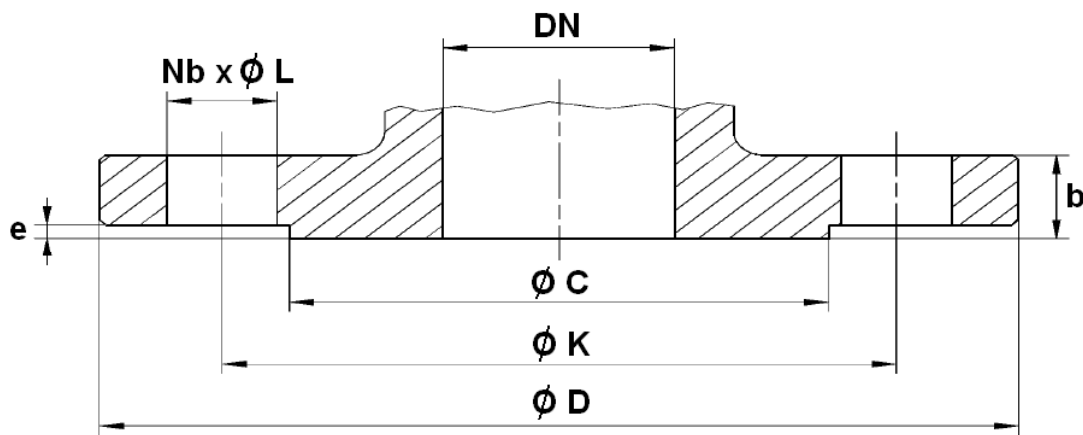

DN	15	20	25	32	40	50	65	80	100
Ø C	45	58	68	78	88	102	122	138	162
Ø D	95	105	115	140	150	165	185	200	235
Ø K	65	75	85	100	110	125	145	160	190
Nb x Ø L	4 x 14	4 x 14	4 x 14	4 x 18	4 x 18	4 x 18	8 x 18	8 x 18	8 x 22
b	16	18	18	18	18	20	22	24	24
e	2	2	2	2	3	3	3	3	3

3 PIECES BALL VALVE FLANGED ISO PN40

STEM EXTENSION SIZE (in mm) :

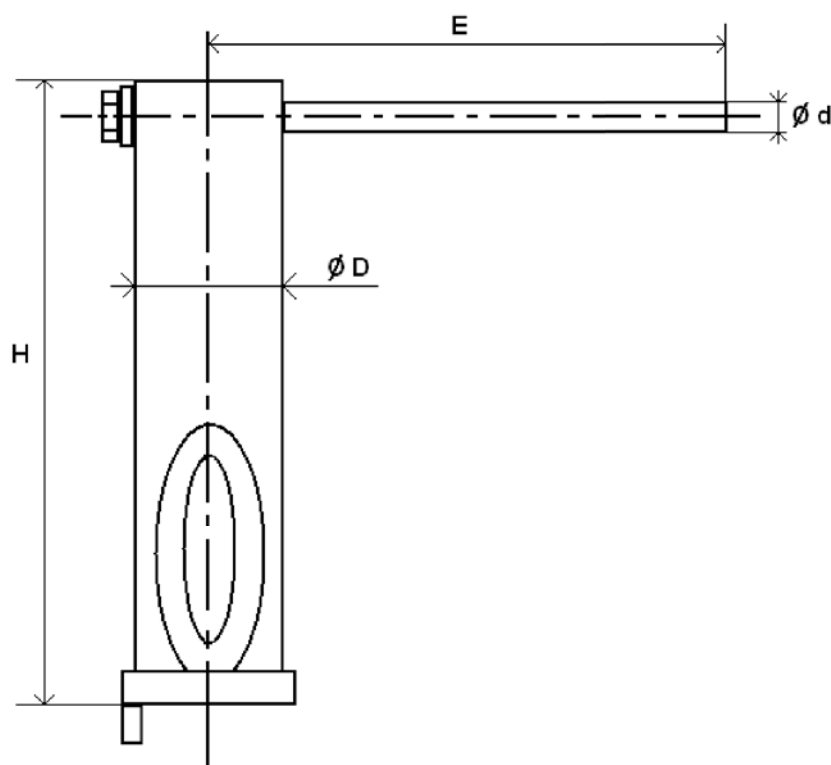

DN	15	20	25	32	40	50
H	125.5	125.5	125.5	125.5	127.5	127.5
E	125	125	158	158	190	190
Ø D	28	28	32	32	36	36
Ø d	12	12	14	14	14	14
Weight (Kg)	0.3	0.3	0.4	0.4	0.6	0.6
Ref.	9810602	9810602	9810603	9810603	9810604	9810604

3 PIECES BALL VALVE FLANGED ISO PN40

FLOW COEFFICIENT Kvs (in m³ / h) :

DN	15	20	25	32	40	50	65	80	100
Kvs (m ³ / h)	28.46	50.70	79.20	128	183	316.6	535.60	811	1267.70

TORQUE VALUES (in Nm without safety coefficient) :

DN	15	20	25	32	40	50	65	80	100
Torque (Nm)	5	8	12.5	17	21	30	45	70	100

BOLT TIGHTENING TABLE (In Nm) :

DN	15	20	25	32	40	50	65	80	100
Torque (Nm)	8	8	10	13	20	20	35	45	65

STANDARDS :

Fabrication according to ISO 9001 : 2008

DIRECTIVE 97/23/CE : CE N° 0035
 Risk category III Module H

Tests according to API 598-04

R.F. flanges according to EN 1092-1 PN40

Length according to EN 558 series 28 (NF 29355 DIN 3202 F1)

ADVICE : Our opinion and our advice are not guaranteed and SFERACO shall not be liable for the consequences of damages.
 The customer must check the right choice of the products with the real service conditions.

3 PIECES BALL VALVE FLANGED ISO PN40

INSTALLATION AND MAINTENANCE

BEFORE INSTALLATION :

Pipe-line must be cleaned and free from residual of weldings, rubbish, shaving and every kind of extraneous materials.
 Pipe-line must be perfectly aligned and their support properly dimensioned so that there's no external constraint.

To tighten the ends, use the appropriate tool.
 Use the right bolt tightening so that the ends won't be damaged.

INSTALLATION OF THE CENTRAL PART

During the installation of the central part, tighten bolts according to the table below. Tighten bolts in cross.

BOLT TIGHTENING TABLE (in Nm) :

DN	15	20	25	32	40	50	65	80	100
Couple (Nm)	8	8	10	13	20	20	35	45	65

CLEANING AND TESTS

Keep closed the valves during the cleaning operation so that there's no impurities between the ball and the body.

Tests under pressure must be done with a cleaned pipe-line.

Open partially the valve for tests. Pressure test do not exceed the valve specifications according to API 598.

MAINTENANCE

It's recommended to operate the valve (open and close) 1 to 2 times per year.

When intervention on the valve, be sure there's no pressure in the pipe-line, there's no fluid in it, and that it is isolated.
 The temperature must be low enough to operate without risks.
 If there's a corrosive fluid, inert installation before intervention.

When the valve is under pressure :
 If there's a leakage between the body and the ends, tighten bolts according to the above table

If there's a leakage at the packing, tighten it slightly so that the leakage disappears.

MAINTENANCE OPERATION IN WORKSHOP

REPLACEMENT OF SEAT GASKETS AND PACKING.

The central part must be removed.

Turn the ball at 45° and removed the seat gaskets.

Operate the valve in closed position to removed the ball. Verify the surface of the ball has no impacts and no scores.

If there are important scores or impacts, replace the ball.

Clean inside the body valve and remove the impurities.

To replace the packing, remove the handle, unscrew the gland nut, extract the stem by the inside of the valve.

Clean the packing seat.

Reassemble thrust washer on stem, introduce stem by the inside of the valve, reassemble packing with packing nut, reassemble hand washer, hand nut and the handle.

Turn stem in closed position and insert the ball.

Then turn the ball in opened position and reassemble the seat.

Place the valve on the installation, tighten bolts according to the above table.

Then proceed to the tests in the same way that the first installation.