

2 PIECES STAINLESS STEEL BALL VALVE PN63



Size : DN 1/4" to 4"
Ends : Threaded BSP or NPT
Min Temperature : - 20°C
Max Temperature : + 180°C
Max Pressure : 63 Bars (up to DN 3/4")
Specifications : Anti blow-out stem
Locking device
Full bore

Materials : Stainless steel

2 PIECES STAINLESS STEEL BALL VALVE PN63

SPECIFICATIONS :

Full bore
Anti blow-out stem
PTFE packing
Locking device
Solid ball
2 pieces type

USE :

Chemical and pharmaceutical industries, petrochemical industries, hydraulic installation, compressed air
Min and max Temperature Ts : -20°C to + 180°C
Max Pressure Ps : 63 bars up to DN3/4", 50 bars from DN 1" to 1"1/4, 40 bars from DN 1"1/2 to 2" , 25 bars from DN 2"1/2 to 3" , 16 bars for DN4" (see graph)

PRESSURE / TEMPERATURE GRAPH (STEAM EXCLUDED) :

PRESSURE

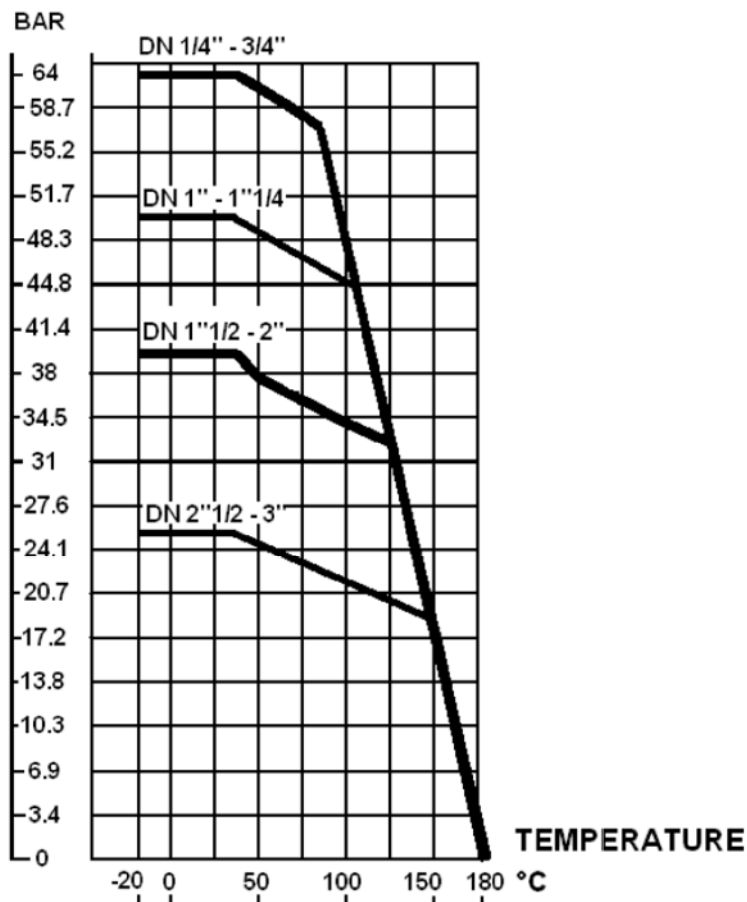

2 PIECES STAINLESS STEEL BALL VALVE PN63

RANGE :



? Stainless steel body NPT threaded with red handle **Ref. 704** DN 1/4" to DN 2"



? Stainless steel body BSP threaded with red handle **Ref. 706** DN 1/4" to DN 4"



? Stainless steel body BSP threaded with red SS304 butterfly handle **Ref. 7061** DN 1/4" to DN 1"



? Blue handle cover **Ref. 9830380 to 9830384** DN 1/4" to DN 3"



? S.S. 304 red butterfly handle **Ref. 9831131 to 9831134** DN 1/4" to DN 1"

2 PIECES STAINLESS STEEL BALL VALVE PN63

MATERIALS :

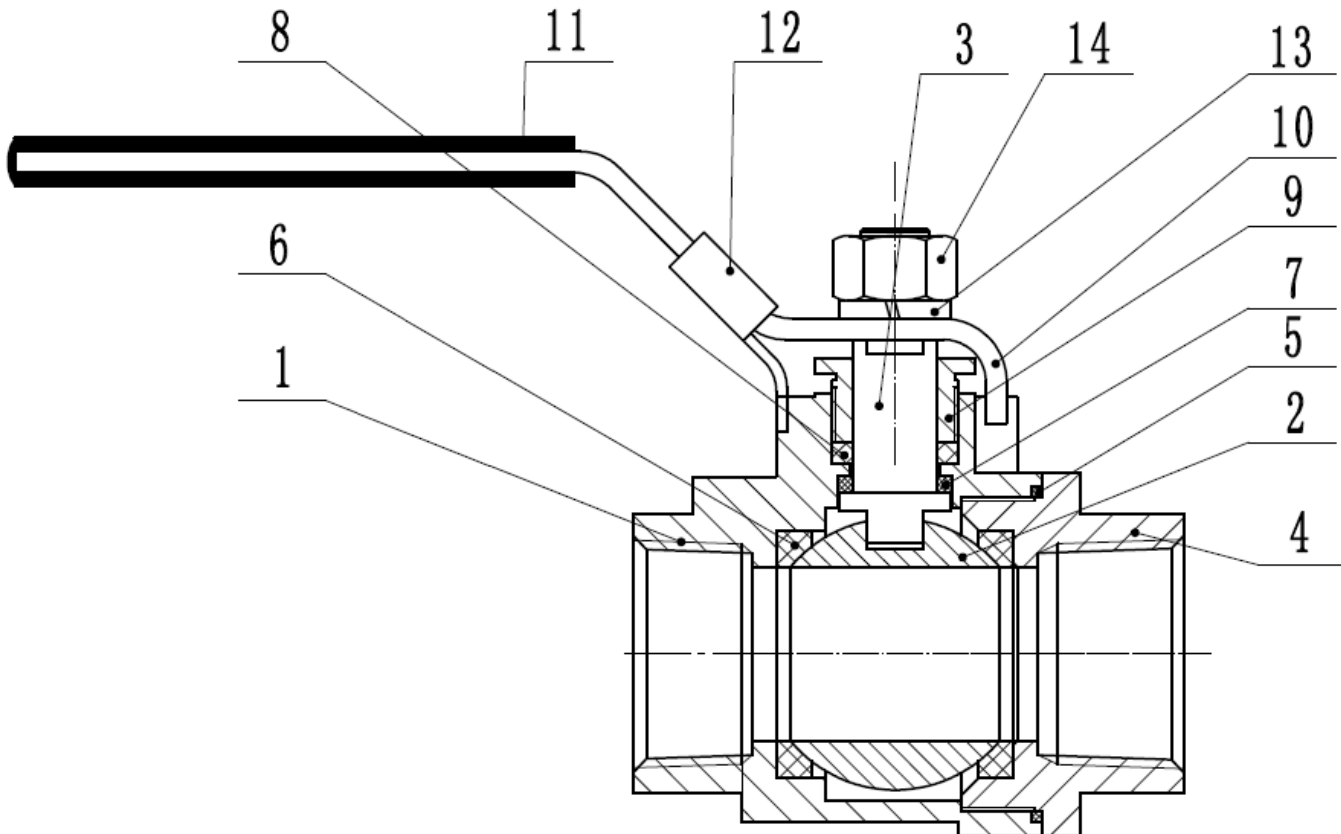

Item	Designation	Materials
1	Body	ASTM A351 CF8M
2	Ball	
3	Stem	AISI 316
4	End	ASTM A351 CF8M
5	Body gasket	PTFE
6	Seat	
7	Gasket	
8	Packing	
9	Packing nut	AISI 304
10	Handle	
11	Handle cover	Plastic
12	Locking device	AIS 304
13	Washer	
14	Nut	

2 PIECES STAINLESS STEEL BALL VALVE PN63

SIZE (in mm) :

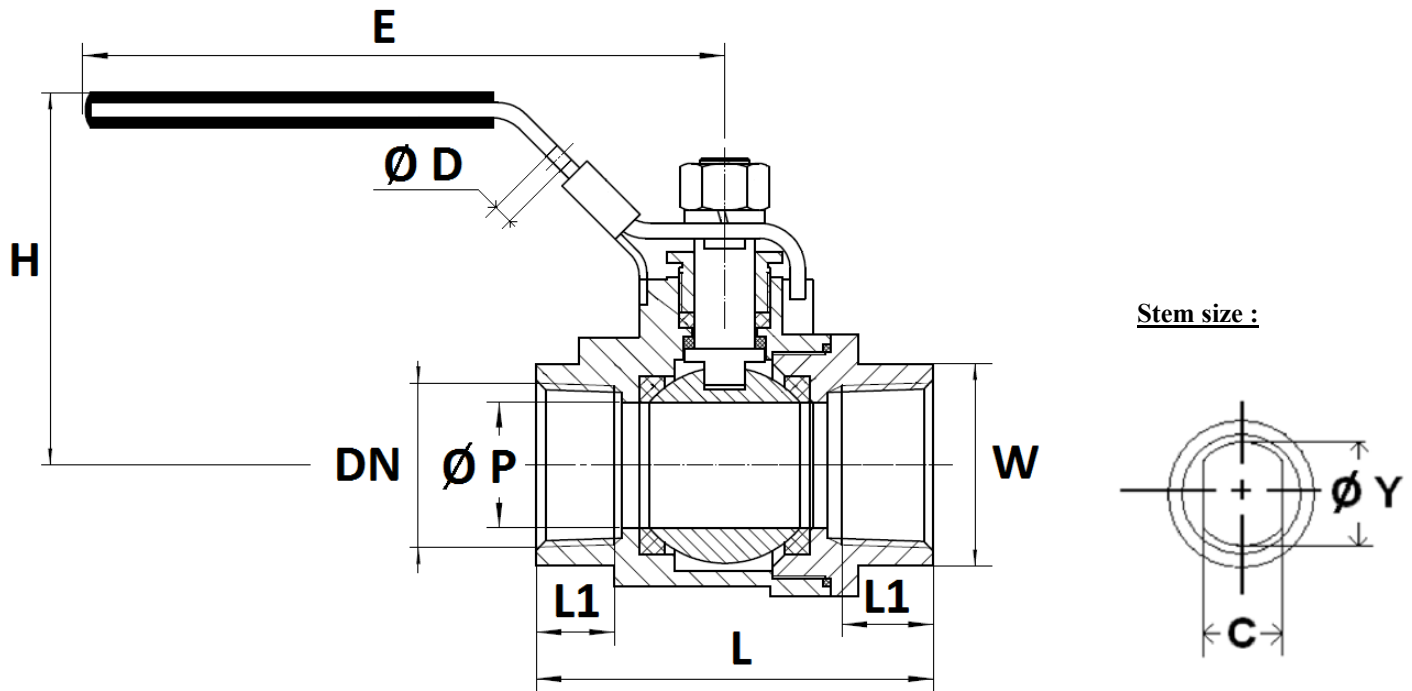

Ref.	DN	1/4"	3/8"	1/2"	3/4"	1"	1"1/4	1"1/2	2"	2"1/2	3"	4"
704 / 706	Ø P	9.2	12.5	15	20	25	32	38	50	65	80	100
	L	48.6	52	59	65	76	90	101.5	120.5	157	176	212
	Ø D	8	8	8	8	8	8	8	8	8	8	8
	E	83	83	103	103	151	151	194	194	285	285	285
	H	49	53	60	62	77	81	91	103	117	127	146
	L1	10	12	13.5	14.5	16.5	19	19	22	28	32	32
	W on flat	19	22	26	32	38	50	54	68	85	98	125
	C	4	5	6.5	6.5	8	8	8.5	8.5	12	12	12
	Ø Y	6	7	7.5	7.5	9	9	11	11	15.5	15.5	15.5
Weight (Kg)	0.195	0.228	0.284	0.370	0.610	0.996	1.590	2.562	5.33	7.737	13	

2 PIECES STAINLESS STEEL BALL VALVE PN63

BUTTERFLY HANDLE SIZE (in mm) :

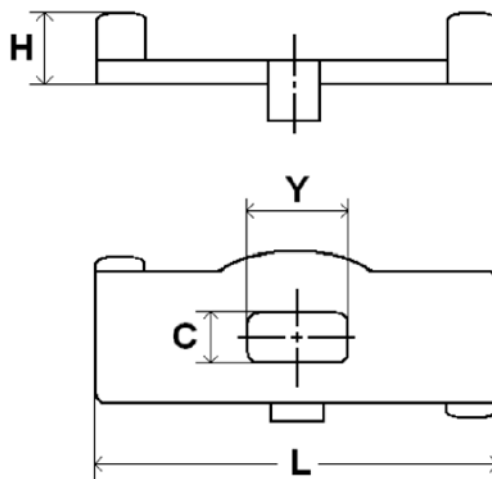

? Ref. 983113 :

DN	1/4"	3/8"	1/2"	3/4"	1"
L	55	55	60	60	70
H	20	20	22	22	28
C	4	5	6.5	6.5	8
Y	7	8	9.5	9.5	11.5

TORQUE VALUES (in Nm without safety coefficient) :

DN	1/4"	3/8"	1/2"	3/4"	1"	1"1/4"	1"1/2"	2"	2"1/2"	3"	4"
Torque (Nm)	2.7	2.7	3	4	5	6	8	10	40	60	100

2 PIECES STAINLESS STEEL BALL VALVE PN63

STANDARDS :

Fabrication according to ISO 9001 : 2008

DIRECTIVE 97/23/CE : CE N° 0035
Risk category III Module H

Pressure Tests according to ISO 5208, range A

Threaded ends BSP cylindrical according to ISO 228-1

Threaded ends NPT according to ANSI B1.20

ADVICE : Our opinion and our advice are not guaranteed and SFERACO shall not be liable for the consequences of damages. The customer must check the right choice of the products with the real service conditions.

INSTALLATION AND MAINTENANCE

BEFORE INSTALLATION :

Pipe-line must be cleaned and free from residual of weldings, rubbish, shaving and every kind of extraneous materials. Pipe-line must be perfectly aligned and their support properly dimensioned so that there's no external constraint.

Please use the right product according to the services conditions to seal the valve.
Use the right bolt tightening so that the ends won't be damaged.

CLEANING AND TESTS

Keep closed the valves during the cleaning operation so that there's no impurities between the ball and the body.

Tests under pressure must be done with a cleaned pipe-line.

Open partially the valve for tests. Pressure test do not exceed the valve specifications according to ISO 5208.

MAINTENANCE

It's recommended to operate the valve twice (open and close) 1 to 2 times per year.

When intervention on the valve, be sure there's no pressure in the pipe-line, there's no fluid in it, and that it is isolated. The temperature must be low enough to operate without risks.
If there's a corrosive fluid, inert installation before intervention.

When the valve is under pressure :

If there's a leakage at the packing, tighten it slightly so that the leakage disappears.