

**DOUBLE ECCENTRIC BUTTERFLY VALVE CLASS 150 PN20**

  
**armat**  
spol. s r.o.  
MADE OF STAINLESS...



**Size :** DN 50 to 600 mm ( NPS 2" to 24" )  
**Ends :** Between Class 150 (PN20) flanges  
**Min Temperature :** - 29°C  
**Max Temperature :** + 210°C  
**Max Pressure :** 20 Bars  
**Specifications :** Double eccentric  
Wafer type  
Fire safe according to ISO 10497 : 2010  
ISO 5211 mounting pad

**Materials :** Carbon steel or stainless steel

**DOUBLE ECCENTRIC BUTTERFLY VALVE CLASS 150 PN20**

**SPECIFICATIONS :**

100% tightness  
 Wafer type  
 Between Class 150 (PN20) flanges  
 Double eccentric  
 Bidirectional with preferential flow direction indicated by the arrow  
 Fire safe according to ISO 10497 : 2010  
 ISO 5211 mounting pad  
 Stainless steel CF8M disc  
 Full crossing stem  
 10 positions ductile iron handle, with locking device up to DN150 ( NPS 6" )  
 Gear box from DN 200 to DN600 ( NPS 8" to 24" )  
 Inorganic zinc rich primer, gray color, 10 µm thickness for carbon steel type (Ref. 1115)  
 Finish painting heat resisting aluminum Silver color RAL 1504, 30 µm thickness for carbon steel type (Ref. 1115)  
 Ductile iron EN GJS-400-15 handle with silver painting RAL 9006 color

**USE :**

Heating, geothermics, industrial cold, shipbuilding, petrochemical  
 Steam : 10 bars maximum  
 Min and max Temperature Ts : - 29°C to + 210°C  
 Max Pressure Ps : 20 bars ( see graph )  
 When using at dead end of pipeline, reverse preferential flow direction

**RANGE :**

Wafer type with carbon steel body , and handle **Ref. 1115** DN 50 to DN 150 ( NPS 2" to 6" )  
 Wafer type with carbon steel body , and gear box **Ref. 1115** DN 200 to DN 600 ( NPS 8" to 24" )  
 Wafer type with stainless steel body , and lever **Ref. 1116** DN 50 to DN 150 ( NPS 2" to 6" )  
 Wafer type with stainless steel body , and gear box **Ref. 1116** DN 200 to DN 600 ( NPS 8" to 24" )  
 Gear box **Ref. 1193** from DN 50 to DN 150 ( NPS 2" to 6" )

**ENDS :**

Between Class 150 (PN20) flanges

**PRESSURE / TEMPERATURE GRAPH :**

**PRESSURE**

**( Bar )**

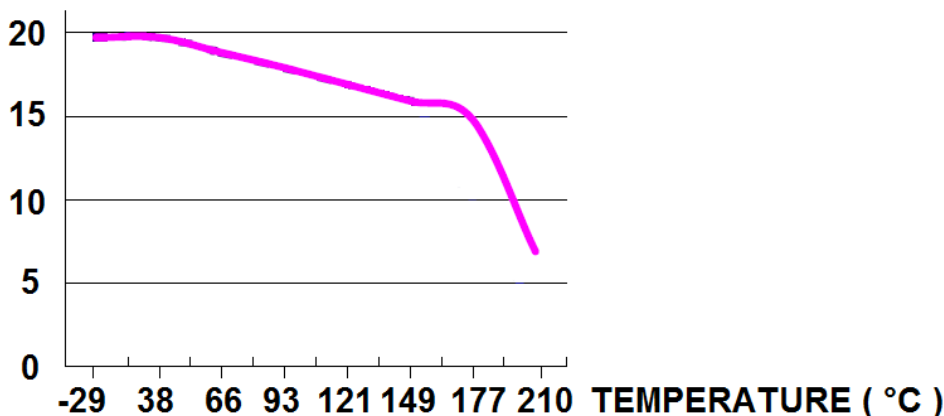

**DOUBLE ECCENTRIC BUTTERFLY VALVE CLASS 150 PN20**

TORQUE VALUE ( in Nm with safety coefficient of 30 % included ) :

DN	50	65	80	100	125	150	200	250	300	350	400	450	500	600
NPS	2"	2"1/2"	3"	4"	5"	6"	8"	10"	12"	14"	16"	18"	20"	24"
Torque ( Nm ) at 0 Bar	30	30	40	60	120	150	180	200	280	470	670	860	1100	1300
Torque ( Nm ) at 5 Bar	30	40	50	70	140	200	240	280	400	740	980	1080	1410	1650
Torque ( Nm ) at 10 Bar	40	50	70	80	160	230	300	350	560	850	1290	1390	1840	2270
Torque ( Nm ) at 15 Bar	40	70	80	100	170	270	360	420	700	1010	1540	1740	2210	2840
Torque ( Nm ) at 20 Bar	50	80	90	130	180	300	430	530	880	1220	1720	2130	2980	3860
Torque ( Nm ) at 25 Bar	50	90	100	150	200	340	490	600	1030	1450	1920	2700	3480	4800

FLOW COEFFICIENT Kv ( m3 / h ) :

DN	50	65	80	100	125	150	200	250	300	350	400	450	500	600	
NPS	2"	2"1/2"	3"	4"	5"	6"	8"	10"	12"	14"	16"	18"	20"	24"	
Opening angle	10°	0.26	0.86	1.73	3.46	6.05	9.5	17.3	25.95	34.6	47.6	64.9	82.2	108.1	173
	20°	1.73	9.5	17.3	27.7	47.6	77.8	129.7	207.5	311.3	389.2	562.2	691.9	864.9	1470
	30°	5.18	23.35	43.2	69.2	121	198.9	337.3	518.9	795.7	977.3	1383.8	1729.8	2335.2	3805
	40°	10.38	34.6	63.1	103.8	173	294	484.3	752.4	1150.3	1418.4	1989.2	2508.1	3373	5448
	50°	17.3	51.9	95.1	155.7	259.5	441.1	735.1	1133	1729.8	2162.2	3027.1	3805.5	5102.8	8216
	60°	27.7	71.8	133.2	216.2	371.9	614	1029.2	1591	2421.7	3027	4237.9	5275.8	7092	11502
	70°	43.24	91.7	173	276.8	475.7	787	1314.6	2041	3113.6	3892	5448.8	6832.6	9081.3	14703
	80°	53.6	115	216.2	346	588.1	986	1643.2	2542.7	3892	4756.9	6789.3	8562.3	11243	18422
	90°	57.08	121	224.9	363.2	622.7	1037.8	1729.7	2681.1	4108.2	5059.5	7178.5	8994.8	11935	19459

**DOUBLE ECCENTRIC BUTTERFLY VALVE CLASS 150 PN20**

MATERIALS VALVES :

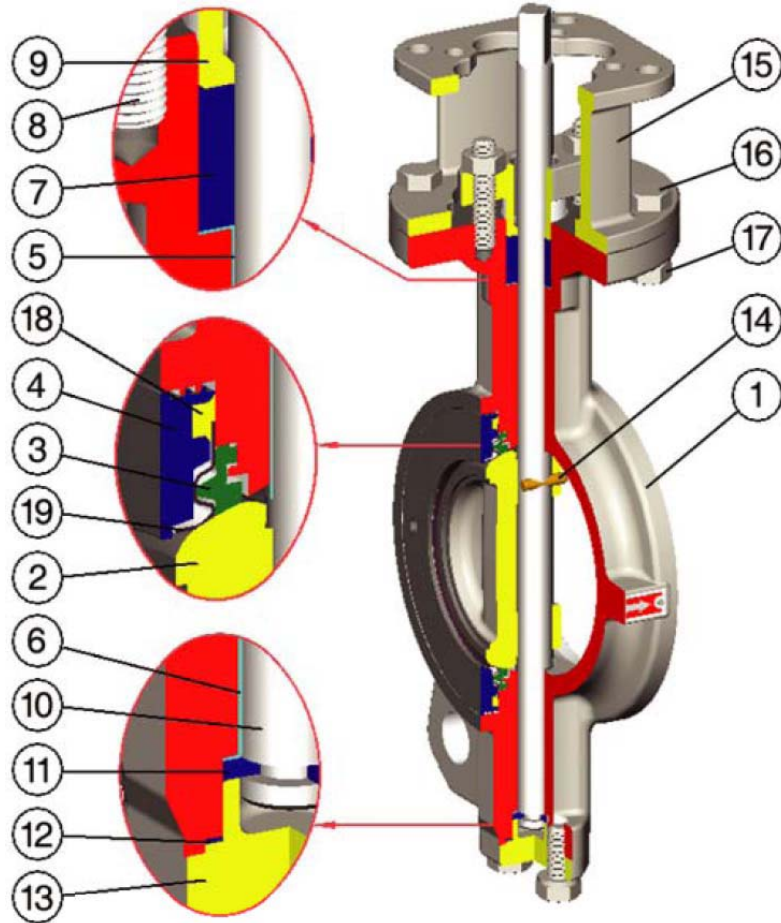

Item	Designation	Materials 1115	Materials 1116
1	Body	ASTM A216 WCB	ASTM A351 CF8M
2	Disc	ASTM A351 CF8M	
3*	Seat	PTFE with 15% graphite	
4	Retainer	ASTM A351 CF8	
5	Bushing	PTFE + SS 316	
6	Bushing	PTFE + SS 316	
7*	Gland packing	Graphite	
8	Stud	ASTM A193 B8	
9	Gland	ASTM A351 CF8	
10	Stem	ASTM A564 630	
11	Thrust ring	ASTM A240 Gr. 316	
12*	Seal	Graphite	
13	Bottom cover	ASTM A216 WCB	ASTM A351 CF8M
14	Pin	ASTM A182 F316	
15	Yoke	ASTM A216 WCB	ASTM A351 CF8
16	Bolt	ASTM A193 B8	
17	Nut	ASTM A194 Gr. 8	
18*	Gasket	Graphite	
19	Metal seat	ASTM A240 Gr. 316	

(\* : included in gaskets kit)

**DOUBLE ECCENTRIC BUTTERFLY VALVE CLASS 150 PN20**

**MATERIALS GEARBOX DN50 – 350 (NPS 2" to 14" ) :**

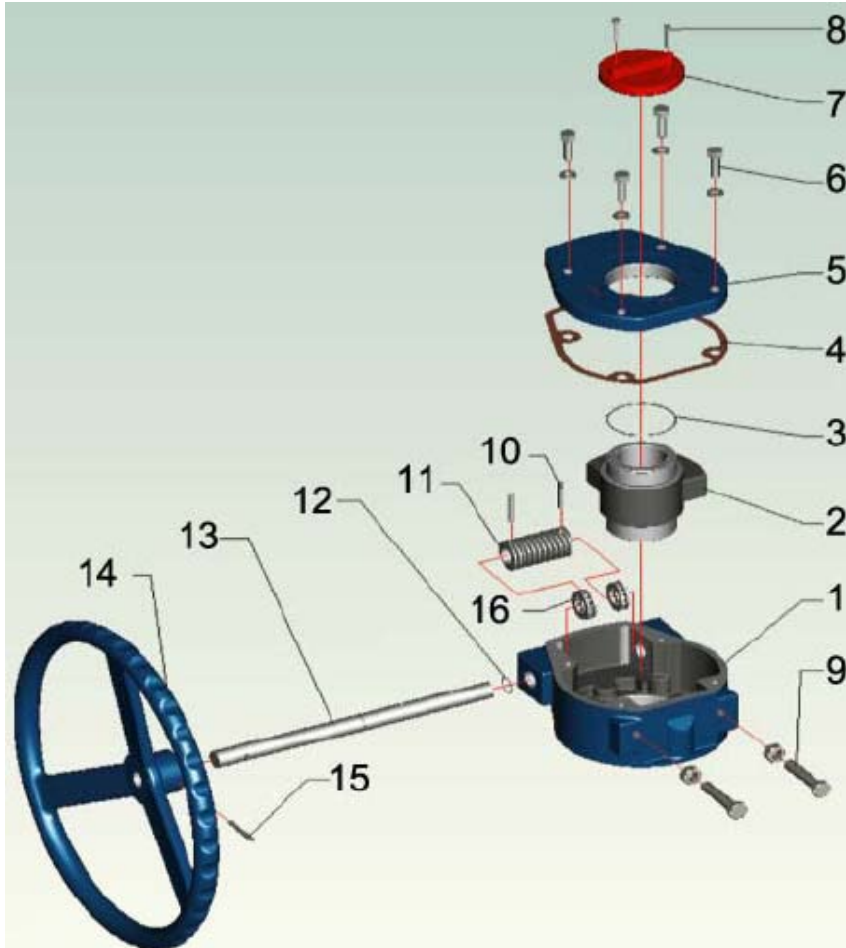

Item	Designation	Materials
1	Body	Cast iron
2	Worm gear	Ductile iron
3	O ring	NBR
4	Gasket	Paper
5	Cover	Cast iron
6	Screw	Steel
7	Indicator	Cast iron
8	Screw	Steel
9	Stop bolt	Steel
10	Pin	Steel
11	Worm	Steel
12	O ring	NBR
13	Worm shaft	Steel
14	Handwheel	Cast iron
15	Pin	Steel
16	Bearing	Steel

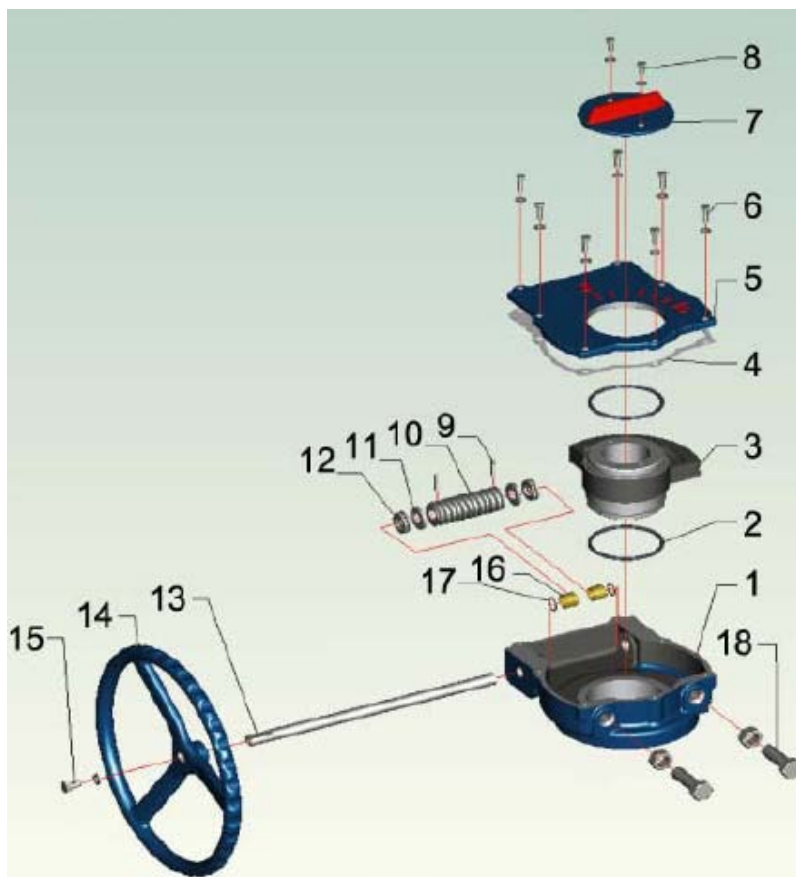
**DOUBLE ECCENTRIC BUTTERFLY VALVE CLASS 150 PN20**
**MATERIALS GEARBOX DN400 – 600 ( NPS 16" to 24" ) :**

Item	Designation	Materials
1	Body	Cast iron
2	O ring	NBR
3	Worm gear	Ductile iron
4	Gasket	Paper
5	Cover	Cast iron
6	Screw	Steel
7	Indicator	Cast iron
8	Screw	Steel
9	Pin	Steel
10	Worm	Steel
11	Ring	Steel
12	Bearing	Steel
13	Worm shaft	Steel
14	Handwheel	Cast iron
15	Screw	Steel
16	Bushing	Copper
17	O ring	NBR
18	Stop bolt	Steel

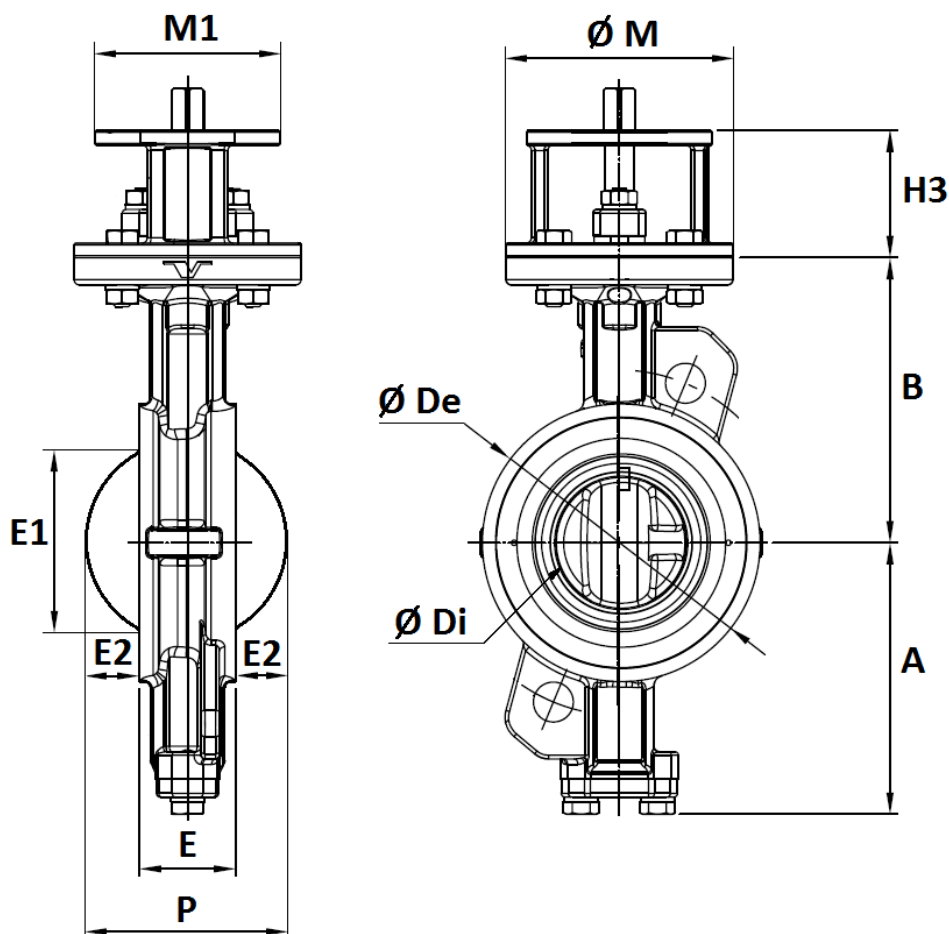
**DOUBLE ECCENTRIC BUTTERFLY VALVE CLASS 150 PN20**
**VALVE SIZE DN50 - 150 ( in mm ) :**

NPS	2"	2"1/2	3"	4"	5"	6"
DN	50	65	80	100	125	150
E	43	46	47	53	57	56
A	99	110	128	150	163	176
B	118	125	140	157	170	185
H3	60	60	70	70	70	70
Ø M	90	90	125	125	125	125
M1	70	70	102	102	102	102
P	47	76	91	103	129	156
E1	49.5	62.3	65.9	93	120	149
E2	2	15	22	25	36	50
Ø De	92	108	126	153	184	212
Ø Di	37	63	78	95	118	143
Min pipe diameter	49	62	78	93	120	149
Weight (in Kg)	3.9	4.5	7	9	12	13.5

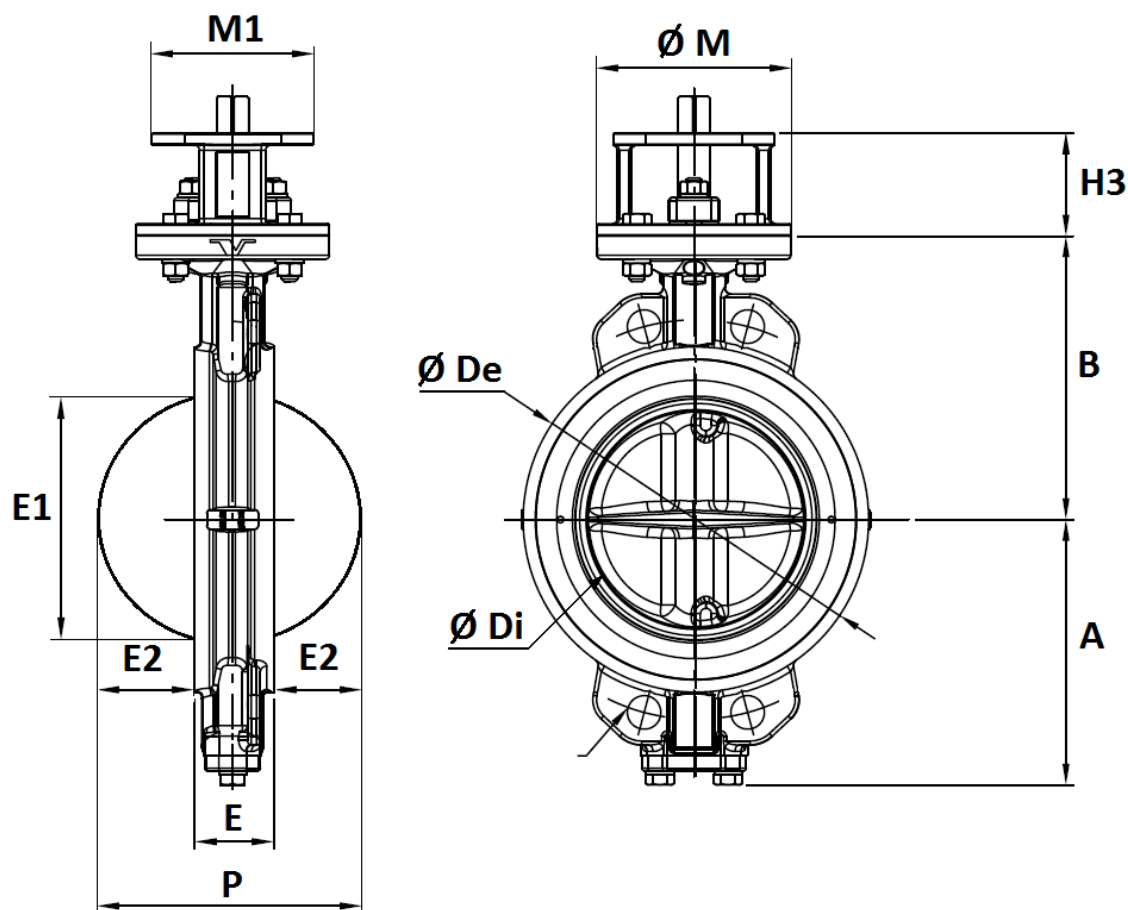
**DOUBLE ECCENTRIC BUTTERFLY VALVE CLASS 150 PN20**
**VALVE SIZE DN200 - 400 ( in mm ) :**

NPS	8"	10"	12"	14"	16"
DN	200	250	300	350	400
E	62	68	78	78	102
A	206	238	269	306	342
B	220	260	290	326	370
H3	80	80	100	100	120
Ø M	150	150	175	175	210
M1	125	125	160	160	195
P	202	248	290	328	382
E1	196	243	289	329	377
E2	70	90	106	125	140
Ø De	268	326	375	416	476
Ø Di	187.6	235.5	282	322	371
Min pipe diameter	196	243	289	329	377
Weight (in Kg)	22	32	48	66	107



**DOUBLE ECCENTRIC BUTTERFLY VALVE CLASS 150 PN20**

VALVE SIZE DN450 - 600 ( in mm ) :

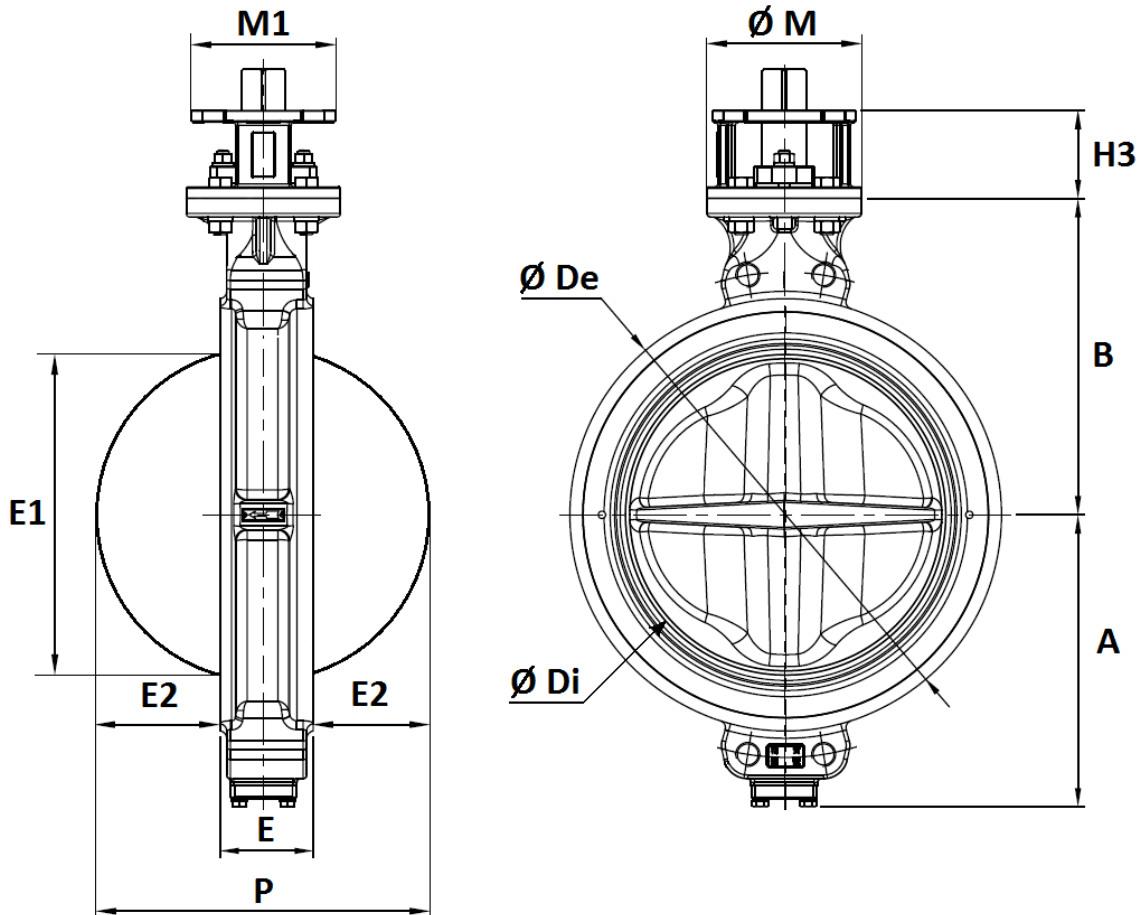

NPS	18"	20"	24"
DN	450	500	600
E	114	127	154
A	370	399	455
B	395	430	490
H3	120	120	150
Ø M	210	210	300
M1	195	195	300
P	428	481	574
E1	423	471	572
E2	157	177	210
Ø De	534	588	692
Ø Di	418	466	570
Min pipe diameter	423	471	572
Weight (in Kg)	130	163	278

**DOUBLE ECCENTRIC BUTTERFLY VALVE CLASS 150 PN20**

*HANDLE SIZE (in ductile iron EN GJS-400-15 with silver painting RAL 9006 color ) :*



<b>DN</b>	<b>50</b>	<b>65</b>	<b>80</b>	<b>100</b>	<b>125</b>	<b>150</b>
<b>NPS</b>	<b>2"</b>	<b>2"1/2</b>	<b>3"</b>	<b>4"</b>	<b>5"</b>	<b>6"</b>
<b>L</b>	<b>200</b>	<b>200</b>	<b>250</b>	<b>250</b>	<b>355</b>	<b>355</b>
<b>Weight (Kg)</b>	<b>0.7</b>	<b>0.7</b>	<b>0.8</b>	<b>0.8</b>	<b>1.6</b>	<b>1.6</b>

**DOUBLE ECCENTRIC BUTTERFLY VALVE CLASS 150 PN20**

GEARBOX SIZE DN 50-350 (NPS 2" to 14") :

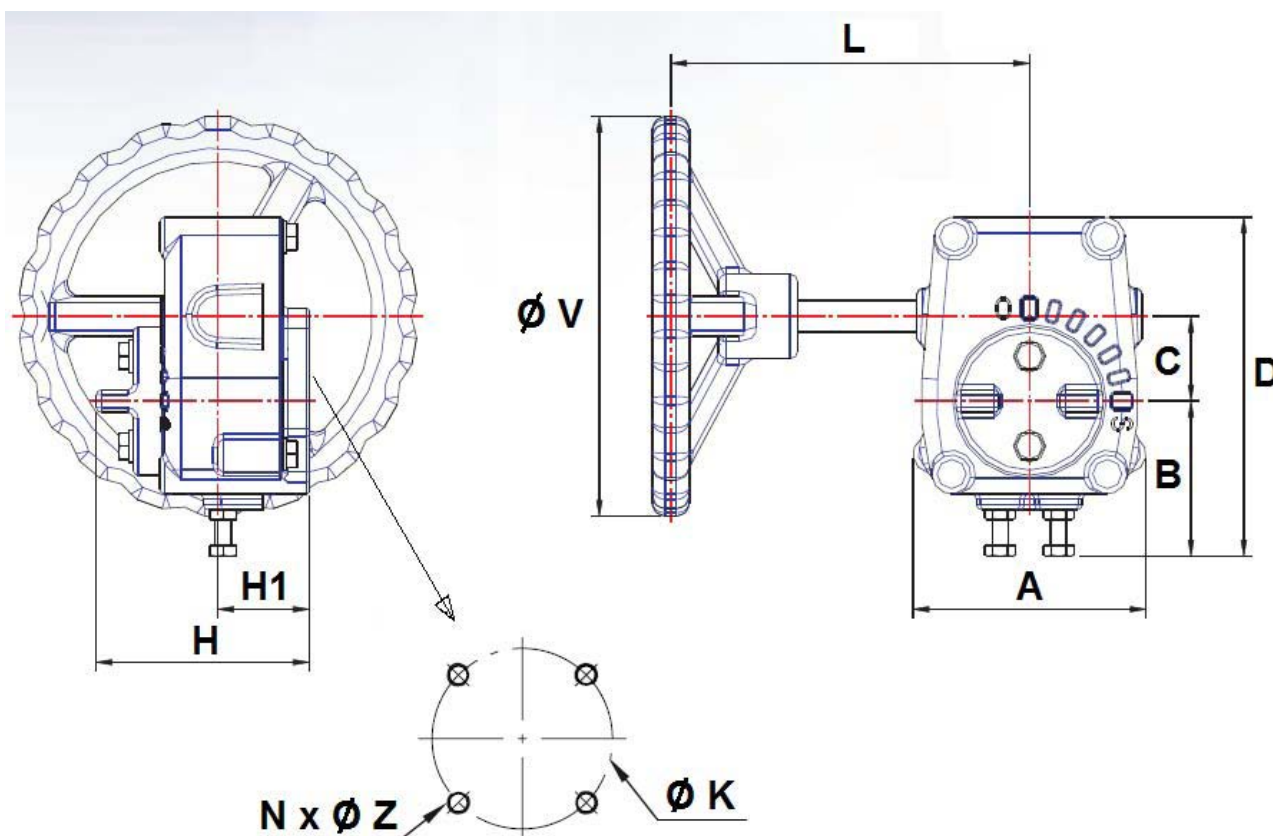

DN	50-80	100-150	200-250	300-350
NPS	2"-3"	4"-6"	8"-10"	12"-14"
L	155	195	258	346
A	87	117	153	181
B	49	81	97	102
C	41	63	61	81
D	130	176	186	223
H	81	91	88	117
H1	37	41.5	41	52
Ø V	150	200	310	400
Ø K	70	102	125	140
ISO	F07	F10	F12	F14
N x Ø Z	4 x M8	4 x M10	4 x M12	4 x M16
Weight (Kg)	3.3	7.5	9	22

**DOUBLE ECCENTRIC BUTTERFLY VALVE CLASS 150 PN20**

GEARBOX SIZE DN 400-600 ( NPS 16" to 24" ):

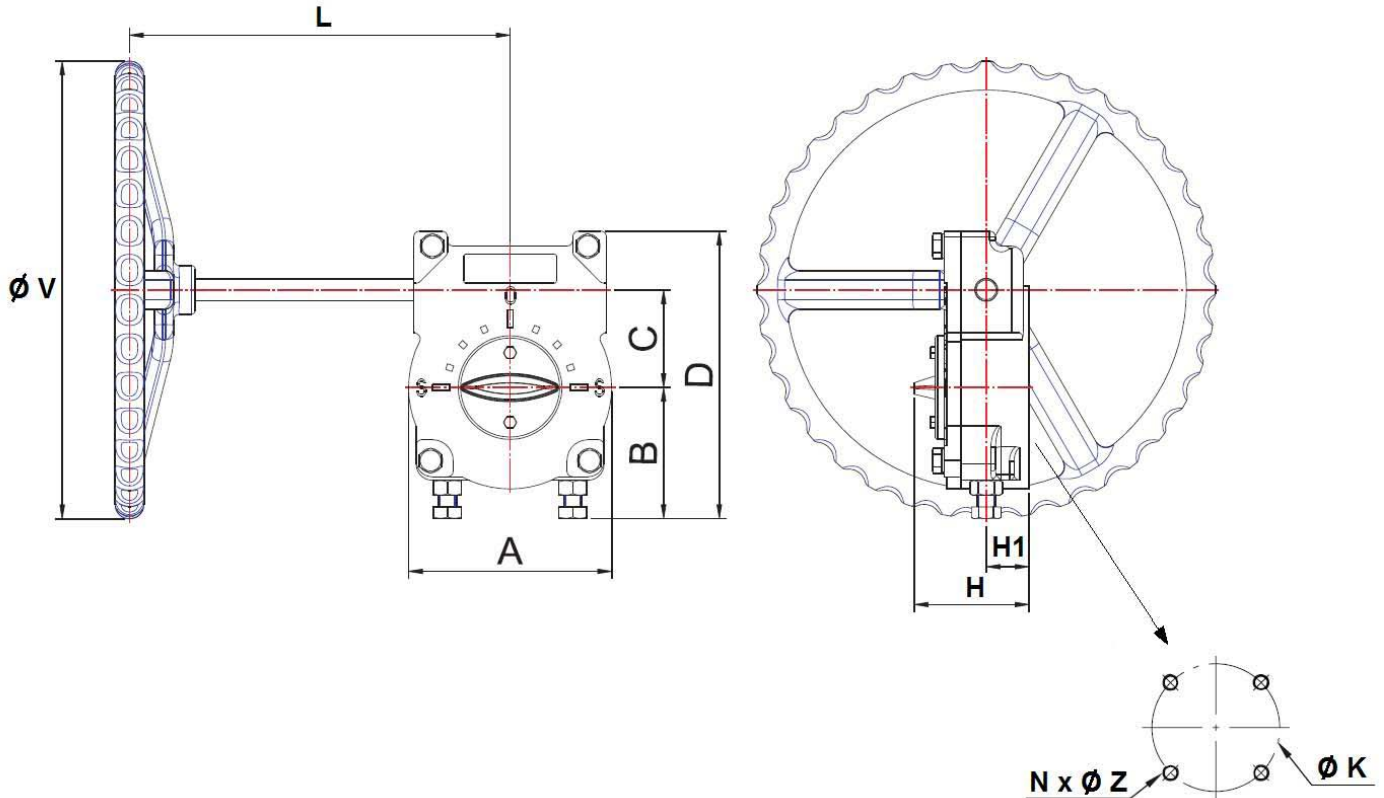

DN	400-500-600
NPS	16"-20"-24"
L	307
A	251
B	113
C	123
D	293
H	127
H1	56
ØV	400
ØK	165
ISO	F16
N x ØZ	4 x M20
Weight (Kg)	35

**DOUBLE ECCENTRIC BUTTERFLY VALVE CLASS 150 PN20**

*ISO MOUNTING PAD AND STEM SIZE ( in mm ) :*

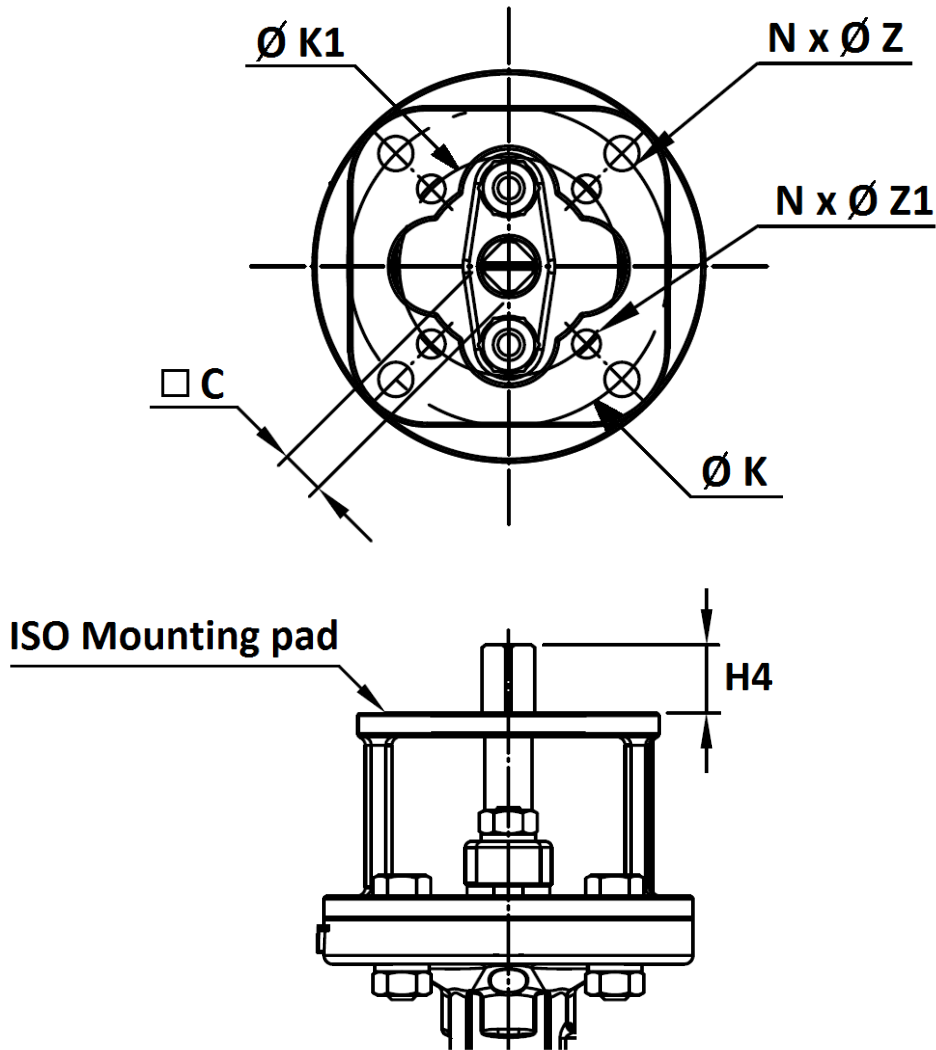

NPS	2"	2"1/2	3"	4"	5"	6"	8"	10"	12"	14"	16"	18"	20"	24"
DN	50	65	80	100	125	150	200	250	300	350	400	450	500	600
C	11	11	14	14	17	17	19	22	27	27	36	36	46	46
H4	18	18	23	23	23	23	28	28	37	37	47	47	56	56
$\varnothing K$	70	70	102	102	102	102	125	125	140	140	165	165	165	254
ISO	F07	F07	F10	F10	F10	F10	F12	F12	F14	F14	F16	F16	F16	F25
$N \times \varnothing Z$	4 x 8	4 x 8	4 x 10	4 x 10	4 x 10	4 x 10	4 x 12	4 x 12	4 x 16	4 x 16	4 x 22	4 x 22	4 x 22	8 x 17
$\varnothing K1$	50	50	70	70	70	70	102	102	125	125	140	140	140	-
ISO1	F05	F05	F07	F07	F07	F07	F10	F10	F12	F12	F14	F14	F14	-
$N \times \varnothing Z1$	4 x 6	4 x 6	4 x 8	4 x 8	4 x 8	4 x 8	4 x 10	4 x 10	4 x 12	4 x 12	4 x 16	4 x 16	4 x 16	-

**DOUBLE ECCENTRIC BUTTERFLY VALVE CLASS 150 PN20**

*BETWEEN FLANGES CLASS 150 PN20 SIZE ( in mm ) :*

**DN 50 – 150**

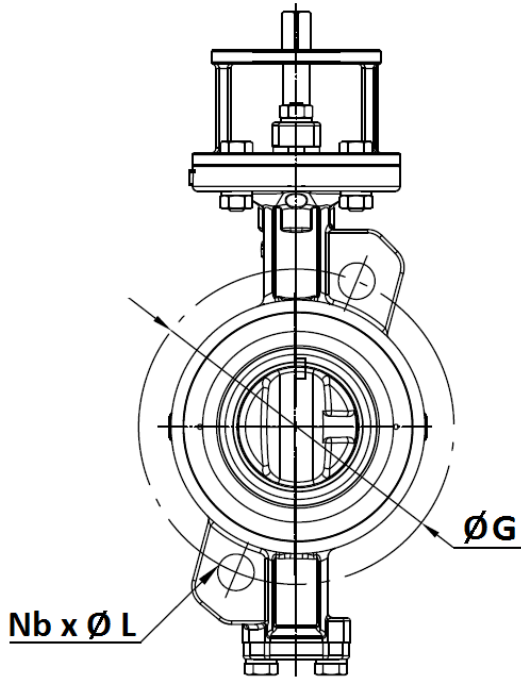

**DN 200 - 400**

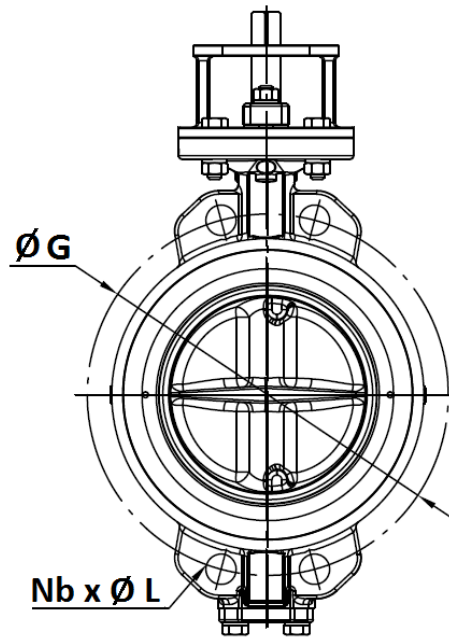

**DN 450 - 600**

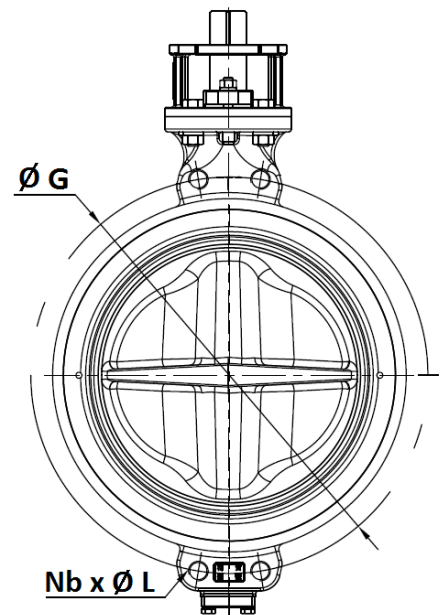

NPS	2"	2 1/2"	3"	4"	5"	6"	8"	10"	12"	14"	16"	18"	20"	24"
DN	50	65	80	100	125	150	200	250	300	350	400	450	500	600
Ø G	120.6	139.7	152.4	190.5	215.9	241.3	298.4	362	431.8	476.2	539.8	577.8	635	749.3
Nb x Ø L	2 x 19	2 x 19	2 x 19	2 x 19	2 x 22.2	2 x 22.2	4 x 22.2	4 x 25.4	4 x 25.4	4 x 28.6	4 x 28.6	4x M30	4x M30	4x M33
Ref.	1115050 - 1116050	1115065 - 1116065	1115080 - 1116080	1115100 - 1116100	1115125 - 1116125	1115150 - 1116150	1115200 - 1116200	1115250 - 1116250	1115300 - 1116300	1115350 - 1116350	1115400 - 1116400	1115450 - 1116450	1115500 - 1116500	1115600 - 1116600

**DOUBLE ECCENTRIC BUTTERFLY VALVE CLASS 150 PN20**

**BOLTING SIZE ( in mm, not included with valves ) :**

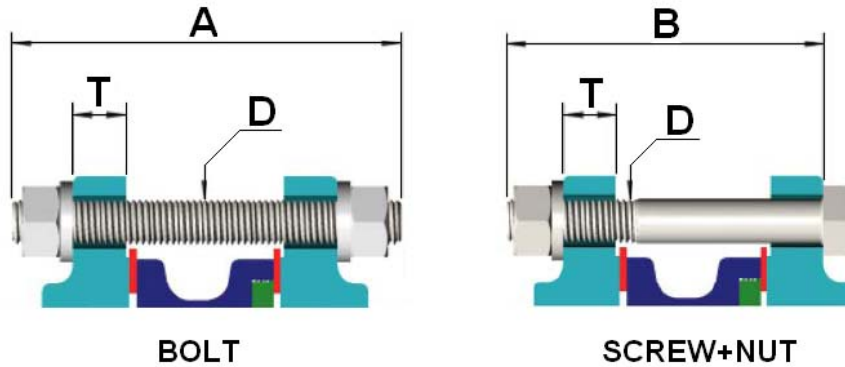

DN	50	65	80	100	125	150	200	250	300	350	400	450	500	600
NPS	2"	2"1/2	3"	4"	5"	6"	8"	10"	12"	14"	16"	18"	20"	24"
A	135	135	140	155	175	175	185	200	215	230	265	290	305	360
B	125	125	130	140	155	155	165	180	195	205	240	265	280	330
D	M16	M16	M16	M16	M20	M20	M20	M24	M24	M27	M27	M30	M30	M33
T	22	22	24	24	26	28	30	32	34	38	40	48	48	58

**GEARBOX SPECIFICATIONS :**

DN	50-65	80	100	125-150	200-250	300-350	400-600
NPS	2"-2"1/2	3"	4"	5"-6"	8"-10"	12"-14"	16"-24"
Ref.	1193001	1193002	1193003	1193004	-	-	-
Ratio factor	40 :1	40 :1	36 :1	36 :1	36 :1	52 :1	70 :1
Number of cycles for opening or closing	10	10	9	9	9	13	17.5
Input torque ( Nm )	24.5	24.5	54	54	109	150	225
Output torque ( Nm )	245	245	490	490	980	1960	3922

**DOUBLE ECCENTRIC BUTTERFLY VALVE CLASS 150 PN20****STANDARDS :**

Fabrication according to ISO 9001:2008

DIRECTIVE 97/23/CE : CE N° 0035  
Risk Category III module H

Designing according to API 609

Marking according to MSS SP-25

Tightness tests according to ISO 5208, range A

Between flanges according to ANSI B16-5 Class 150 (PN20)

ISO 5211 mounting pad

Length according to EN 558 series 20 ( ISO 5752 series 20 )

Fire safe according to ISO 10497 : 2010

ATEX Groupe II Category 2 G/2D Zone 1 & 21 Zone 2 & 22 ( Optional marking )

Approval certificate Russian Federation **GOST-R**

**ADVICE :** Our opinion and our advice are not guaranteed and SFERACO shall not be liable for the consequences of damages.  
The customer must check the right choice of the products with the real service conditions.



**DOUBLE ECCENTRIC BUTTERFLY VALVE CLASS 150 PN20****INSTALLATION INSTRUCTIONS****GENERAL GUIDELINES :**

Ensure that the valves to be used are appropriate for the conditions of the installation (type of fluid, pressure and temperature).

Be sure to have enough valves to be able to isolate the sections of piping as well as the appropriate equipment for maintenance and repair.

Ensure that the valves to be installed are of correct strength to be able to support the capacity of their usage.

**Installation of all circuits should ensure that their function can be automatically tested on a regular basis (at least two times a year).**

**INSTALLATION INSTRUCTIONS :**

**Before installing the valves, clean and remove any objects from the pipes** (in particular bits of sealing and metal) which could obstruct and block the valves.

**Ensure that both connecting pipes either side of the valve (upstream and downstream) are aligned (if they're not, the valves may not work correctly).**

**Make sure that the two sections of the pipe (upstream and downstream) match, the valve unit will not absorb any gaps. Any distortions in the pipes may affect the tightness of the connection, the working of the valve and can even cause a rupture.** To be sure, place the kit in position to ensure the assembling will work.

**If sections of piping do not have their final support in place, they should be temporarily fixed. This is to avoid unnecessary strain on the valve.**

Tighten the bolts in cross.

The disc must move easily inside the pipe.

Valves must be opened during cleaning operation.

Tests must be done with a cleaned pipe.

Tests must be done with opened valve. Test pressure must not be higher than the valve specification according to ISO 5208.

Then open slowly the valve.

**Do not mount butterfly valves with stainless steel pressed collars and turning flanges without strias.**

**And not on flat face flanges without strias ( example : painted cast iron fittings )**

**MAINTENANCE :**

We recommend to operate fully the valve 1 to 2 times per year.

During maintenance operation, ensure that the pipe isn't under pressure, that there's no fluid in the pipe and that the valve is isolated. If there's a fluid in the pipe, evacuate it. Ensure that there are no risks due to the temperature or the fluid ( like acids ). If the fluid is corrosive, inert the installation before maintenance operation.