

WAFER BUTTERFLY VALVE MODEL 1155



PED 97/23/CE



Size:	DN 32/40 to DN 300
Ends:	Between flanges PN 10/16, Class 150 (PN 20)
Min Temperature:	-25 °C
Max temperature:	+200°C
Max pressure:	16 Bars up to DN 150
Specifications:	Long neck for isolation Wafer type 2 parts body ISO 5211 mounting pad
Materials:	Ductile iron EN GJS 500-7 body

WAFER BUTTERFLY VALVE MODEL 1155

SPECIFICATIONS:

- Long neck for isolation
- ISO 5211 mounting pad
- Wafer type
- Between flanges PN 10/16 from DN 32/40 to DN 300 and Class 150 (PN 20) from DN 40 to DN 300
- 2 parts body
- 2 parts stem
- PTFE seat 3 mm thickness with silicone elastic gasket 6 mm thickness
- Stainless steel PTFE coated disc
- 9 positions lever with locking device up to DN200
- Rilsan coated body color RAL 5024, 250-300 microns thickness
- Stem extension 75 mm length (option)
- Square lever 30x30 mm for special key (option)

USE:

- For corrosive fluids (acids ...)
- Min and max Temperature T_s : - 25°C to + 200°C
- Max Pressure P_s : 16 bars up to DN150, 10 bars over (see graph under)

RANGE:

- With lever from DN 32/40 to DN 200
- With IP65 gear box from DN 250 to DN 300 (possible from DN 32/40 to DN200: Ref. 1197)
- On request, IP65 chain gear box (Ref. 1194) from DN 32/40 to DN 300
- On request, stem extension with special length (Ref. 98665)
- On request, stainless steel lever and bolting (Ref. 9831250-9831264)

ENDS :

- Between flanges PN 10/16 from DN 32/40 to 300 and Class 150 (PN 20) from DN 40 to 300

PRESSURE / TEMPERATURE GRAPH (STEAM EXCLUDED):

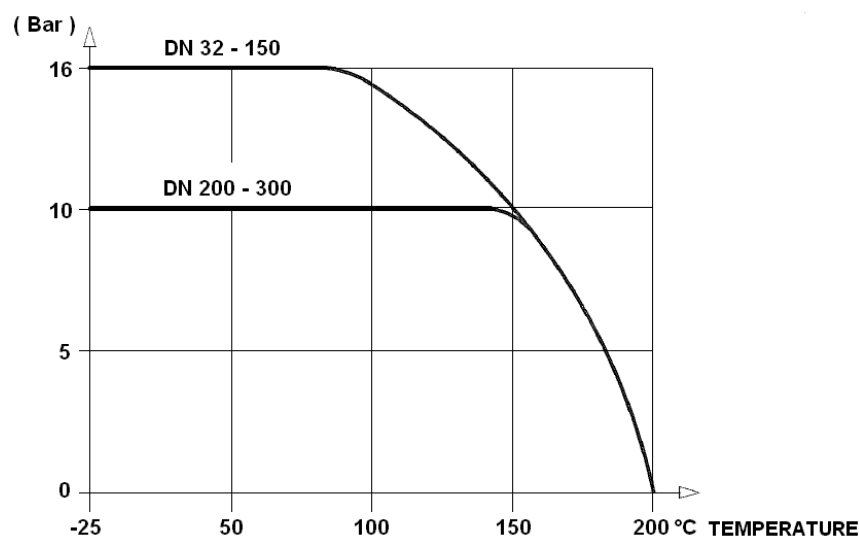

WAFER BUTTERFLY VALVE MODEL 1155

TORQUE VALUES (in Nm with safety coefficient of 30 % included) at 10 Bars:

DN	32/40	50	65	80	100	125	150	200	250	300
Torque (Nm)	25	40	45	75	90	160	180	230	475	680

FLOW COEFFICIENT Kvs (m³ / h):

DN	32/40	50	65	80	100	125	150	200	250	300
Kvs (m ³ /h)	70	109	200	334	551	901	1427	2383	3825	5659

HEAD LOSS GRAPH:

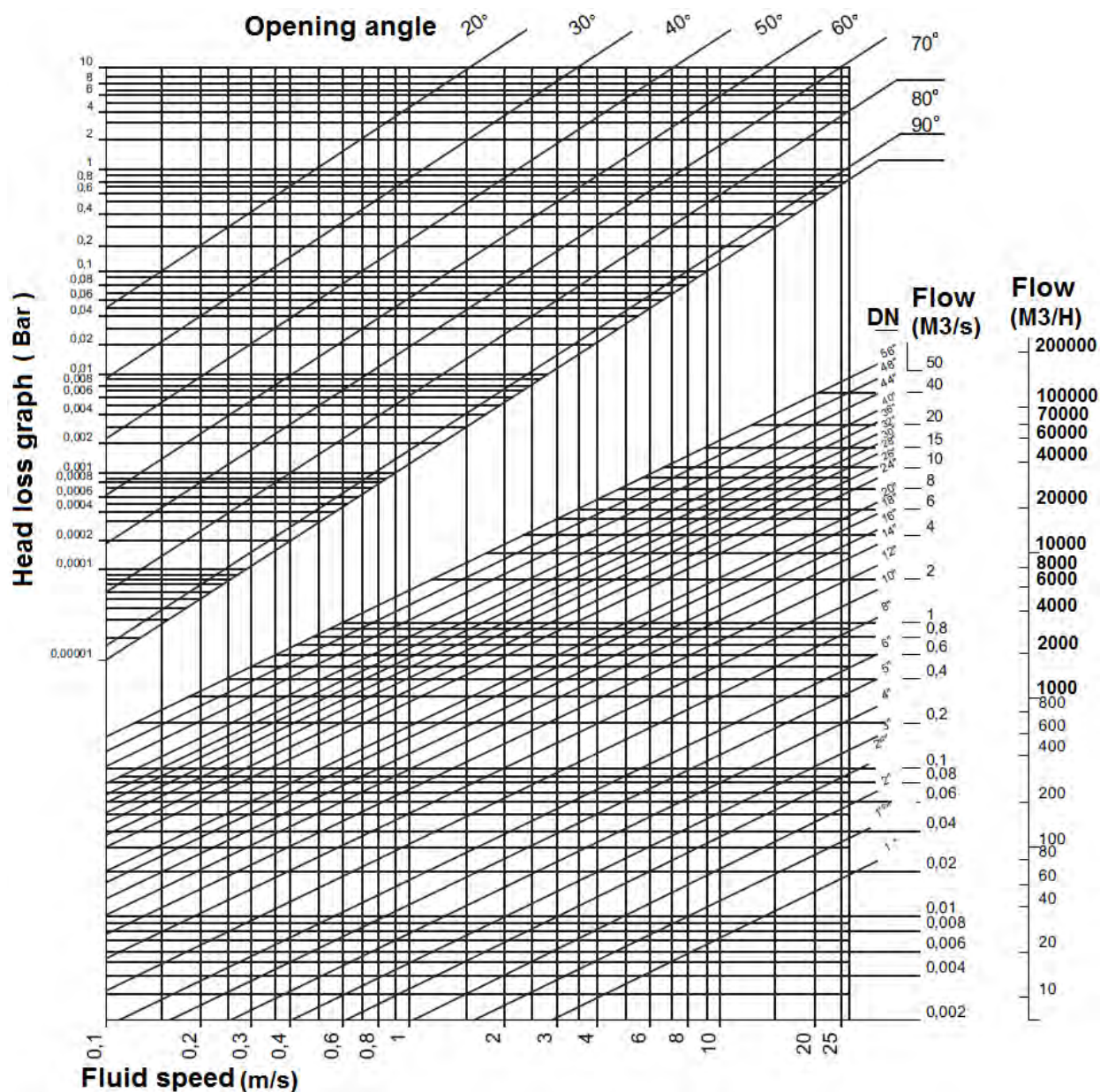

WAFER BUTTERFLY VALVE MODEL 1155

MATERIALS:

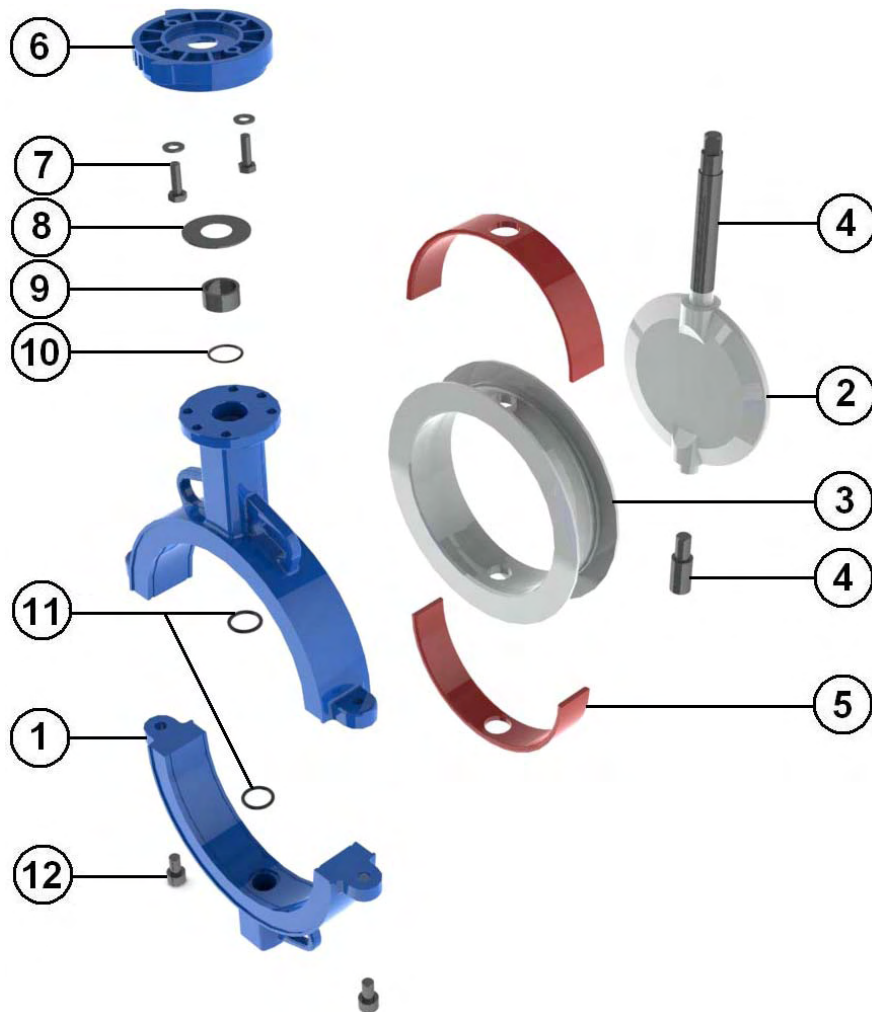

Item	Designation	Materials
1	Body	Ductile iron EN GJS-500-7
2	Disc	ASTM A351 CF8M PTFE coated
3	Seat	PTFE
4	Stem	SS 316
5	Insert	Silicone
6	Plate	Aluminium
7	Plate screw	A4
8	Ring	SS 316
9	Socket	SS 316
10	O ring	FKM
11	O ring	FKM
12	Body screw	A4
	Lever	Aluminium ADC10 with epoxy painting 50µ thickness

WAFER BUTTERFLY VALVE MODEL 1155

GEARBOX MATERIALS REF. 1197:

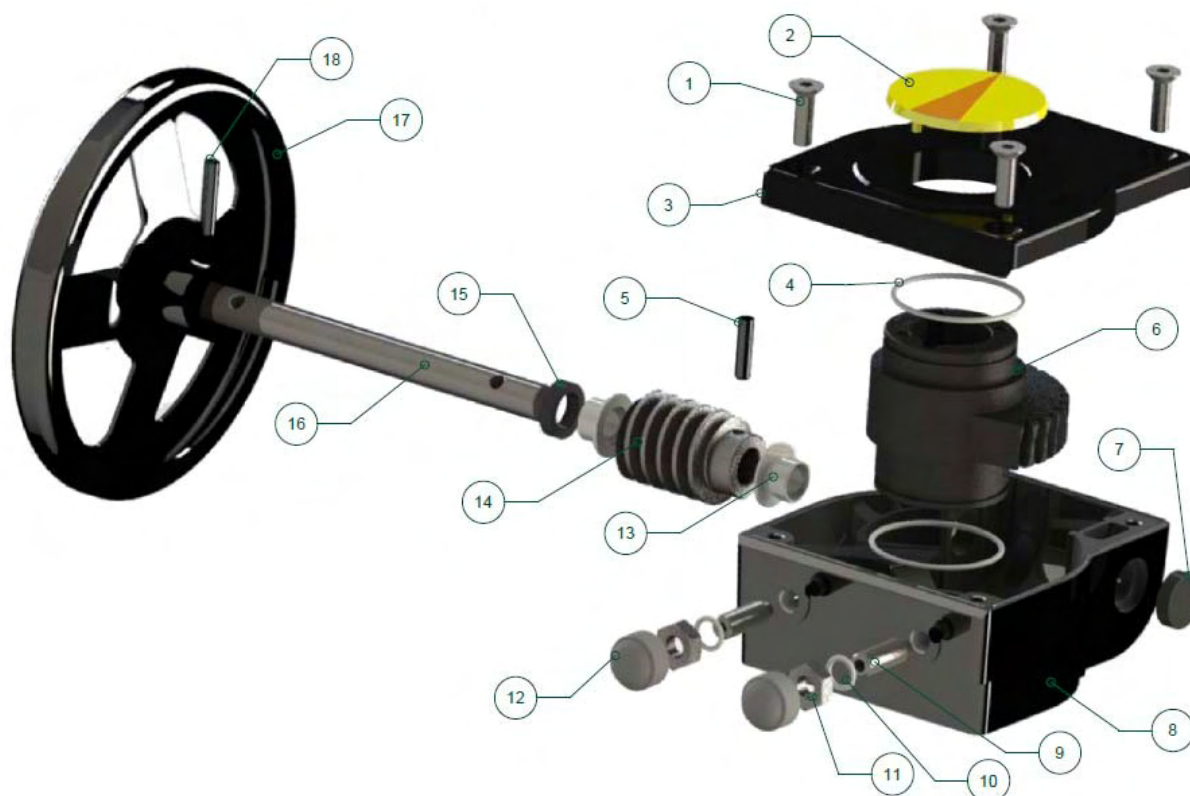

Item	Designation	Materials Ref. 1197
1	Screw	SS 304
2	Indicator	Polypropylene
3	Cover	Aluminium
4	O ring	NBR
5	Pin	Carbon steel
6	Quadrant	Ductile iron EN GJS-400-15
7	Gasket	NBR
8	Body	Aluminium
9	Adjusting bolt	Carbon steel
10	Washer	Galvanized steel
11	Nut	Galvanized steel
12	Cap	NBR 70
13	Bushing	Bronze
14	Worm	Carbon steel 45
15	Gasket	NBR
16	Shaft	Carbon steel 45
17	Handwheel	Carbon steel
18	Pin	Carbon steel

WAFER BUTTERFLY VALVE MODEL 1155

SIZE PN 10 (in mm):

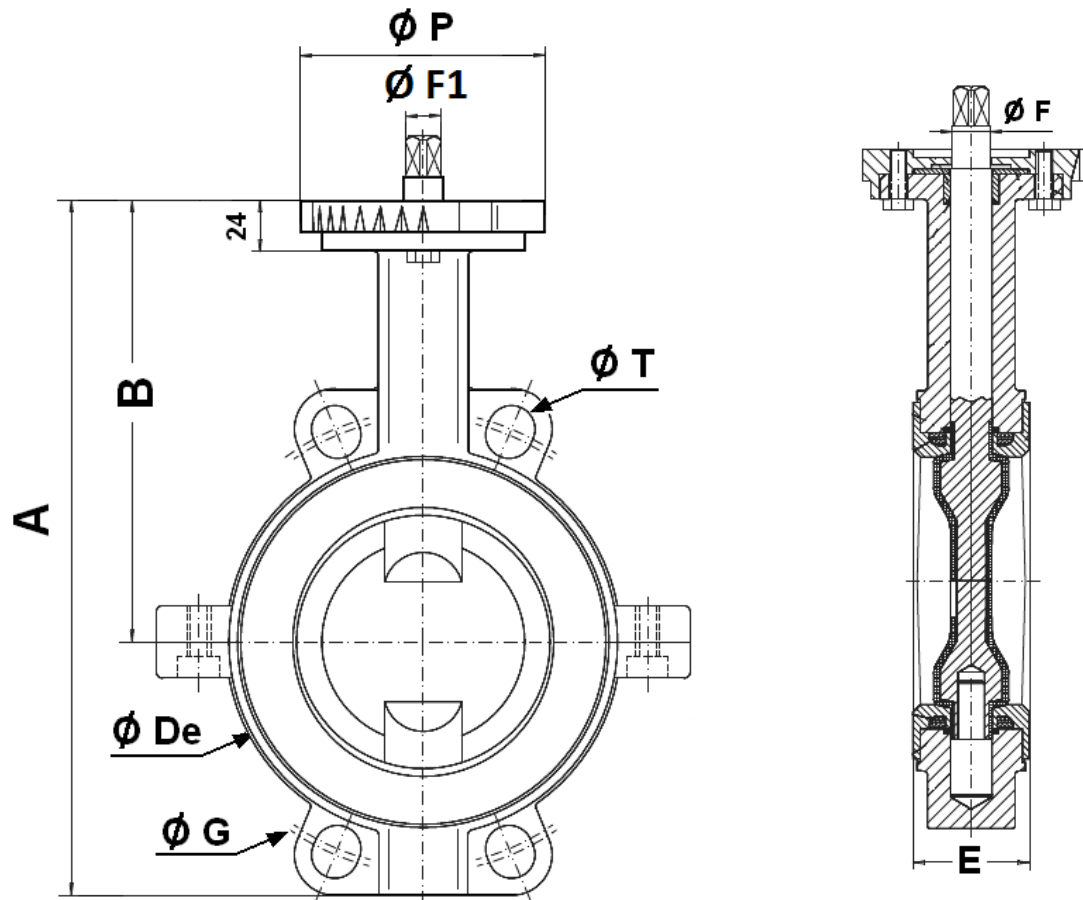

DN	32/40	50	65	80	100	125	150	200
A	205	226	242	262	290	326	348	438
B	140	156	161	167	184	207	215	257
Ø De	83	103	117	134	150	185	205	270
E	33	43	46	46	52	56	56	60
Ø F	10	10	14	16	16	18	18	22
Ø F1	9,5	9,5	12	14	14	17	17	21
Ø G	110	125	145	160	180	210	240	295
Ø P	88	88	88	88	88	105	105	105
Ø T	18	18	18	18	18	18	23	23
Kg	2,5	4	4,57	5,18	6,5	9,5	10,37	16,8

WAFER BUTTERFLY VALVE MODEL 1155

SIZE PN 10 (in mm) DN 250 - 300:

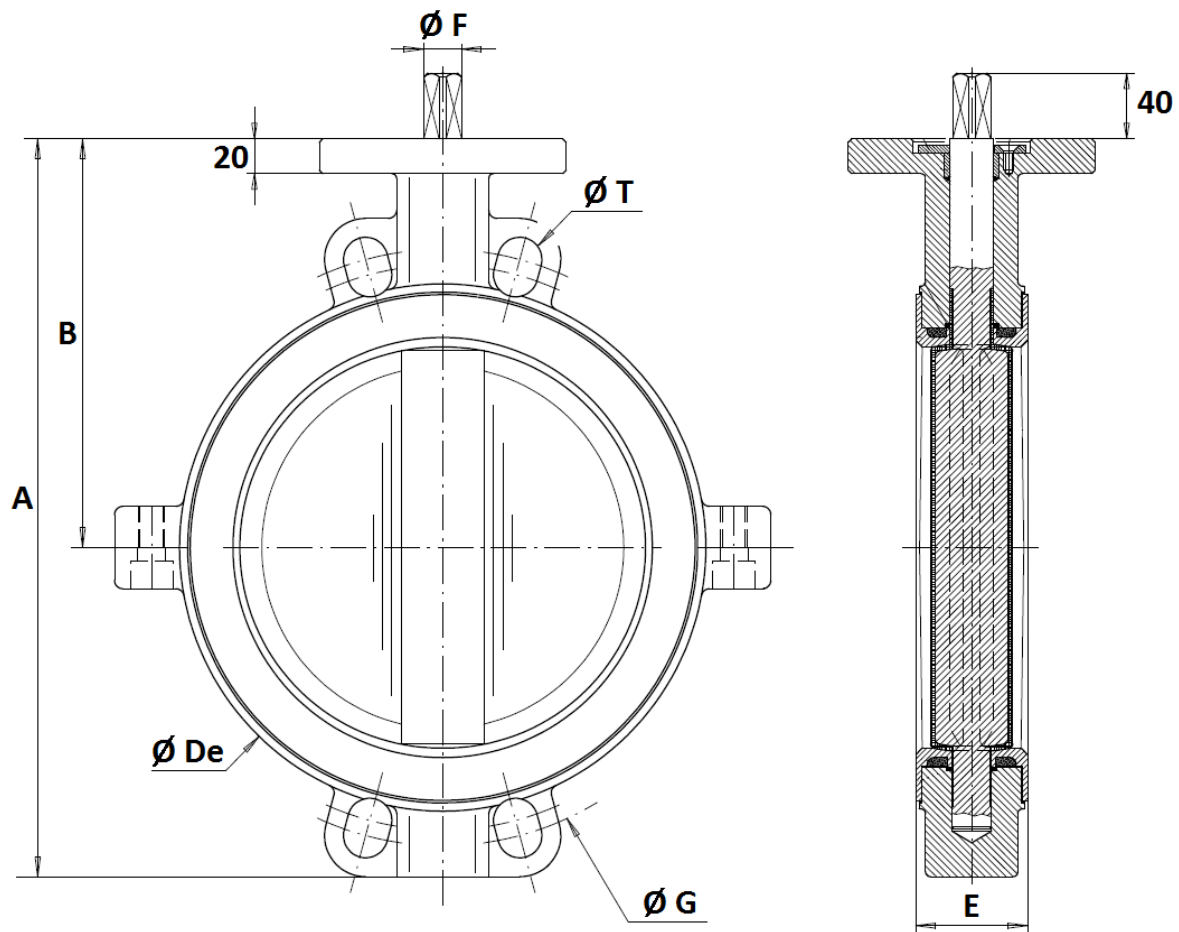

DN	250	300
A	448	514
B	248	280
Ø De	320	373
E	68	78
Ø F	23	26,5
Ø G	350	400
Ø P	150	150
Ø T	23	23
Kg	31	42

WAFER BUTTERFLY VALVE MODEL 1155

LEVER SIZE (in mm):

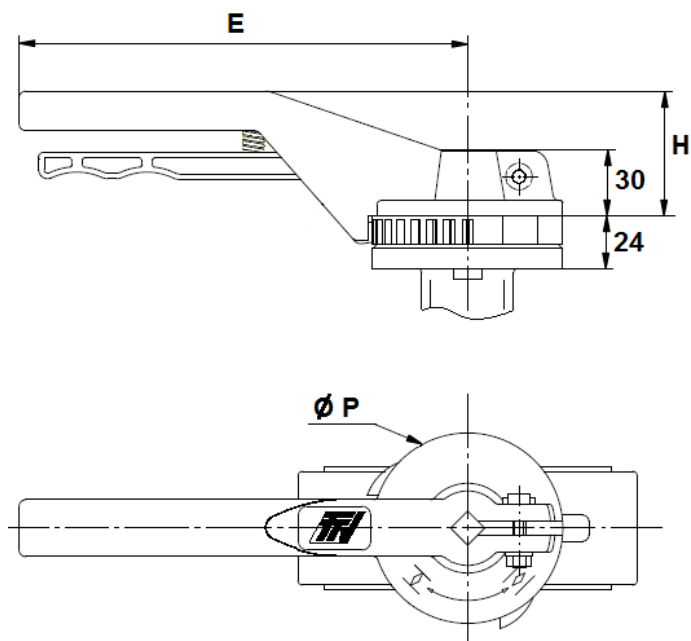

DN	32 - 100	125 - 200
E	205	330
H	57	70
Ø P	88	105

WAFER BUTTERFLY VALVE MODEL 1155

SIZE PN10 (in mm):

Valves with gear box:

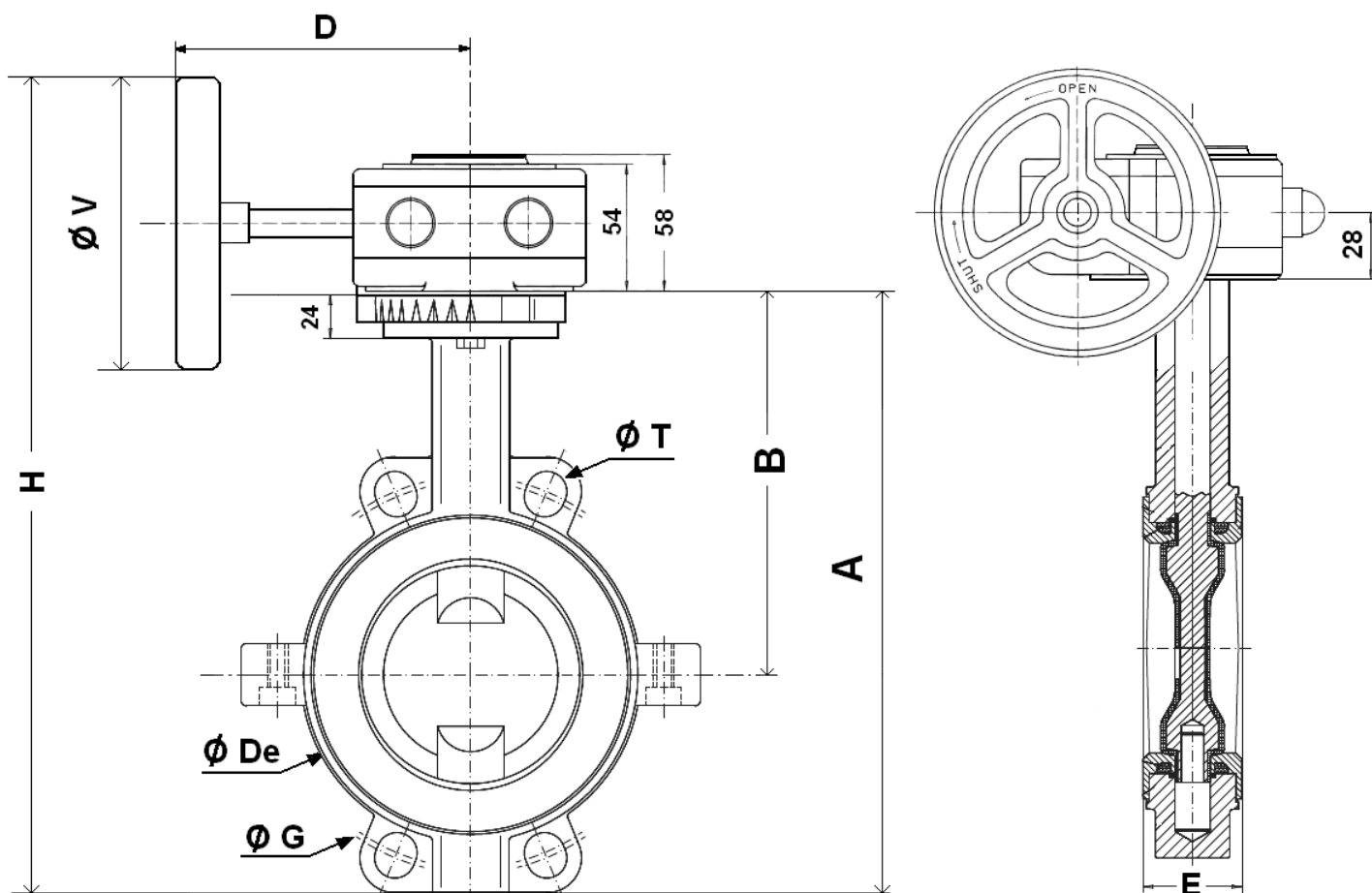

DN	32/40	50	65	80	100	125	150	200	250	300
A	205	226	242	262	290	326	348	438	448	514
B	140	156	161	167	184	207	215	257	248	280
Ø De	83	102	119	135	155	185	208	270	320	373
D	120	120	120	120	120	136	136	136	223	223
E	33	43	46	46	52	56	56	60	68	78
H	304	326	341	364	392	452	477	566	634	701
Ø G	110	125	145	160	180	210	240	295	350	400
Ø T	18	18	18	18	18	18	23	23	23	23
Ø V	140	140	140	140	140	200	200	200	300	300
Kg	3,85	5,35	5,92	6,53	7,85	11,25	12,12	18,55	35	46

WAFER BUTTERFLY VALVE MODEL 1155

SIZE PN10 (in mm):

Valves with chain gear box:

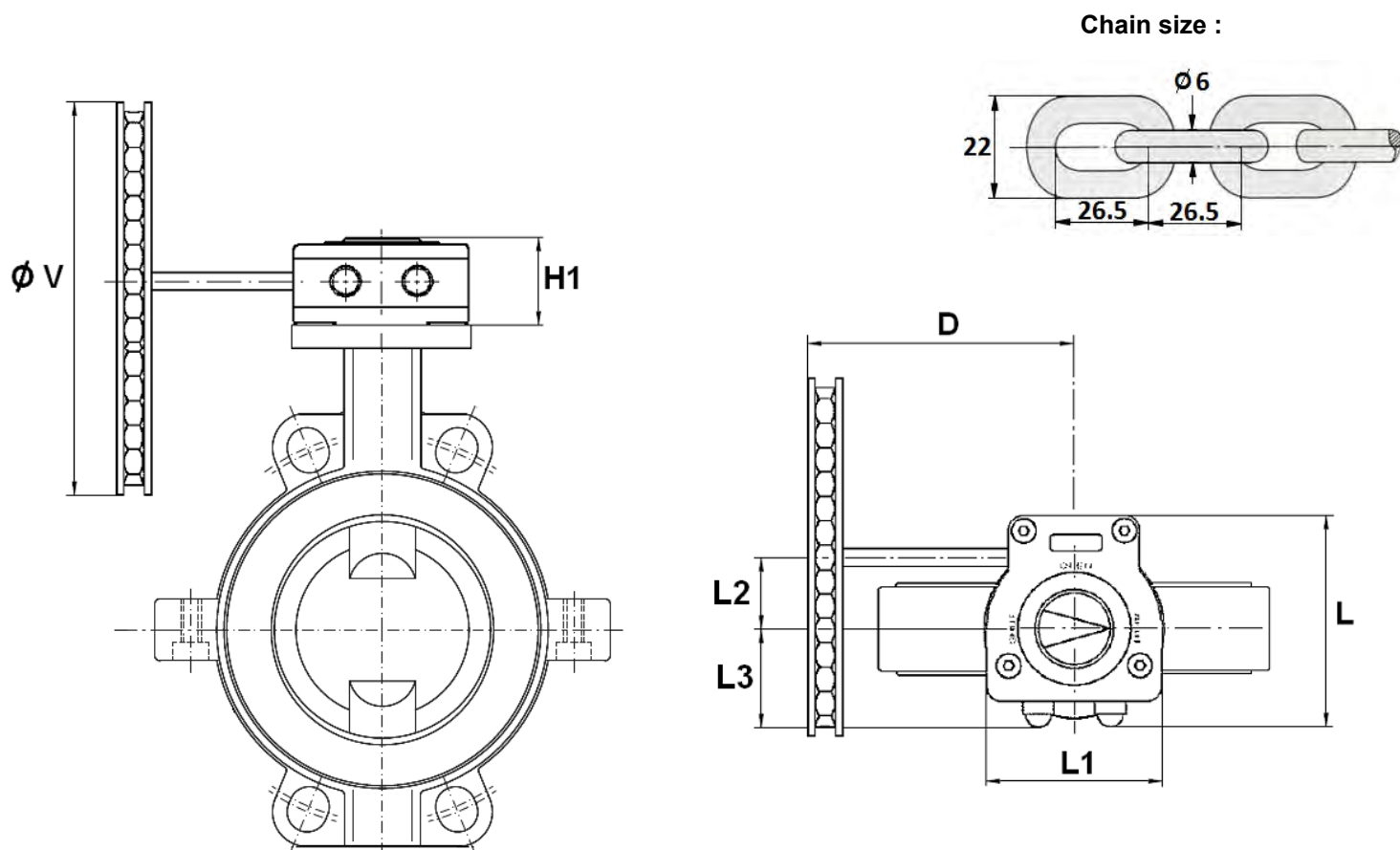

DN	32/40	50	65	80	100	125	150	200	250	300
D	120	120	120	120	120	126	126	126	214	214
H1	58	58	58	58	58	58	58	58	74	74
L	128	128	128	128	128	128	128	128	175	175
L1	100	100	100	100	100	100	100	100	142	142
L2	50	50	50	50	50	50	50	50	61	61
L3	56	56	56	56	56	56	56	56	80	80
Ø V	160	160	160	160	160	210	210	210	300	300
Kg	4,85	6,35	6,92	7,53	8,85	12,25	13,12	19,55	37,8	48,8

WAFER BUTTERFLY VALVE MODEL 1155

GEARBOX SPECIFICATIONS:

DN	32/50	65	80/100	125/150	200	250	300
Ref.	1197050	1197065	1197100	197150	1197200	1197250	1197300
Ratio factor	37 : 1	37 : 1	37 : 1	37 : 1	37 : 1	36 : 1	36 : 1
Number of cycles for opening or closing	9,25	9,25	9,25	9,25	9,25	9	9
Input torque (Nm)	12,5	12,5	12,5	12,5	12,5	23	23
Output torque (Nm)	300	300	300	300	300	675	675

DISC AND NECK SIZE (in mm):

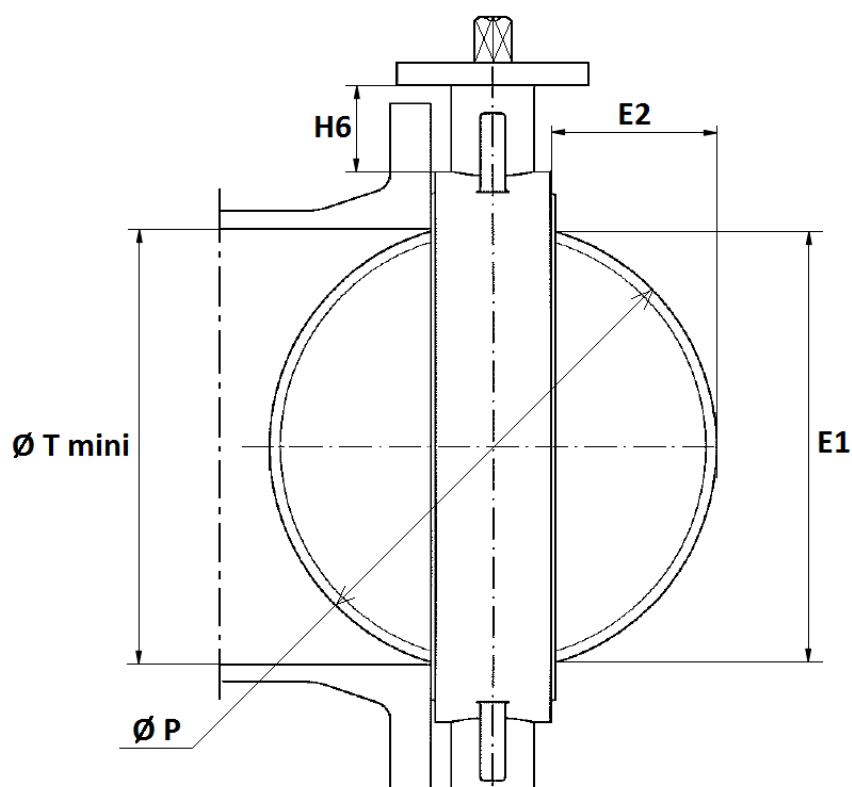

DN	32/40	50	65	80	100	125	150	200	250	300
E1	23	24,5	46	65	85	109	136	188	238	289
E2	3,5	3,5	9,5	17	24	33,5	45,5	69	90	110,5
H6	76	82	80	80	88	93	89	99	71	76
Ø T min	26	27,5	49	68	88	112	139	191	241	292
Ø P	40	50	65	80	100	123	147	198	248	299

WAFER BUTTERFLY VALVE MODEL 1155

SIZE (in mm):

Square lever for special key (30x30 mm)

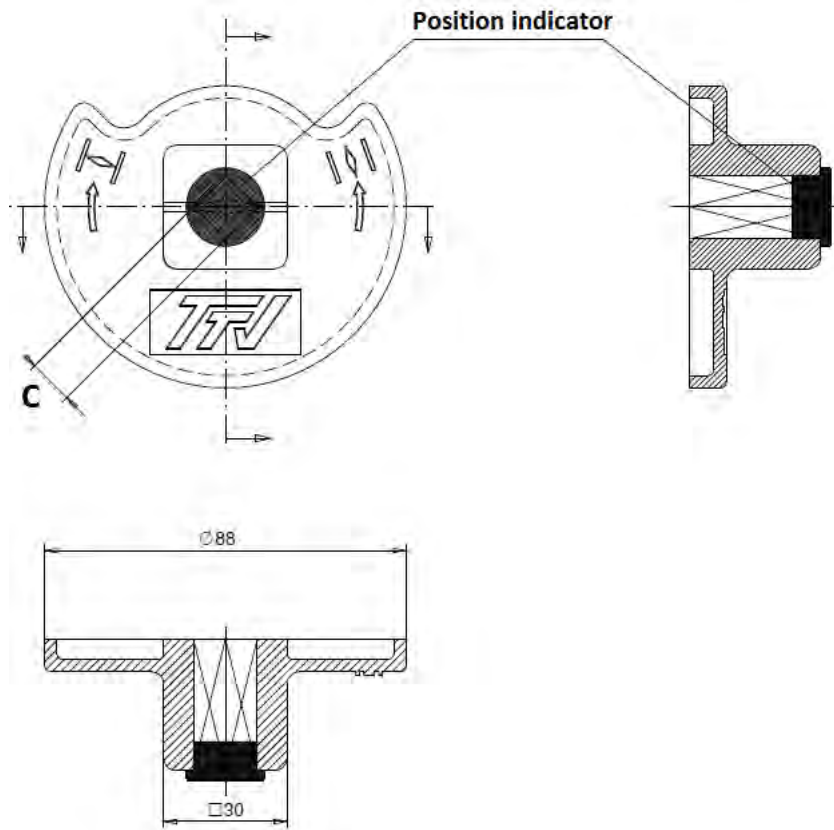

DN	32/50	65	80/100	125/150	200
C	8 x 8	9 x 9	11 x 11	14 x 14	17 x 17

WAFER BUTTERFLY VALVE MODEL 1155

ISO MOUNTING PAD AND STEM SIZE (in mm):

DN 40 - 200

DN 250 - 300

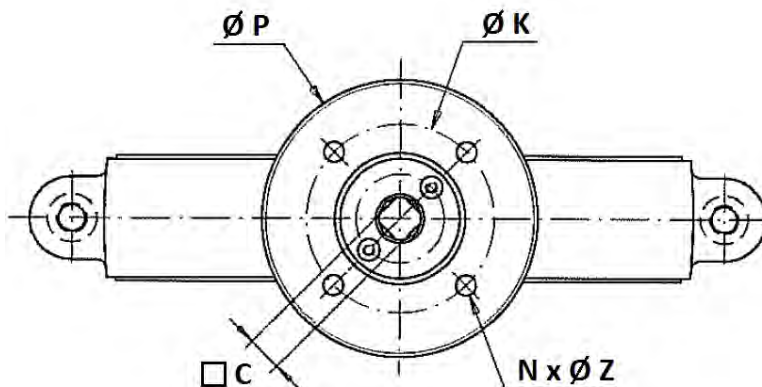
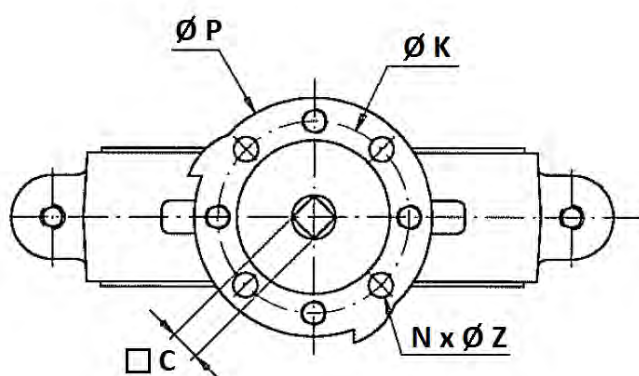
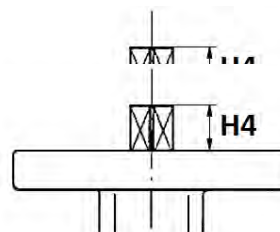
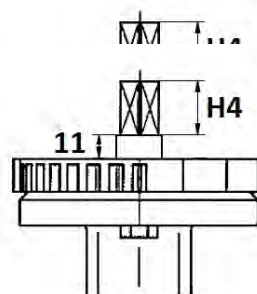

DN	32/40	50	65	80	100	125	150	200	250	300
H4	19	19	19	19	19	19	19	19	40	40
C	8	8	9	11	11	14	14	17	19	22
Ø K	70	70	70	70	70	70	70	70	102	102
ISO	F07	F07	F07	F07	F07	F07	F07	F07	F10	F10
N x Ø Z	4 x 9	4 x 9	4 x 9	4 x 9	4 x 9	4 x 9	4 x 9	4 x 9	4 x 11	4 x 11
Ø P	88	88	88	88	88	105	105	105	150	150

WAFER BUTTERFLY VALVE MODEL 1155

STANDARDS :

- Fabrication according to ISO 9001:2008
- Designing according to ISO 10631
- DIRECTIVE 97/23/CE: CE N° 0038 Risk Category III module H
- Tests according to ISO 5208, A class
- Between flanges according to EN 1092-1 PN 10 / 16
- ISO 5211 mounting pad
- Length according to ISO 5752 short series 20, EN 558 series 20 (NF 29305), BS 5155 Wafer short/medium, DIN 3202 part 3, series K1
- ATEX Group II Category 2 G/2D Zone 1 & 21 Zone 2 & 22 (optional marking)
- FDA PTFE seat
- PTFE seat compatible with foodstuffs according to the rule CE 1935/2004 (article 3)
- ADVICE: Our opinion and our advice are not guaranteed and SFERACO shall not be liable for the consequences of damages.

The customer must check the right choice of the products with the real service conditions.

WAFER BUTTERFLY VALVE MODEL 1155

GENERAL GUIDELINES:

- Ensure that the valves to be used are appropriate for the conditions of the installation (type of fluid, pressure and temperature).
- Be sure to have enough valves to be able to isolate the sections of piping as well as the appropriate equipment for maintenance and repair.
- Ensure that the valves to be installed are of correct strength to be able to support the capacity of their usage.
- Installation of all circuits should ensure that their function can be automatically tested on a regular basis (at least two times a year).

INSTALLATION INSTRUCTIONS:

- Before installing the valves, clean and remove any objects from the pipes (in particular bits of sealing and metal) which could obstruct and block the valves.
- Ensure that both connecting pipes either side of the valve (upstream and downstream) are aligned (if they're not, the valves may not work correctly).
- Make sure that the two sections of the pipe (upstream and downstream) match, the valve unit will not absorb any gaps. Any distortions in the pipes may affect the tightness of the connection, the working of the valve and can even cause a rupture.
To be sure, place the kit in position to ensure the assembling will work.
- If sections of piping do not have their final support in place, they should be temporarily fixed. This is to avoid unnecessary strain on the valve.
- The valve must be inserted between flanges with disc half opened but the disc must not overpass the valve thickness. Position the bolts to keep centered the valve.
Then open fully the valve and tighten the bolts. See graph under.

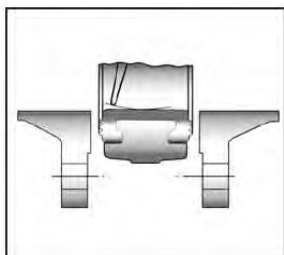

Half open valve introduction

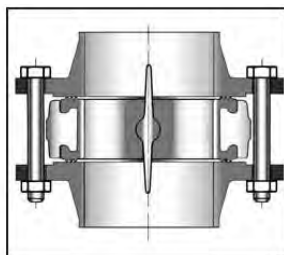

Complete opened disc valves when screw tightening

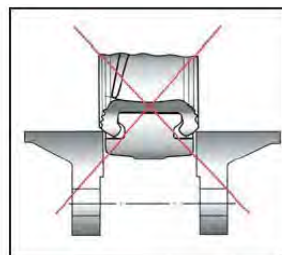

- Tighten the bolts in cross.
- The disc must move easily inside the pipe.
- Valves must be opened during cleaning operation.
- Tests must be done with a cleaned pipe.
- Tests must be done with opened valve.
- Test pressure must not be higher than the valve specification according to ISO 5208.
- Then open slowly the valve.
- Do not mount butterfly valves with stainless steel pressed collars and turning flanges without strias.
- And not on flat face flanges without strias (example : painted cast iron fittings).

MAINTENANCE :

- We recommend to operate fully the valve 1 to 2 times per year.
- During maintenance operation, ensure that the pipe isn't under pressure, that there's no fluid in the pipe and that the valve is isolated. If there's a fluid in the pipe, evacuate it. Ensure that there are no risks due to the temperature or the fluid (like acids).
If the fluid is corrosive, inert the installation before maintenance operation.