



## Model 147



For liquids, gases and steam.

For use in hydraulic, pneumatic, heating and steam systems, chemical and food industries, etc.

### Specifications:

- Mobile or floating closure.
- Reduced pitch.
- Lightly tightening the handwheel guarantees it is perfectly tightness, which exceeds the standard DIN-3230. Sheet 3.
- Axis with rear closure „back seating“ which allows the packing to be changed while in use and thus avoids it having any contact - with the fluid.
- Fully constructed from laminated bars.

### IMPORTANT:

Depending on demand:

- Possibility of manufacture in other types of material, for use in special working conditions (high temperatures, fluids, etc.).
- PTFE (Teflón) packing.
- Stainless steel handwheel or handle (DIN-1.4401) (AISI-316) or other connections.

No.	Piece	Material											
		Brass			Carbon steel				Stainless steel				
1	Body	Brass (DIN-1.7660 CuZn40Pb2)			C. steel (DIN-1.1191 Ck-45)				S. steel (DIN-1.4401) (AISI-316)				
2	Closure	S. steel (DIN-1.4401) (AISI-316)			S. steel (DIN-1.4401) (AISI-316)				S. steel (DIN-1.4401) (AISI-316)				
3	Stuffing box body	Brass (DIN-1.7660 CuZn40Pb2)			C. steel (DIN-1.1191 Ck-45)				S. steel (DIN-1.4401) (AISI-316)				
4	Ring	S. steel (DIN-1.4401) (AISI-316)			S. steel (DIN-1.4401) (AISI-316)				S. steel (DIN-1.4401) (AISI-316)				
5	Packing	Graphite			Graphite				Graphite				
6	Stuffing box	Brass (DIN-1.7660 CuZn40Pb2)			C. steel (DIN-1.1191 Ck-45)				S. steel (DIN-1.4401) (AISI-316)				
7	Stuffing box nut	Brass (DIN-1.7660 CuZn40Pb2)			C. steel (DIN-1.1191 Ck-45)				S. steel (DIN-1.4401) (AISI-316)				
8	Axis	S. steel (DIN-1.4401) (AISI-316)			S. steel (DIN-1.4401) (AISI-316)				S. steel (DIN-1.4401) (AISI-316)				
9	Handwheel (1)	C. steel (DIN-1.0517 MU ST-3)			C. steel (DIN-1.0517 MU ST-3)				C. steel (DIN-1.0517 MU ST-3)				
10	Plate	Aluminium			Aluminium				Aluminium				
11	Nut	S. steel (DIN-1.4401) (AISI-316)			S. steel (DIN-1.4401) (AISI-316)				S. steel (DIN-1.4401) (AISI-316)				
12	Washer	S. steel (DIN-1.4401) (AISI-316)			S. steel (DIN-1.4401) (AISI-316)				S. steel (DIN-1.4401) (AISI-316)				
<b>DN</b>		1/4" to 2" (GAS, NPT or SW)											
<b>PN</b>		200			250				250				
Operating conditions	Pressure (bar)	200	175	34	250	211	180	167	250	207	170	164	
	Max. temp. °C	120	150	200	120	300	350	400	120	200	350	400	
	Min. temp. °C	-60			-10				-60				

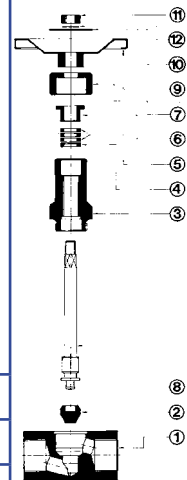

(1) The 1/4" to 1 1/4" handwheels are supplied in Aluminium (DIN-3.2581.01 G-AISI12).



R		1/4"	3/8"	1/2"	3/4"	1"	1 1/4"	1 1/2"	2"	
Connections		Whitworth gas-tight cylindrical female thread ISO 228/1 1978 (DIN-259)								
		NPT thread ANSI - B 2.1								
		Socket welding ends SW ANSI - B 16.11								
H		77	89	102	111	132	158	172	191	
h <sup>1</sup>		83	94	111	121	146	173	192	216	
L		50	55	65	75	90	95	100	112	
D		60	60	75	75	90	100	125	125	
Reduced pitch Ø		6,00	8,00	9,50	11,50	15,00	17,00	21,00	25,0	
Weight (kg)	Brass	0,38	0,65	0,98	1,12	2,58	3,36	4,59	7,76	
	Carbon steel	0,35	0,50	0,92	1,05	2,40	3,16	4,31	7,22	
	Stainless steel	0,36	0,51	0,93	1,06	2,43	3,20	4,36	7,31	
Code	Brass 2004-147.	GAS	0041	0381	0021	0341	0101	0141	0121	0201
		NPT	00411	03811	00211	03411	01011	01411	01211	02011
	Carbon steel 2004-147.	GAS	0044	0384	0024	0344	0104	0144	0124	0204
		NPT	00441	03841	00241	03441	01041	01441	01241	02041
		SW	00442	03842	00242	03442	01042	01442	01242	02042
	Stainless steel 2004-147.	GAS	0042	0382	0022	0342	0102	0142	0122	0202
		NPT	00421	03821	00221	03421	01021	01421	01221	02021
		SW	00422	03822	00222	03422	01022	01422	01222	02022

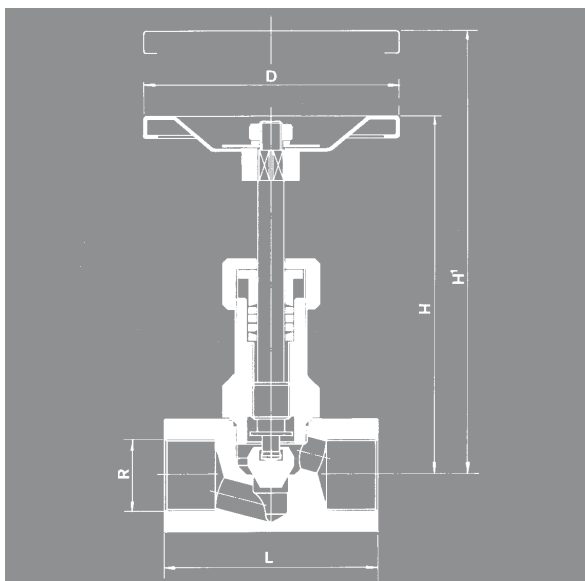

DN	Flow coefficient	
	Kv m <sup>3</sup> /h Δp = 1 bar	Cv l/min Δp = 1 Psi = 0,07 bar
1/4"	0,68	3,00
3/8"	1,11	5,00
1/2"	2,16	10,10
3/4"	4,10	18,80
1"	6,20	25,00
1 1/4"	9,80	43,00
1 1/2"	12,95	52,00
2"	19,40	82,00

### Load losses:

The adjoining diagram reflects the load loss curves for water at 20°C.

In order to determine other fluids load losses, calculate the flow of these equivalent to water.

$$Q_a = \sqrt{(q/1000)} * Q$$

- Q<sub>a</sub> Flow equivalent to water in m<sup>3</sup>/h
- q Fluid density in operating conditions Kg/m<sup>3</sup>
- Q Fluid flow in operating conditions m<sup>3</sup>/h

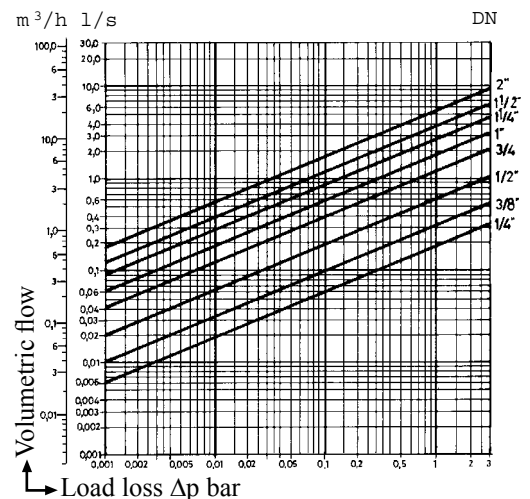



## Pin cock

AISI 316L

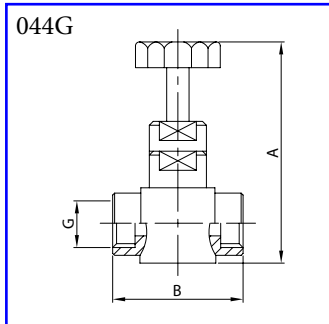

DN	A	B	G	Kg
14	84,0	45,0	1/4"	0,50
38	105,0	52,0	3/8"	0,53
12	121,0	61,0	1/2"	0,57
34	132,0	68,0	3/4"	0,60
100	150,0	86,0	1"	0,63

## Square valve

AISI 316L

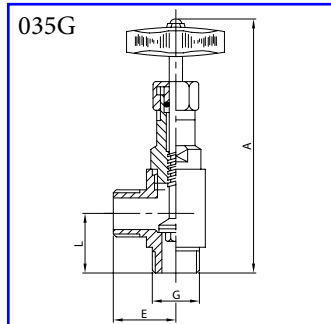

DN	A	E	G	L	Kg
14	96,0	23,0	1/4"	23,0	0,20
38	154,0	27,5	3/8"	27,5	0,35
12	178,0	35,0	1/2"	35,0	0,65
34	195,0	40,5	3/4"	40,5	0,95
100	225,0	48,0	1"	48,0	1,30