

STAINLESS STEEL STIRRUPS

Stirrup - short (including nuts)
material: DIN 1.4301
on request: DIN 1.4404 / 1.4571 ...

Stirrup - middle (including nuts)
material: DIN 1.4301
on request: DIN 1.4404 / 1.4571 ...

Stirrup - long (including nuts)
material: DIN 1.4301
on request: DIN 1.4404 / 1.4571 ...

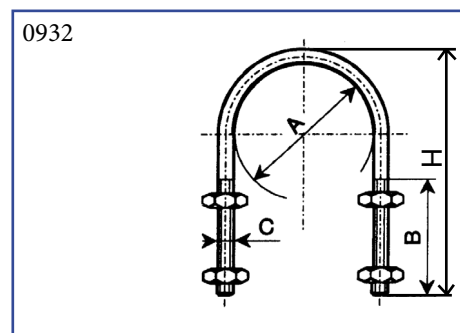
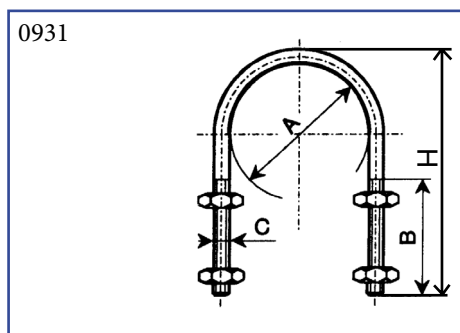
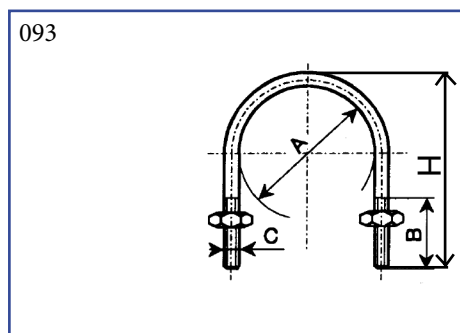

ordering code DIN 1.4301*	Ø A	B	Ø C	H **	Kg
093-012-1.4301	12 / 13		5		0,01
093-018-1.4301	17,2 / 18 / 19	25	6	48	0,02
093-022-1.4301	21,3 / 22 / 23	25	6	50	0,03
093-025-1.4301	25,4	30	6	55	0,04
093-026-1.4301	26,9	30	6	59	0,04
093-028-1.4301	28 / 29	30	6	59	0,04
093-034-1.4301	33,7 / 34 / 35	30	6	65	0,05
093-038-1.4301	38,1	30			0,06
093-040-1.4301	40 / 41	30	8	78	0,08
093-042-1.4301	42,4	30	8	82	0,08
093-048-1.4301	48,3	30	8	88	0,09
093-052-1.4301	50,8 / 52 / 53	30	8	87	0,09
093-060-1.4301	60,3	30	8	94	0,10
093-063-1.4301	63,5	30	8		0,10
093-070-1.4301	70	30	8	101	0,11
093-076-1.4301	76,1	30	8	110	0,12
093-085-1.4301	84 / 85	30	10	122	0,20
093-088-1.4301	88,9	30	10	122	0,21
093-101-1.4301	101,6	30	10		0,21
093-104-1.4301	104	30	10	136	0,22
093-108-1.4301	108	30	10		0,23
093-114-1.4301	114,3	30	10	150	0,24
093-129-1.4301	129	30	12		0,40
093-133-1.4301	133	30	12		0,40
093-139-1.4301	139,7	30	12	176	0,45
093-142-1.4301	142	30	12		0,45
093-154-1.4301	154	30	12		0,47
093-159-1.4301	159	30	12		0,48
093-168-1.4301	168,3	30	12		0,50
093-204-1.4301	204	30	12		0,56
093-219-1.4301	219,1	30	12		0,60
093-254-1.4301	254 / 256	*	*	*	*
093-273-1.4301	273	*	*	*	*

ordering code DIN 1.4301*	Ø A	B	Ø C	H **	Kg
0931-012-1.4301	12 / 13	50	5		0,01
0931-018-1.4301	17,2 / 18 / 19	50	6	73	0,02
0931-022-1.4301	21,3 / 22 / 23	50	6	75	0,03
0931-025-1.4301	25,4	50	6	75	0,04
0931-026-1.4301	26,9	50	6	79	0,04
0931-028-1.4301	28 / 29	50	6	79	0,04
0931-034-1.4301	33,7 / 34 / 35	50	6	85	0,06
0931-038-1.4301	38,1	50			0,08
0931-040-1.4301	40 / 41	50	8	98	0,09
0931-042-1.4301	42,4	50	8	102	0,09
0931-048-1.4301	48,3	50	8	108	0,10
0931-052-1.4301	50,8 / 52 / 53	50	8	107	0,10
0931-060-1.4301	60,3	50	8	114	0,12
0931-063-1.4301	63,5	50	8		0,12
0931-070-1.4301	70	50	8	121	0,13
0931-076-1.4301	76,1	50	8	130	0,13
0931-085-1.4301	84 / 85	50	10	142	0,23
0931-088-1.4301	88,9	50	10	142	0,23
0931-101-1.4301	101,6	50	10		0,24
0931-104-1.4301	104	50	10	156	0,25
0931-108-1.4301	108	50	10		0,25
0931-114-1.4301	114,3	50	10	170	0,26
0931-129-1.4301	129	50	12		0,50
0931-133-1.4301	133	50	12		0,50
0931-139-1.4301	139,7	50	12	196	0,55
0931-142-1.4301	142	50	12		0,55
0931-154-1.4301	154	50	12		0,65
0931-159-1.4301	159	50	12		0,65
0931-168-1.4301	168,3	50	12		0,70
0931-204-1.4301	204	50	12		0,70
0931-219-1.4301	219,1	50	12		0,80
0931-254-1.4301	254 / 256	*	*	*	*
0931-273-1.4301	273	*	*	*	*

ordering code DIN 1.4301*	Ø A	B	Ø C	H **	Kg
0932-012-1.4301	12 / 13	80	5		0,02
0932-018-1.4301	17,2 / 18 / 19	80	6		0,03
0932-022-1.4301	21,3 / 22 / 23	80	6		0,04
0932-025-1.4301	25,4	80	6	105	0,05
0932-026-1.4301	26,9	80	6	109	0,05
0932-028-1.4301	28 / 29	80	6	109	0,05
0932-034-1.4301	33,7 / 34 / 35	80	6	115	0,07
0932-038-1.4301	38,1	80			0,10
0932-040-1.4301	40 / 41	80	8	128	0,10
0932-042-1.4301	42,4	80	8	132	0,10
0932-048-1.4301	48,3	80	8	138	0,12
0932-052-1.4301	50,8 / 52 / 53	80	8	137	0,12
0932-060-1.4301	60,3	80	8	144	0,13
0932-063-1.4301	63,5	80	8		0,13
0932-070-1.4301	70	80	8	151	0,15
0932-076-1.4301	76,1	80	8	160	0,20
0932-085-1.4301	84 / 85	80	10	172	0,26
0932-088-1.4301	88,9	80	10	172	0,26
0932-101-1.4301	101,6	80	10		0,26
0932-104-1.4301	104	80	10	186	0,30
0932-108-1.4301	108	80	10		0,30
0932-114-1.4301	114,3	80	10	200	0,30
0932-129-1.4301	129	80	12		0,65
0932-133-1.4301	133	80	12		0,65
0932-139-1.4301	139,7	80	12	226	0,80
0932-142-1.4301	142	80	12		0,80
0932-154-1.4301	154	80	12		0,90
0932-159-1.4301	159	80	12		0,90
0932-168-1.4301	168,3	80	12		1,00
0932-204-1.4301	204	80	12		1,00
0932-219-1.4301	219,1	80	12		1,10
0932-254-1.4301	254 / 256	*	*	*	*
0932-273-1.4301	273	*	*	*	*

* for material DIN 1.4404 use 1.4404 at the end of the code (DIN 1.4571 = 1.4571 etc.)

** H approximate dimensions (consult with the sales department)

Stainless steel stirrups can be also manufactured according to your drawings