



## Metal fused sightglasses type: Triclamp

Metal fused sightglass  
for Triclamp fittings



Metal fused Triclamp sanitary  
sightglass fitting

**Applications:**

- For clamp fittings to DIN 32676 / ISO 2852

**Advantages:**

- Suitable for food processing and sterile applications
- High security
- Easy installation

**Approvals:**

- A3 Standard for food processing

**Technical data:**

- Test base: DGRL 97 / 23 / EG, AD 2000 standards, DIN 7079-1 May 1999
- Materials to VdTÜV specifications and the respective DIN/EN standards

**Material certificates:**

- Certificate of Conformity to EN 10204-3.1

**Operating conditions:**

- Pressure: -1 to 25 bar (see table)
- Temperatures:
 

Ring materials:	1.4462:	- 30 °C to + 280 °C
	2.4602:	- 60 °C to + 300 °C
	2.4610:	- 60 °C to + 300 °C

**Materials:**

- Ring: 1.4462, 2.4602, 2.4610
- Glass quality: Borosilicate to DIN 7080

**Dimensions:**

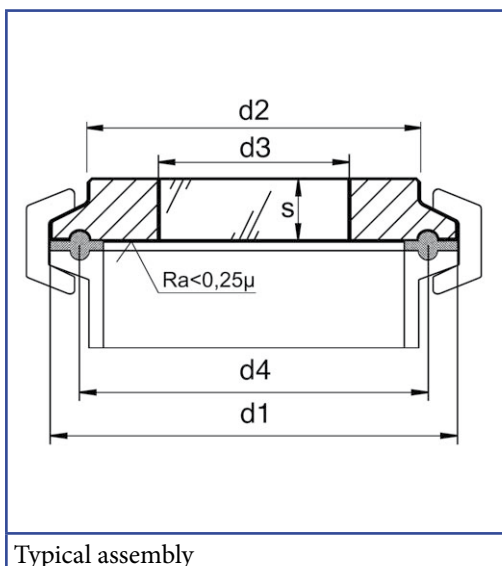

Typical assembly

Nominal diameter			d1	d2	d3	d4	S	Max. operat. pressure (bar)
DN (DIN)	DN (ISO)	ASME-BPE Inch						
-	-	½" / ¾"	25	18	10	20,5	10	25
10/15/20	8/10/15	-	34	21	12	27,5	7	25
25/32/40	20/25/32	1" / 1½"	50,5	41	25	43,5	10	16
50	40	2"	64	52	30	56,5	10	16
-	50	2½"	77,5	69	35	70,5	10	16
65	65	3"	91	76	40	83,5	10	10
80	80	3½"	106	90	50	97	10	10
100	-	4"	119	101	55	110	12	10
-	100	4½"	130	114	60	122	16	10
-	-	5"	144,5	127	65	134,5	16	10
125	-	-	155	138	70	146	16	6
-	-	6"	167	152	75	156,5	16	6
150	-	-	183	160	75	174,3	16	6
-	-	8"	217,5	198	100	207,4	18	6
200	-	-	233,5	210	100	225,1	18	6
-	-	10"	268	245	120	257,8	20	6
250	-	-	287,5	266	120	278,4	20	6
-	-	12"	319,3	300	140	309,1	22	6
300	-	-	338,3	316	140	328,4	22	6

1) All dimensions in mm.

2) Subject to changes without preliminary notice.