



## D-ended sightglass

type: LSG

LSGR

LSGRR

D-ended, elongated sightglass



D-ended, elongated sightglass type LSGRR 316 Ti -304 -2,5-2-SL-8903-KLINGERSil-Silicone. Version with blind tappings, base and cover flange in stainless steel, PN 2,5, glass plate to DIN 8903, seals KLINGERSil C4400 / silicone, dimensions 341 x 116 mm.

### Application:

• Elongated sightglasses VETROLUX® of the series LSG / LSGR / LSGRR may be used to observe the interior of reactors, columns, silos, vessels, storage tanks, pipelines or as liquid level indicators. They are delivered ready to be welded into or onto a vessel wall, complete with appropriate seals, glass plate and cover bolts. The D-end shape facilitates easier machining of the vessel wall prior to welding in the unit.

### Operating conditions:

- Nominal pressure 2,5 / 6 / 10 / 25 bar (see table overleaf)
- Vacuum
- Note: The nominal pressure indicated refers to the design base of the sightglass. When welded into the vessel concerned, the base frame becomes part of the vessel wall. It is necessary, therefore, that appropriate strength calculations are made on all vessels concerned with respect to the design pressure and size of the vessel and in accordance with the relevant design code. If found to be necessary, reinforcement of the vessel wall has to be carried out.

### Operating temperatures:

- 100 °C max. with sodium silicate glass to DIN 8903
- 243 °C max. with borosilicate glass to DIN 7081

Note: The above indicated temperatures refer to the use of unprotected glass plates, with no protective mica sheets..

### Standard materials:

- Base flange: Boiler plate RSt 37-2 / HII / AISI 316Ti / 316L
- Cover flange: Boiler plate RSt 37-2 / HII / AISI 304 / 316Ti / 316L
- Glass plates: Sodium silicate to DIN 8903  
Borosilicate to DIN 7081
- Seals: KLINGERSil C4400 / EPDM / Silicone / PTFE
- Cover bolts DIN 912: Carbon steel, zinked, quality 8.8  
Stainless steel A2-70
- Other materials on request.

### Certificates:

• Against extra charge, material certificates to EN 10204 3.1 / 3.1 AD-W2, as well as glass certificates to EN 10204 2.2 and FDA certificate for gaskets may be supplied. Please formulate your needs already when demanding our quotation.

### Standard version (see left):

- DB Base flange with bolt tappings drilled through (see table overleaf).
- SL Base flange with blind tappings.
- R Base flange with radius back (to correspond to vessel radius).

### Options:

- Version with double glasses (not available for PN 25).
- Fluted glass plate for liquid level indication (only available for PN 25).
- Special dimensions.
- Closed back (base flange) version with drilled and tapped holes at the ends for pipe connections so that the unit may be used as an external gauge of a liquid level.

### Type designation:

- Series LSG: Base and cover flange in boiler plate RSt 37-2
- Series LSGR: Base flange in stainless steel, Cover flange RSt 37-2
- Series LSGRR: Base and cover flange in stainless steel

### Ordering example:

- 1 piece type LSGRR 10-3, 1.4571 / SL - PTFE - 8903 - C4400 -1.4301 - A2.

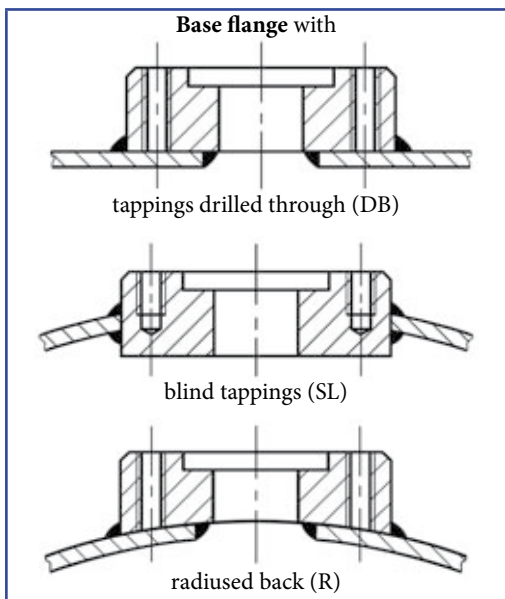

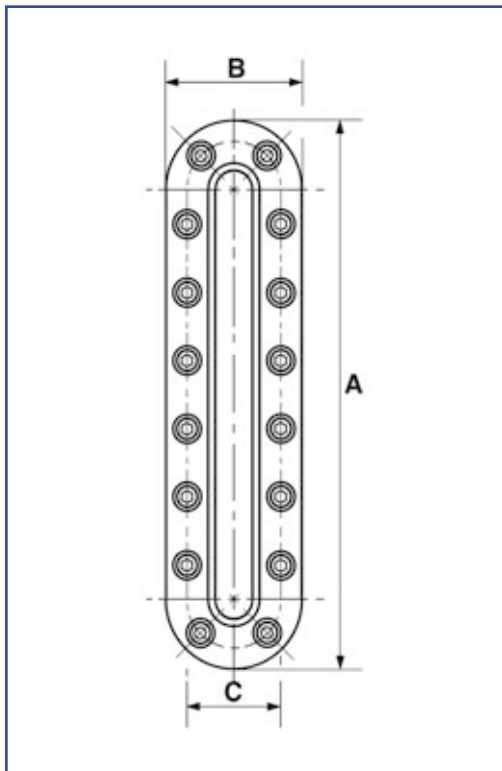
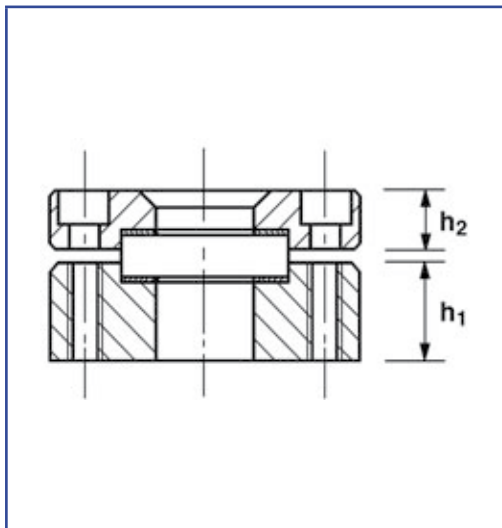

Type LSG LSGR LSGRR	Nominal pressure	Dimension		Free view		Screws M10		Glass plate dimensions	Thickness of flanges		Weight (kg)
		A	B	length	width	No.	C		h1	h2	
2,5-1	2,5	266	116	200	50	8	94	70/10 x 220	25	15	6,3
2,5-2	2,5	341	116	275	50	10	94	70/10 x 295	25	15	7,6
2,5-3	2,5	416	116	350	50	12	94	70/10 x 370	25	15	9,8
2,5-4	2,5	491	116	425	50	14	94	70/10 x 445	25	15	11,0
2,5-5	2,5	566	116	500	50	16	94	70/10 x 520	25	15	12,3
2,5-6	2,5	641	116	575	50	18	94	70/10 x 595	25	15	14,2
2,5-8	2,5	791	116	725	50	22	94	70/10 x 745	25	15	18,0

6-1	6	261	96	195	30	10	74	50/10 x 215	25	15	5,6
6-2	6	316	96	250	30	12	74	50/10 x 270	25	15	7,0
6-3	6	371	96	305	30	14	74	50/10 x 325	25	15	8,0
6-4	6	426	96	360	30	16	74	50/10 x 380	25	15	8,9
6-5	6	481	96	415	30	18	74	50/10 x 435	25	15	10,0
6-6	6	536	96	470	30	20	74	50/10 x 490	25	15	12,0
6-8	6	646	96	580	30	24	74	50/10 x 600	25	15	13,7

10-1	10	260	80	198	18	12	58	35/10 x 215	25	15	5,0
10-2	10	305	80	243	18	14	58	35/10 x 260	25	15	5,8
10-3	10	350	80	288	18	16	58	35/10 x 305	25	15	6,5
10-4	10	385	80	333	18	18	58	35/10 x 350	25	15	7,5
10-5	10	440	80	378	18	20	58	35/10 x 395	25	15	8,0
10-6	10	485	80	423	18	22	58	35/10 x 440	25	15	9,5
10-8	10	575	80	513	18	26	58	35/10 x 530	25	15	13,0

25-1	25	186	80	121	15	10	58	34/17 x 140	25	20	4,0
25-2	25	211	80	146	15	10	58	34/17 x 165	25	20	4,5
25-3	25	236	80	171	15	12	58	34/17 x 190	25	20	5,0
25-4	25	296	80	231	15	14	58	34/17 x 250	25	20	6,0
25-5	25	326	80	261	15	16	58	34/17 x 280	25	20	6,8
25-6	25	366	80	301	15	18	58	34/17 x 320	25	15	7,5
25-8	25	386	80	321	51	18	58	34/17 x 340	25	15	8,0

1) All dimensions in mm.

2) Subject to changes without preliminary notice.