



Spraying units type: SVS

Spraying units for circular sightglasses to DIN 28120 or similar



Spraying unit of the series SVS

Application:

- VETROLUX® spraying units of the series SVS may be used for cleaning the inner face of sightglass discs via an intermittent, continuous or automatically controlled spray. They are suitable in either safe or hazardous areas for all standard sightglasses and may be used both for pressure and vacuum vessels subject to test certification. According to your needs, we recommend the mounting of several units into the same sightglass.

Mounting:

- The mounting is made by means of a connection piece screwed into the welding flange to form a pressure tight seal and through a clearance hole in the cover flange.

Operating conditions:

- These correspond to those of the sightglass used and it's rating.

Materials:

- Contact parts: Stainless steel
- Gasket: PTFE

Possible combinations:

- The spraying units may be used in conjunction with VETROLUX® wipers of the series W / WD or WS together with the lightfittings of the series CHEMLUX®, EdelLUX®, fibroLUX®, miniLUX® or metaLUX® without any restriction.

Connection:

- The connection is made via a hole drilled into the welding flange, M14 x 1,5. A clearance hole of $\varnothing 21$ mm in the cover flange is also required.

Remarks:

- Dependent on operating conditions, a suitable non-return valve should be built into the feed tube.
- When the spraying units are ordered complete with sightglasses, all the necessary fitting requirements will be carried out at our works, as part of the delivery.

Mounting and delivery contents:

- The drawing left shows the elements of the delivery:
 1. Connection piece
 2. Gaskets
 3. Counter nut
 4. Spraying head

Ordering example:

- A spraying unit for mounting into a sightglass to DIN 28120, DN 125: 1 piece SVS.

Important:

- When the spraying unit is to be ordered together with a sightglass unit, we need the following information at the point of order:
 - 1) Nominal diameter (DN), 2) nominal pressure (PN) of the sightglass, 3) materials for the welding and the cover flanges, 4) materials for the product and cover side gaskets, 5) quality of the glass disc (borosilicate / sodium silicate) and 6) material for the studs and nuts.

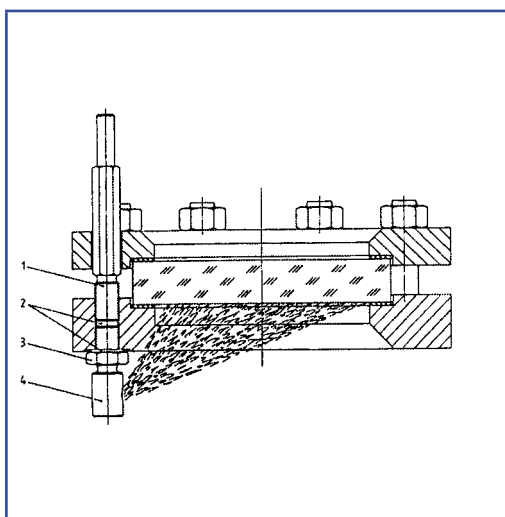

Spraying unit of the series SVS built into circular sightglass to DIN 28120

1) All dimensions in mm.

2) Subject to changes without preliminary notice.