



## Spraying units type: SV

Spraying units for circular sight-glasses to DIN 28120 or similar.



Spraying unit, type SV 4, built into circular sightglass similar to DIN 28120, DN 125, PN 6.

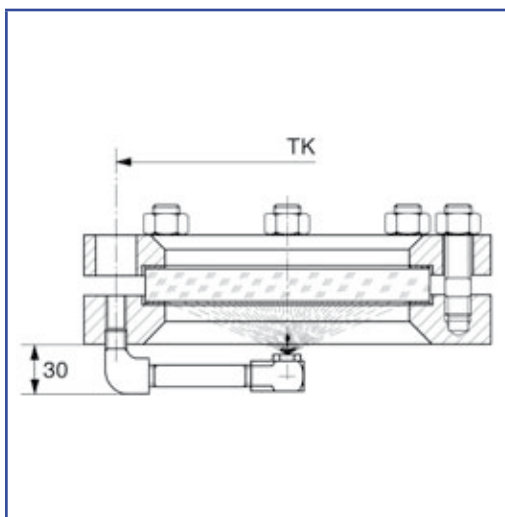

Spraying unit, built into circular sightglass to DIN 28120.

### Application:

• VETROLUX® spraying units of the series SV may be used for cleaning the inner face of sightglass discs via an intermittent, continuous or automatically controlled spray. They are suitable in either safe or hazardous areas for all standard sightglasses and may be used both for pressure and vacuum vessels subject to test certification.

### Mounting:

• The mounting is made by means of a connection piece screwed into the welding flange to form a pressure tight seal and through a clearance hole in the cover flange.

### Operating conditions:

• These correspond to those of the sightglass used and it's rating.

### Materials:

- Contact parts: Stainless steel
- Gaskets: PTFE

### Possible combinations:

• The spraying units may be used in conjunction with VETROLUX® wipers of the series W / WD or WS together with the lightfittings of the series CHEMLUX®, EdelLUX®, fibroLUX®, miniLUX® or metaLUX® without any restriction.

### Delivery contents:

• The complete set consists of a connecting angle piece, a distance tube and the spraying jet head (see drawing left).

### Connection:

• The connection is made via a hole drilled into the welding flange, G1/ 4". A clearance hole of  $\varnothing$  25 mm in the cover flange is also required.

### Remarks:

- Dependent on operating conditions, a suitable non-return valve should be built into the feed tube.
- When the spraying units are ordered complete with sightglasses, all the necessary fitting requirements will be carried out at our works, as part of the delivery.

Type	SV1	SV2	SV3	SV4	SV5	SV6
Nominal diameter (DN) to DIN 28120	50	80	100	125	150	200
Pitch circle TK for connection drillings (mm)	132	160	186	210	240	295

### Ordering example:

• A spraying unit for mounting into a sightglass to DIN 28120, DN 150: 1 piece SV 5.

### Important:

• When the spraying unit is to be ordered together with a sightglass unit, we need the following information at the point of order:

- 1) Nominal diameter (DN), 2) nominal pressure (PN) of the sightglass, 3) materials for the welding and the cover flanges, 4) materials for the product and cover side gaskets, 5) quality of the glass disc (borosilicate / sodium silicate) and 6) material for the studs and nuts.

1) All dimensions in mm.

2) Subject to changes without preliminary notice.