



Sightglass light fittings type: EdelEx 5dH/10dH/20dH on metal fused sightglass flanges for sterile processes

Sightglass light fittings from st. steel for use in hazardous areas



Sightglass light fitting type EdelEx STERI-LINE 20 dH, 24 V, 20 W, EEx d IIC T4, Ex II 2 G + D, on metal fused sightglass flange

Application:

On metal fused sightglass flanges for mounting onto:

- base flanges to DIN 28117 or similar
- weldnecks with flat face
- for the optimal illumination of small and pilot reactors as well as vessels for sterile and aseptic applications, mainly in the pharmaceutical, biotechnological, cosmetic and food processing industries.

IMPORTANT: Only for use with parallel flat face flanges without seal recess. We recommend the use of Belleville spring washers, 2 pcs. for each connection hole.

Advantages:

- Brilliant and glare free illumination
- Extremely small dimensions
- Aseptic
- High security
- Easy installation
- CIP and SIP cleaning possible

Light fitting series EdelEx STERI-LINE (for use in hazardous areas):

- Supply: AC or DC (with integrated transformer AC only)
24, 36, 42, 115, 230, 240 V with integrated transformer (5,10W)
12, 24 V without integrated transformer (20 W)
- Power: 5, 10, 20 W
- Housing: Stainless steel
- Protection mode: IP 65, dust and spray water tight to EN 60529 / DIN VDE 0470 part 1
- Ignition protection type: EEx d
- Explosion group: IIC
- Temperature classes: T4 (10 and 20 W), T6 (5 W)
- ATEX: Ex II 2 G+D, T130 °C (T80 °C in version T6)

For more technical details see data sheet EdelEx 5 dH / 10 dH / 20 dH Metal fused sightglass flange:

- TÜV-approval to the pressure vessel guideline as part of a pressure vessel (for material duplex stainless steel 1.4462)

Technical data:

- Test base: DGRL 97 / 23 / EG, AD 2000 standards, DIN 7079-1 May 1999
- Materials to VdTÜV specifications and the respective DIN/EN standards
- Glass quality: Borosilicate glass to DIN 7080

Material certificates:

- Certificate of conformity to EN 10204-3.1

Operating conditions:

- Pressure: -1 to 16 bar
- Temperatures:
Ring materials: 1.4462 -30 °C až +280 °C
2.4602 -60 °C až +300 °C
2.4605 -60 °C až +300 °C
2.4610 -60 °C až +300 °C

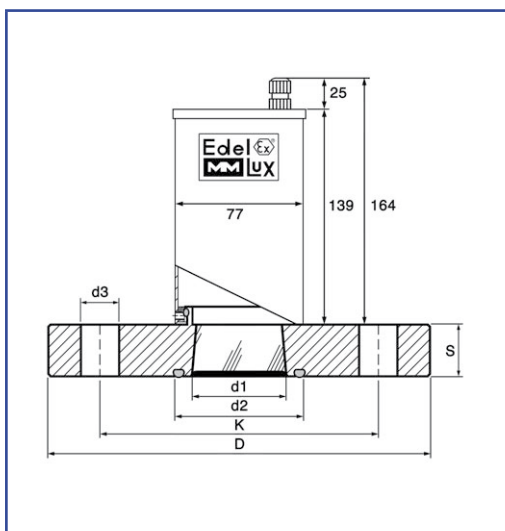

Dimensions with mounted sightglass light fitting

Dimensions:

DN	PN	D	K	S	d1	d2	d3	No. of holes	O-Ring*	Spring washer*
50	16	165	125	21	38	66	18	4	58,74x3,53	31,5/16,3x1,25
65	16	185	145	23	38	86	18	4	78,97x3,53	31,5/16,3x1,25

* Not contained in our delivery

1) All dimensions in mm.

2) Subject to changes without preliminary notice.