



CHEM MM LUX[®]

Sightglass light fittings type: KEL / LKEL / FKEL FLKEL / KL

The ideal solution for your lighting problems
in hazardous as well as safe areas

- Fully developed package
- Various mounting options
- Highly competitive prices
- For combination of sight / light unit as well as for separate fitting (2 port version)
- Also supplied complete with VETROLUX[®] sightglasses

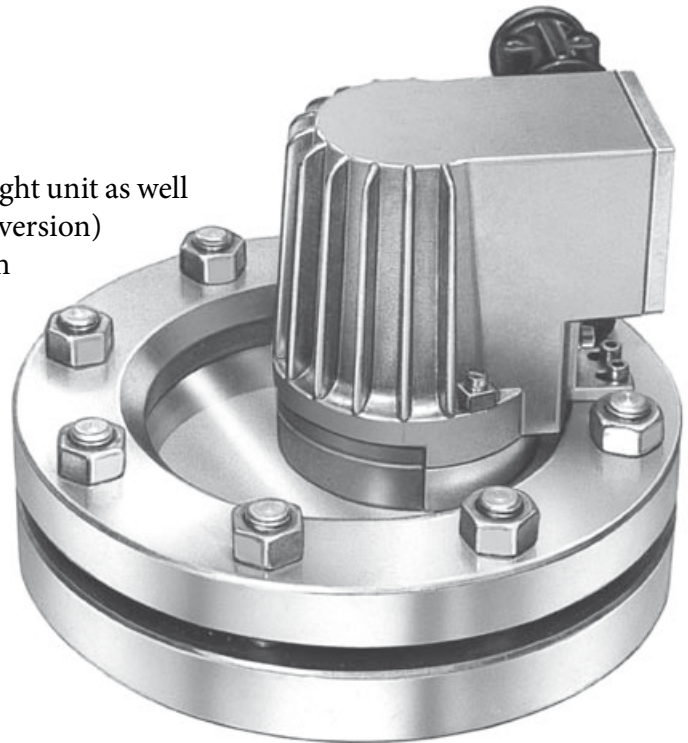

Type KEL 20 deH W, EEx de IIC T4, Ex II 2 G + D, 230 V, 20 W, mounted on circular sightglass to DIN 28120, DN 125, PN 10, in 1 port version.

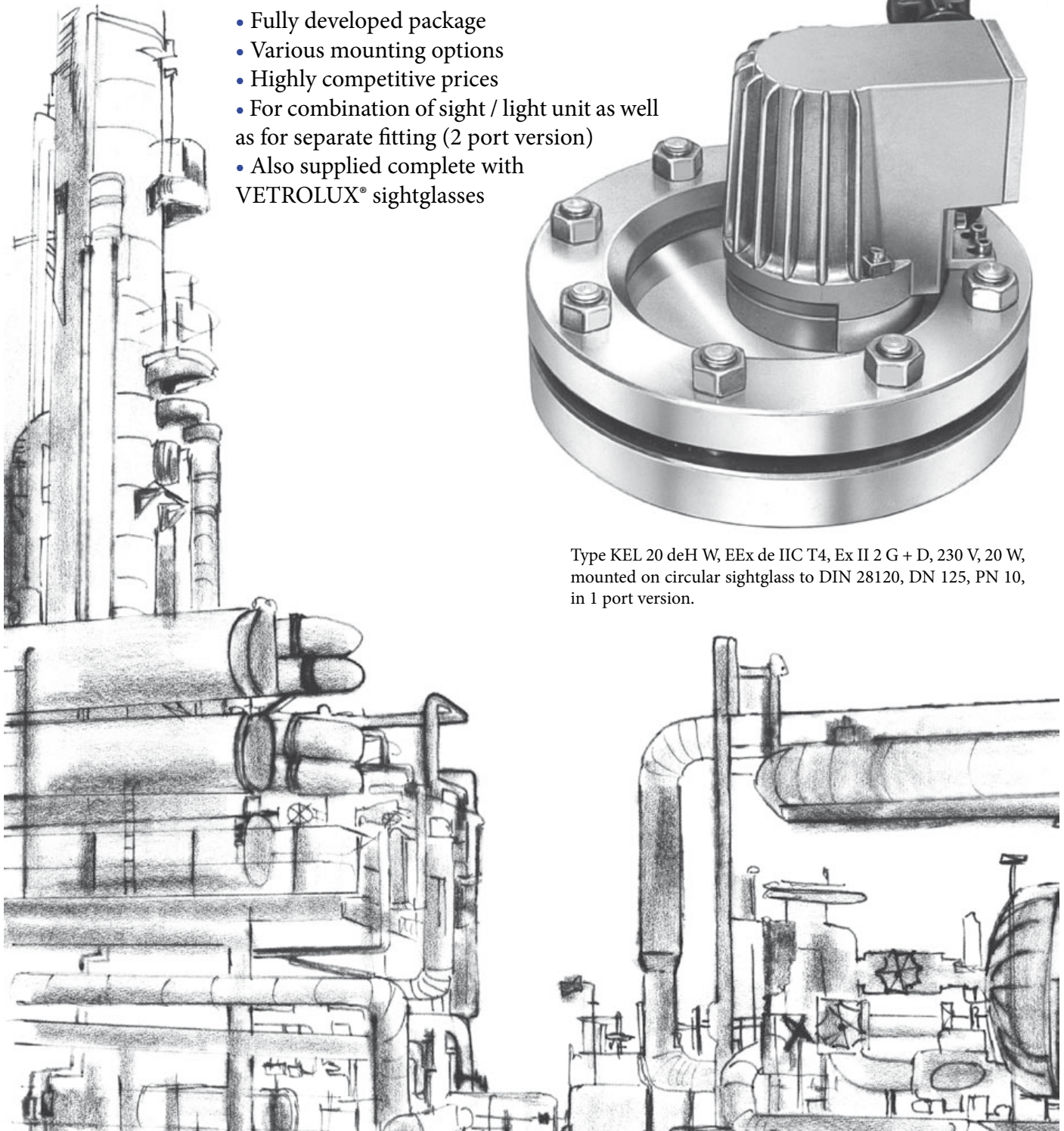



With the series KEL / LKEL / FKEL / FLKEL / KL, you may choose between 19 standard types to meet your own application needs, offering the following principal advantages:

For the purchasing department:

- **Highly competitive prices** due to extremely compact value-engineered design and highly efficient manufacturing techniques
- **Short** lead times

For the design engineer or the plant engineer:

- Versatile design enabling the light fittings to be used as a combination “view and light through one assembly” as well as for use as a separate light fitting in a two port system, already from DN 25 on depending on the type of the sightglass
- Easy installation due to the availability of 3 different fixing systems (side feet “Sch”, fixation bracket “W”, flange collar “R”), meeting all applications on:
 - Circular sightglasses to DIN 28120 / 28121 or similar
 - Screwed sightglasses similar to DIN 11851
 - Sight flow indicators
- **Most compact** design providing brilliant illumination due to high wattage capability up to 100 Watts!
- Hazardous area types with or without connection box. (Ex «de» or Ex «d»)
- Dazzle free illumination due to a wide range of power supplies (refer to page 3) as well as through anti-dazzle shield “B” or opal glass “M”.
- Light units may be installed in any position without restriction.
- Admitted for food processing applications.
- Particularly designed for extremely brilliant lighting of vessels, reactors, tanks or silos.
- Different types may be equipped with an electronic timer “U” or “V” or with a built-in push-button for momentaneous operation (“D”) (see “Additional equipment”, page 3).
- The light fittings for use in hazardous areas are certified to ATEX in the groups G (zones 1 and 2) and D (zones 21 and 22).
- Safe area models may be equipped with a built-in “ON-OFF”-switch (“E”).
- All models may be equipped with transport handle (“T”) thus serving as a hand lamp.

For the maintenance electrician:

- Connection to different supply voltages possible (see following pages).
- Easy replacement of bulbs.
- Halogen bulbs are industry standards available from local suppliers

Operating conditions:

- Completely independent of vessel internal pressure or vacuum. However models with a built-in timer (“U” or “V”) or “ON-OFF” switch (“E”) or push-button (“D”), should be restricted to enclosure temperatures not exceeding 100 °C.

Electrical data:

- Supply: Alternative or direct current (AC or DC), depending on type of the light fitting. (Versions with integrated transformer AC only)
- Terminal voltages: Refer to table on following page for details
- Power: Refer to table on following page for details

Enclosure protection degree:

- IP 65, dust and spray water tight

Construction and material:

- Housing of corrosion resistant cast aluminium alloy (Anticorodal). Upon request painted with a two component acryl based colour (“K”). Cable gland M 20 x 1,5 ((Ex)-types), Pg 11 (safe area types) contained in our delivery. Hazardous area models without junction box are supplied depending on type with standard 5 metre cable length connected internally at our works. (Other cable lengths may be ordered). Connection to terminals up to 2.5 mm². Additional earth terminal 4 mm² external to the housing for hazardous area types. When timer “U” or “V” is included, an operating time of 3 minutes is preprogrammed at our factory. Other operating times may be specified on ordering. With built-in transformers, the hazardous area models contain an integrated fuse. Built-in reflector or reflector-bulb-unit, according to your needs to produce a wide (“flood” version) or concentrated (“spot” version) beam of light. Standard version: “Spot”.

Mounting:

- **On circular sightglasses to DIN 28120 or similar:**
 - DN 25 - DN 150: With side feet ... “Sch”
 - DN 80 - DN 200: With fixation bracket ... “W”
- **On circular sightglasses to DIN 28121 or similar:**
 - DN 40 - DN 200: With side feet ... “Sch”
 - DN 80 - DN 200: With fixation bracket ... “W”
- **On screwed sightglasses similar to DIN 11851:**
 - DN 65 - DN 100: With intermediate flange collar “R” in AISI 304 (DN size should be specified on ordering)
 - From DN 125 on: With fixation bracket “W” onto the grooved collar nut
- **On sight flow indicators:**
 - With fixation bracket “W” or specific customer adaptation (i. e. the light housing has 4 drilled holes M5 size for this purpose)



Type designation for	Safe area light fitting	KL5H		KL10H		KL20H				KL50H KL100H
	Hazardous area light	FKEL5dH	KEL5deH	FKEL10dH	KEL10deH	FKEL20dH	KEL20deH	FKEL50dH	KEL50deH	
		FLKEL5dH	LKEL5deH	FLKEL10dH	LKEL10deH	FLKEL20dH	LKEL20deH			
Nominal rating	(W)	5	5	10	10	20	20	50	50	50 100
Terminal voltage with built-in transformer	(V)	24, 36 42, 115 230, 240	24, 36 42, 115 230, 240	24, 36 42, 115 230, 240	24, 36 42, 115 230, 240	24, 36 42, 115 230, 240	24, 36 42, 115 230, 240			
Secondary voltage of built-in transformer	(V)	12	12	12	12	12	12			
Terminal voltage without transformer (AC/DC)	(V)	12	12	12	12	12, 24	12, 24	12, 24	12, 24	12, 24
Bulb		Halogen	Halogen	Halogen	Halogen	Halogen	Halogen	Halogen	Halogen	Halogen
Socket		G4	G4	G4	G4	G4	G4	GY 6.35	GY 6.35	GY 6.35
Lateral junction box			•		•		•		•	
Weight with lateral junction box (kg)	with trans		2,15 ⁽¹⁾ 2,45 ⁽³⁾		2,15 ⁽¹⁾ 2,45 ⁽³⁾		2,15 ⁽¹⁾ 2,45 ⁽³⁾			
	without trans.		1,65 ⁽¹⁾ 1,95 ⁽³⁾		1,65 ⁽¹⁾ 1,95 ⁽³⁾		1,65 ⁽¹⁾ 1,95 ⁽³⁾		1,65	
Weight without lateral junction box (kg)	with trans	2,25 ⁽¹⁾ 2,56 ⁽²⁾		2,25 ⁽¹⁾ 2,56 ⁽²⁾		2,25 ⁽¹⁾ 2,56 ⁽²⁾				
	without trans.	1,75 ⁽¹⁾ 2,06 ⁽²⁾		1,75 ⁽¹⁾ 2,06 ⁽²⁾		1,75 ⁽¹⁾ 2,06 ⁽²⁾		1,25		1,25

The lower indications are only valid for the hazardous area models.

Ignition protection to DIN EN	50014 / 50018	EEx d		EEx d		EEx d		EEx d	
	50014 / 50018 50019		EEx de		EEx de		EEx de		EEx de
Explosion group		IIC	IIC	IIC	IIC	IIC	IIC	IIC	IIC
Temperat. class		T6	T6	T4	T4	T4	T4	T3	T3
ATEX	Ex II 2 G+D	T 80 °C	T 80 °C	T 130 °C	T 130 °C	T 130 °C	T 130 °C	T 195 °C	T 195 °C

* Only light fitting. Fixations "W" 0.03 kg, "Sch" 0.16 kg.

(1) Indicated weights are for hazardous area types (series KEL / FKEL). Safe area models (series KL) 0.5 kg less.

(2) Series FLKEL

(3) Series LKEL



Transport handle ... T

This ergonomic and insulated handle makes transport around the plant easy, and also facilitates the use of the light fitting for inspection inside a vessel on a trailing lead.

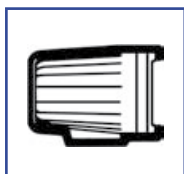

Paint finish ... K

The special two component acrylic paint finish protects against corrosion in excessively aggressive environments, and may satisfy customers special aesthetic requirements. RAL 9001 is standard, other colours on demand.

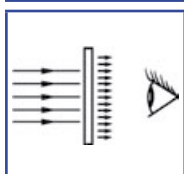

Opal glass ... M

In some cases, such as in pipeline flow indicator applications, a strong blinding effect occurs. For such situations we offer an opalised glass fitted into the unit, which increases the dispersion of the light and eliminates glare.

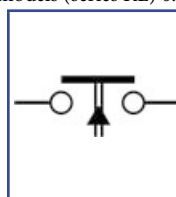

Device for momentary operation ... D

In order to cut down on wasted energy and improve the bulb life, the safe area light fittings and the series LKEL / FLKEL may be equipped with a built-in device providing momentary illumination. This device cannot be combined with timers "V" or "U". (Please refer to our leaflet "switches, push-buttons and timers").

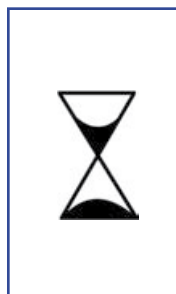

Timers ... V / U

The timers for operation on the unit or at a distance ...V or at distance only ...U save energy and increase the lifetime of the bulb by limiting operation to approximately 3 minutes. They are particularly recommended for short or sporadic observation of the vessel contents. The timers cannot be combined with the device ...D.

Timer U: For types (F)KEL 5 / 10 dH / deH with 12 V and (F)KEL 20 dH / deH with 12 or 24 V supply voltage as well as for series LKEL / FLKEL

Timer V: For series LKEL / FLKEL

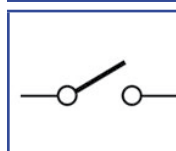

ON-OFF-switch ... E

This switch is available for the types KL 20 H in all supply voltages, for the type KL 50 H with 12 or 24 V supply and for the type KL 100 H with 24 V supply. (Please refer to our leaflet "switches, push-buttons and timers").



Safe area type KL 100 H Sch B, 24 V, 100 W, with anti-dazzle shield "B", on circular sightglass to DIN 28120, DN 150, PN 10, in version "view and light through one sightglass".

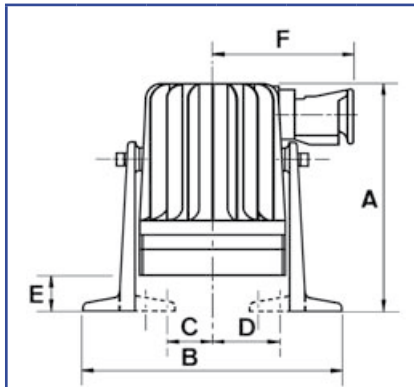

A	B	C	D	E	F
157	178	30	45	24	104

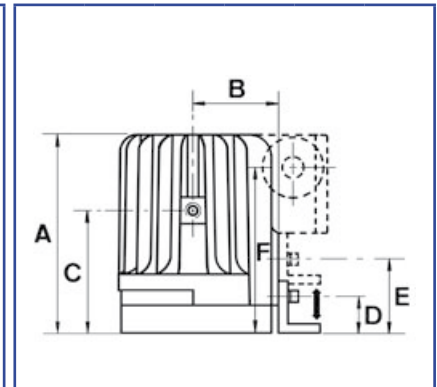

A	B	C	D	E	F
133	56	81	28	44	111

* Series LKEL / FLKEL: + 31 mm



Hazardous area type FKEL 20 dH R, EEx d IIC T4, Ex II 2 G + D, 230 V, 20 W, on screwed sightglass similar to DIN 11851, DN 65, PN 6. Fixation with intermediate flange collar "R".

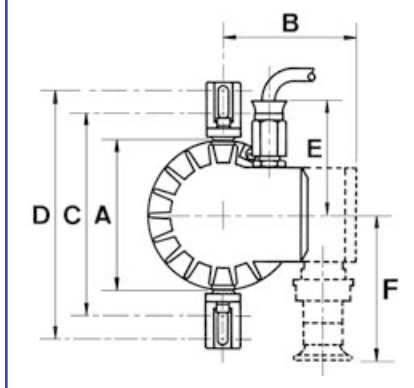

A	B	C	D	E	F
100	88	136	164	76	104

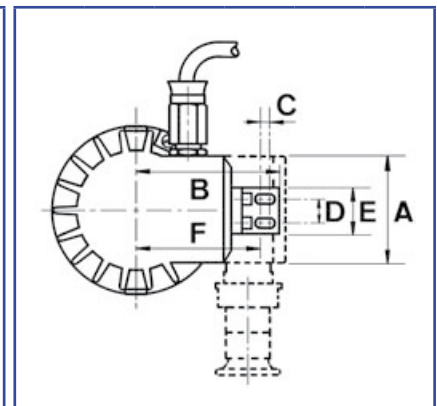

A	B	C	D	E	F
64	84	5	14	28	73



Hazardous area type FKEL 5 dH WM, EEx d IIC T6, Ex II 2 G + D, 230 V, 5 W, with opal glass "M", on pipeline flow indicator DN 50.

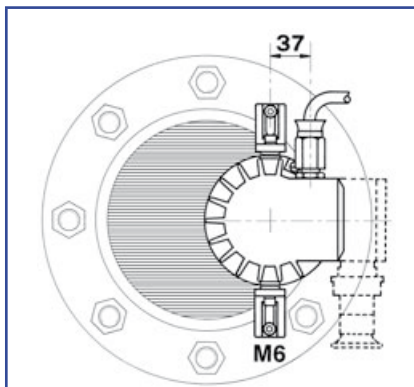

Fixation "Sch"

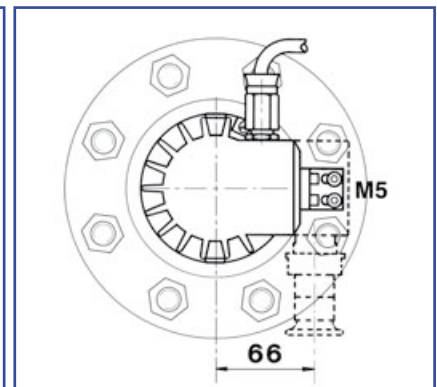

Fixation "W"

Do you wish for more information about our wide range of light fittings for use in hazardous or safe areas, about our range of circular sightglasses to DIN 28120/28121, screwed sightglasses similar to DIN 11851, rectangular or D-ended sightglasses, pipeline flow indicators, sideways or centrally operated wipers, hinged sightglasses, spraying devices or our complete sight and lightglass units VETROLUX®? Are you interested in other types, special versions or different protection degrees? If yes, please contact us – it is our business! You will find the necessary indications about our company on the Internet.

1) All dimensions in mm.
2) Subject to changes without preliminary notice.