

## SIGHT GLASSES, LIGHT FITTINGS



### LED sightglass light fittings type: KEL / FKEL / KL PowerLED

LED sightglass light fittings for use in hazardous and safe areas

The series KEL / FKEL / KL PowerLED offer – in addition to a to date unknown illumination power – the following key advantages:

#### For the purchasing department:

- **Highly competitive prices** due to value-engineered design and efficient manufacturing
- **Short lead times** due to large stock

#### For the design or plant engineer:

- **Supreme efficiency:** Light output of ~980 Lumen with power consumption of only 7 W
- **Super-compact design** providing for **brilliant illumination**
- LED light source with **life span of up to 40'000 operating hours**
- **UV-free and cold light** output
- Versatile design enabling the light fittings to be used as a combination “view and light through one assembly” as well as for use as a separate light fitting in a two port system, already from DN 25 depending on the type of the sightglass
- **Easy installation** due to 3 different fixation systems (side feet “Sch”, fixation bracket “W”, flange collar “R”) on:
  - Circular sightglasses to DIN 28120 / 28121 or similar
  - Screwed sightglasses similar to DIN 11851
- Light fittings may be **installed in any position without restriction**
- ATEX equipment protection level (EPL): Gb (zones 1 and 2) and Db (zones 21 and 22)

#### Operating conditions:

Completely **independent** of internal vessel pressure and vacuum.

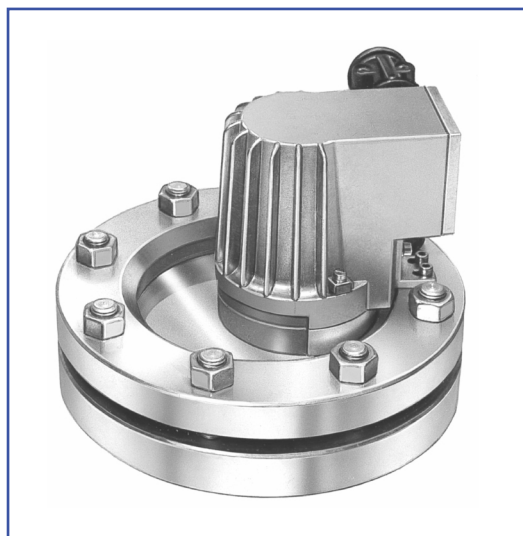

Hazardous area type KEL de PowerLED W, Ex de op is IIC T6 Gb, Ex tb IIIC T80°C Db, IP65/67, Ex II 2 G + D, 230-240 V AC, 7 W, mounted on circular sightglass to DIN 28120, DN 125, PN 10, in 1 port version.

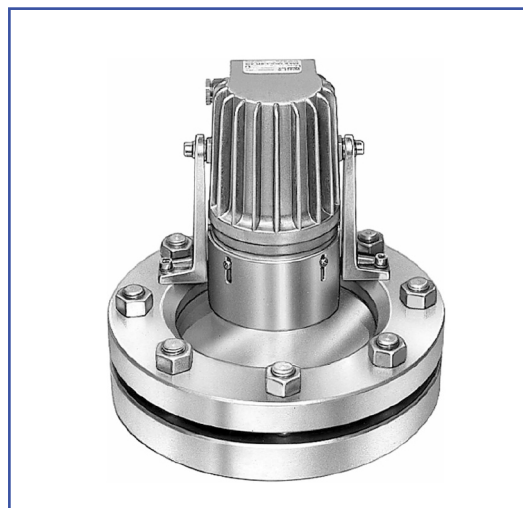

Safe area type KL PowerLED Sch B, 24 V AC / DC, 7 W, with anti-dazzle shield “B”, on circular sightglass to DIN 28120, DN 150, PN 10, in version “view and light through one sightglass”.

Type designation	Safe area light fitting	Hazardous area light fittings	
	KL PowerLED	KEL de PowerLED	FKEL d PowerLED
Nominal rating (W)	7		
Terminal voltage (V)	24 V AC / DC / 230-240 V AC		
Weight (kg)	~1,65	~1,75	~1,65
Lateral junction box	no	yes	no
Ignition protection type		To EN 60079-0 / 60079-1 / 60079-7 / 60079-28 / 60079-31: Ex de op is IIC Gb Ex tb IIIC Db	To EN 60079-0 / 60079-1 / 60079-28 / 60079-31: Ex d op is IIC Gb Ex tb IIIC Db
Explosion groups		IIC / IIIC	
Temperature class G / D (Ta = - 20°C / + 40°C)		T6 / T80 °C	
ATEX		Ex II 2 G + D	

#### Enclosure protection degree:

IP 65 / 67, dust tight and jetwater-proof as well as protected against the effects of temporary immersion to EN 60529 / DIN VDE 0470 part 1.

#### Construction and materials:

Housing, lensholdering, fixation parts and junction box cover (KEL de PowerLED only) of corrosion resistant cast aluminium alloy (Anticorodal). Connection to terminals up to 2.5 mm<sup>2</sup>. Additional earth terminal 4 mm<sup>2</sup> external to the housing (KEL de / FKEL d PowerLED only). Built-in LED module, with wide (“flood” version) or concentrated (“spot” version) beam of light, depending on your needs. Standard version: “Spot”.

# SIGHT GLASSES, LIGHT FITTINGS

## Options:

- **Anti-dazzle shield "B"** or **opal glass "M"** for a dazzle free illumination
- **Paint finish "K"** of the housing with two component acrylic color for increased protection against atmospheric exposure in case of outdoor use or against corrosion in excessively aggressive environments. RAL 9001 is standard, other colours on demand.
- **External timers** for timed operation

## Mounting:

- On circular sightglasses to DIN 28120 or similar:  
DN 25 – DN 150: With side feet "Sch"  
DN 80 – DN 200: With fixation bracket "W"

- On circular sightglasses to DIN 28121 or similar:  
DN 40 – DN 200: With side feet "Sch"  
DN 80 – DN 200: With fixation bracket "W"

- On screwed sightglasses similar to DIN 11851:  
DN 50 – DN 100: With intermediate flange collar "R" in 1.4301 (= AISI 304) (order should specify the DN size)

From DN 125 on: With fixation bracket "W" onto the grooved collar nut

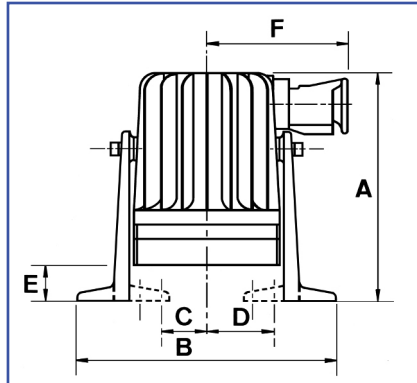

A	B	C	D	E	F
157	178	30	45	25	104

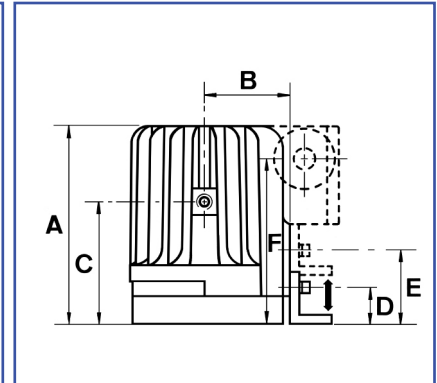

A	B	C	D	E	F
133	56	81	28	44	111

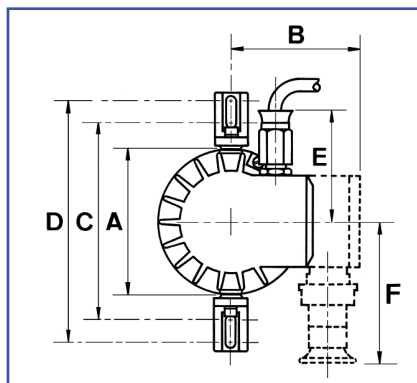

A	B	C	D	E	F
100	88	136	164	76	104

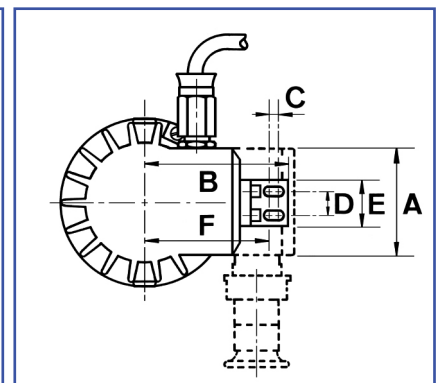

A	B	C	D	E	F
64	84	5	14	28	73

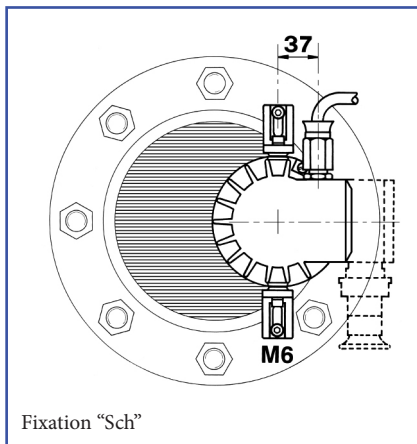

Fixation "Sch"

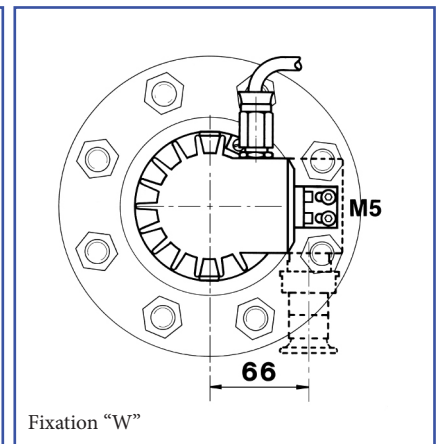

Fixation "W"

Hazardous area type FKEL d PowerLED R65, Ex d op is IIC T6 Gb, Ex tb IIIC T80°C Db, Ex II 2 G + D, IP 65/67, 230–240 V AC, 7 W, on screwed sightglass similar to DIN 11851, DN 65, PN 6. Fixation with intermediate flange collar "R".

Do you wish for more information about our wide range of light fittings for use in hazardous and safe areas, about our range of circular sightglasses to DIN 28120/28121, screwed sightglasses similar to DIN 11851, rectangular or D-ended sightglasses, pipeline flow indicators, hinged sightglasses with or without illumination, centrally or sideways operated wipers, spraying devices, camera systems for hazardous areas or our complete sight and lightglass units VETRO-LUX®? Are you interested in other types, special versions or different protection degrees? If yes, please contact us, our branch office or our local agents – it is our business! You will find the necessary information on our sales network on the Internet.